

Installation Guide

Heat Cartridge Kit ICAD 600 / ICAD 900 for ICM

027R9788

027R9788

Technical data

Danfoss recommends the installation of the Heat Cartridge Kit ICAD 600 / ICAD 900 on ICM motor operated valves in the following applications:

When the media temperature through the ICM valve is lower than -30°C (-22°F).

When the ICM valve is installed outdoor and the media temperature through the ICM valve is lower than -10°C (14°F).

When the ICM is installed indoor, with relative humidity higher than 90%, and when the media temperature through the ICM valve is lower than -10°C (14°F).

Voltage

24 V d.c / 24 V a.c

Load

1.5 A / 30 W

Cable

The Heat Cartridge is delivered with 1 m (39 in.) cable.

$3 \times 0.5 \text{ mm}^2$ ($3 \times \sim 20 \text{ AWG}$).

- Brown and Blue: 24 V d.c (polarity unimportant), 24 V a.c
- Yellow/Green: Ground/Earth

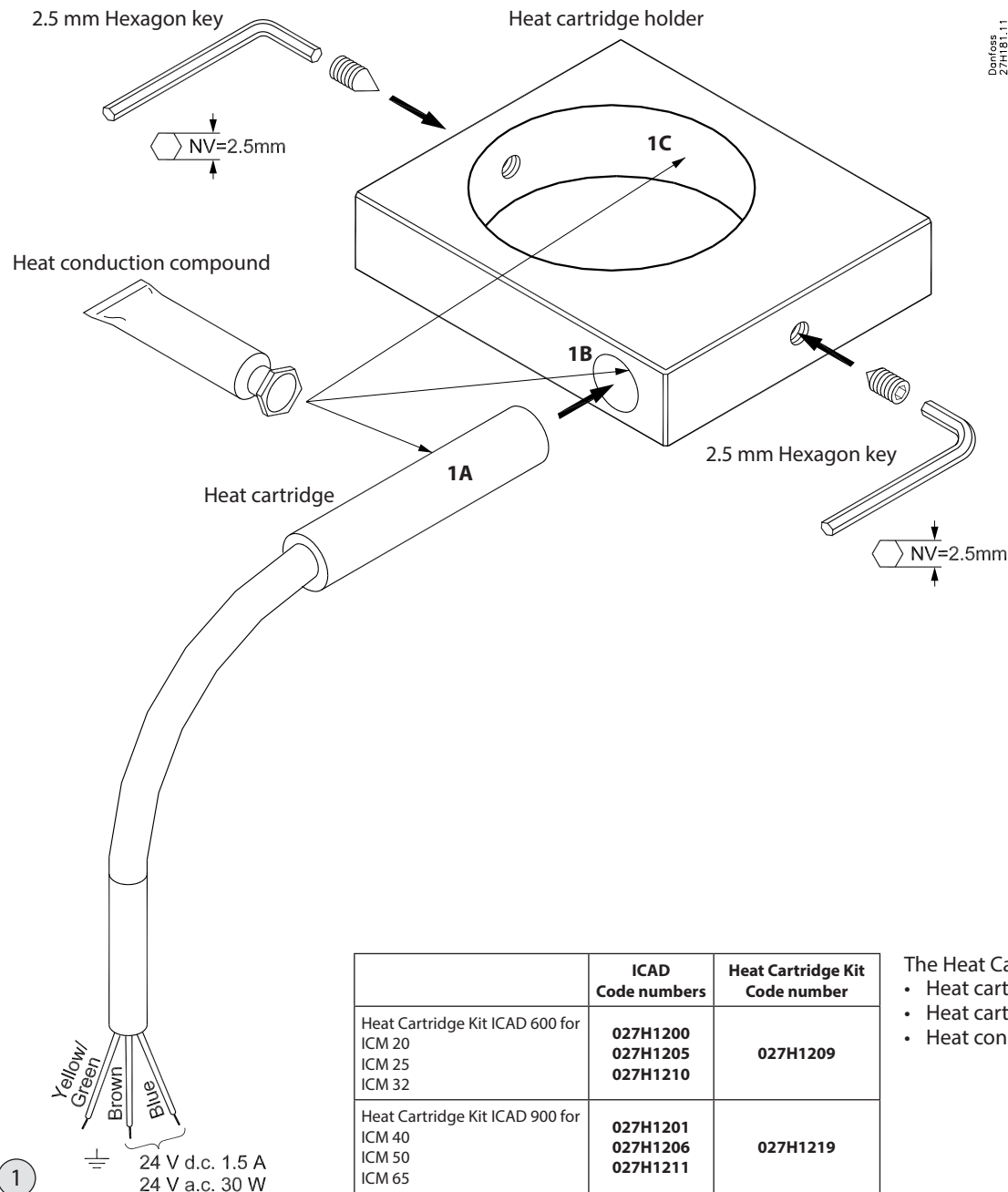

The Heat Cartridge Kit contains:

- Heat cartridge
- Heat cartridge holder
- Heat conduction compound

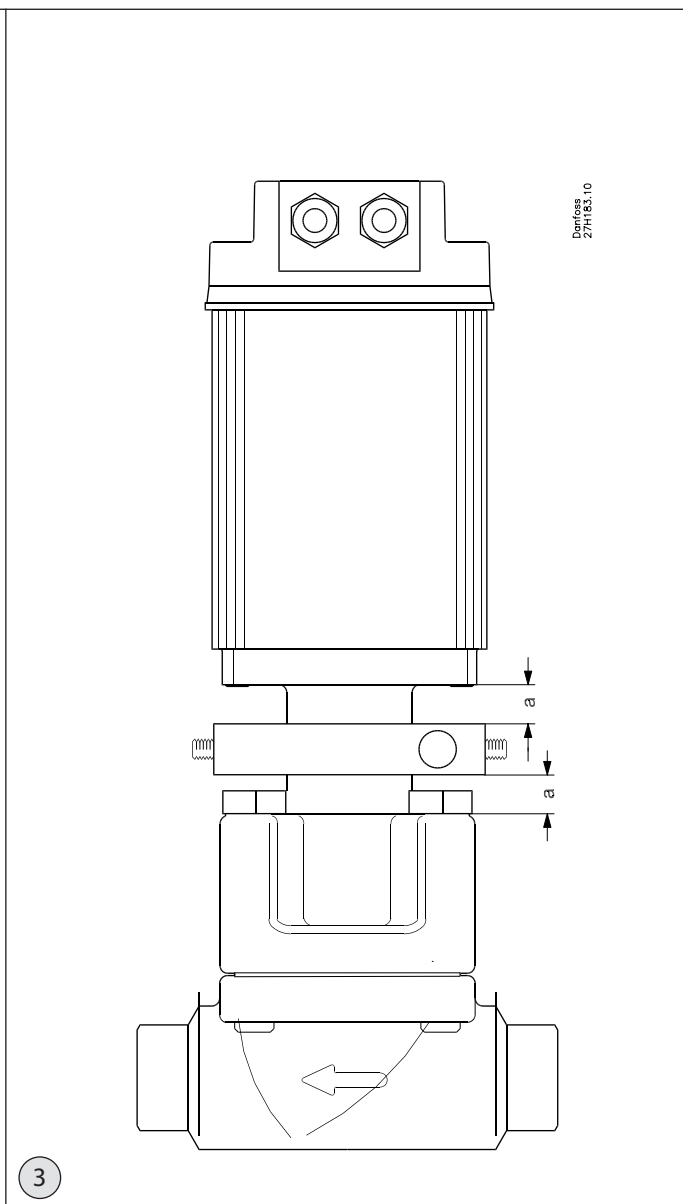
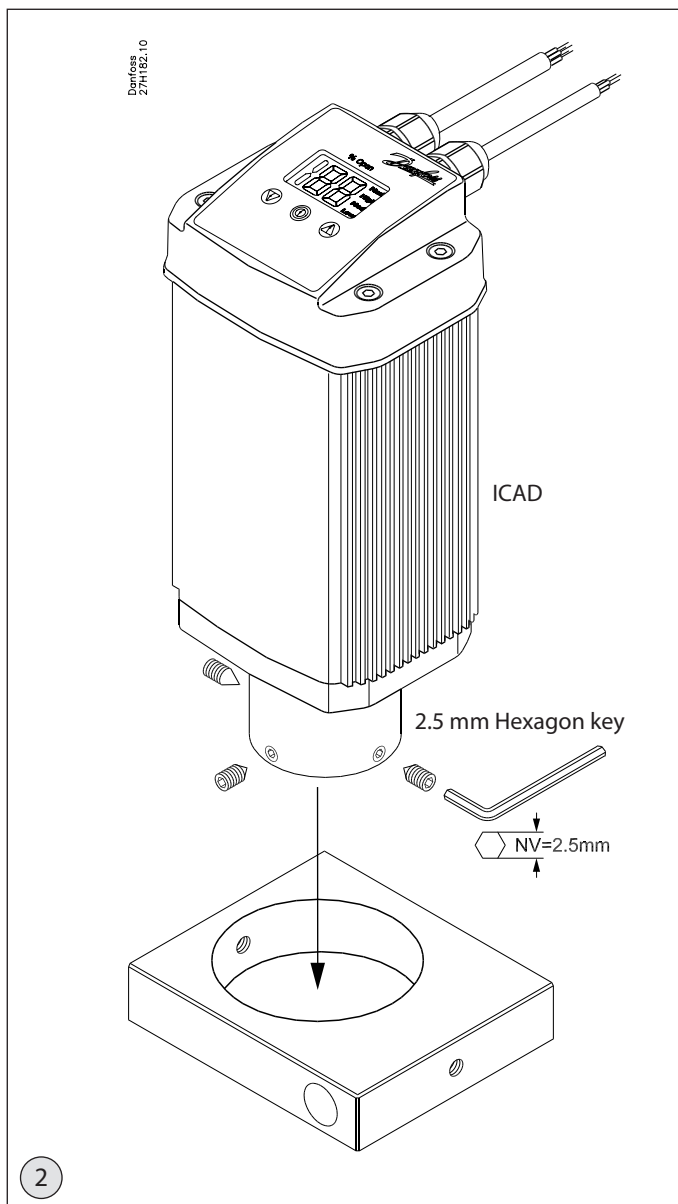

Installation

Mechanical installation

General procedure for installing the Heat Cartridge Kit ICAD 600 / ICAD 900 on all sizes of ICM valves:

Please Note:

The Heat Cartridge Kit ICAD 600 / ICAD 900 must be installed before the ICAD 600/900 actuator is mounted on the ICM valve.

- Check that the three socket set screws on the ICAD actuator are counter clockwise fully unscrewed and removed with a 2.5 mm Hexagon key (see fig. 2).
- Check that the two socket set screws on the heat cartridge holder are counter clockwise fully unscrewed with a 2.5 mm Hexagon key (see fig. 1).
- Apply heat conductive compound to:
 - the heat cartridge (marked 1A in fig. 1)
 - into both ends of the holes for heat cartridge, on the heat cartridge holder (marked 1B in fig. 1)
 - on the inner surface of the heat cartridge holder (marked 1C in fig. 1)

- Insert the heat cartridge into the smallest hole of the heat cartridge holder (see fig. 1).
- Fasten the heat cartridge with the socket set screw using a 2.5 mm Hexagon key.
- Insert the ICAD into the hole of the heat cartridge holder. (fig. 2)
- Install the heat cartridge holder on the ICAD actuator. Position the heat cartridge holder in a center position as shown in fig. 3
- Fasten the heat cartridge holder using a 2.5 mm Hexagon key.
- Reinstall the three socket set screws on the ICAD actuator.
- Please consult the ICAD instruction (DKRCI.PI.HV0.A) regarding the mounting of ICAD actuators on ICM motor operated valves.

Electrical installation

Please Note:

Do not connect supply voltage before the heat cartridge is inserted into the hole of the the heat cartridge holder - then connect 24 V d.c/a.c