

Data sheet

# Hand operated regulating valves

## Types REG-SA and REG-SB



REG-SA and REG-SB are angleway and straightway hand operated regulating valves, which act as normal shut-off valves in closed position.

The valves are available in two different versions – REG-SA and REG-SB designed for regulation purposes in liquid and expansion lines.

The valves are designed to meet the strict quality requirements on refrigerating installations specified by the international classification societies and are carefully designed to present favourable flow conditions and accurate linear characteristics.

REG-SA and REG-SB are equipped with vented cap and internal backseating enables replacement of the spindle seal whilst the valve is active, i.e. under pressure.

### Features

- Applicable to HCFC, HFC, R717 (Ammonia), R744 (CO<sub>2</sub>), Propane, Butane, Iso-Butane and Ethane.
- Modular Concept:
  - Each valve housing is available with several different connection types and sizes.
  - Possible to convert REG-SA or REG-SB to any other product in the Flexline™ SVL family (shut-off valve, check & stop valve, check valve or strainer) just by replacing the complete top part.
- Fast and easy valve overhaul service. It is easy to replace the top part and no welding is needed.
- Designed to ensure perfect regulation
- Internal backseating enables replacement of the spindle seal whilst the valve is active, i.e. under pressure.
- Easy to disassemble for inspection and possible repair.
- Long neck versions (DN 15 to DN 40) for insulated systems available from parts programme.
- Max. operating pressure: 52 bar g (754 psi g)
- Temperature range: –60/+150°C (–76/+302°F)
- Acts as a normal shut-off valve in closed position.
- Housing and bonnet material is low temperature steel according to requirements of the Pressure Equipment Directive and other international classification authorities.
- Exact capacity and setting of the valve can be calculated for all refrigerants by means of Coolselector®2 (Danfoss calculation and selection software).
- Classification: DNV, CRN, BV, EAC etc. To get an updated list of certification on the products please contact your local Danfoss Sales Company.

**Design**
**Housing**

Housing is Standard SVA angleway or straightway housing allowing other inserts from the SVL platform to be installed. Material is special, cold resistant steel

**Connections**

Available with the following connections:

- Butt-weld DIN (EN 10220)
  - DN 10 - 65 (3/8 - 2 1/2 in.)
- Butt-weld ANSI (B 36.10 Schedule 80)
  - DN 10 - 40 (3/8 - 1 1/2 in.)
- Butt-weld ANSI (B 36.10 Schedule 40)
  - DN 50 - 65 (2 - 2 1/2 in.)
- Butt-weld GOST, (8734-75 and 8732-78)
  - DN 10 - 65 (3/8 - 2 1/2 in.)
- Socket weld (ANSI B 16.11)
  - DN 15 - 40 (1/2 - 1 1/2 in.)
- FPT inside pipe thread, NPT (ANSI/ASME B 1.20.1)
  - DN 15 - 32 (1/2 - 1 1/4 in.)

**The cone**

The valves are available in two different versions – REG-SA with an A cone and REG-SB with a B cone. The A cone is designed for expansion lines, while the B cone is designed for regulating purposes e.g. liquid lines.

The valve cone is designed to ensure perfect regulation and provide an extensive regulating area. Irrespective of the refrigerant used, it is easy to obtain the correct capacity. A cone seal ring provides perfect sealing at a minimum closing momentum.

The valve cone can be turned on the spindle, thus there will be no friction between the cone and the seat when the valve is opened and closed.

**Spindle**

The spindle is made of polished stainless steel, which is ideal for O-ring sealing.

**Packing gland - REG-SA and REG-SB**

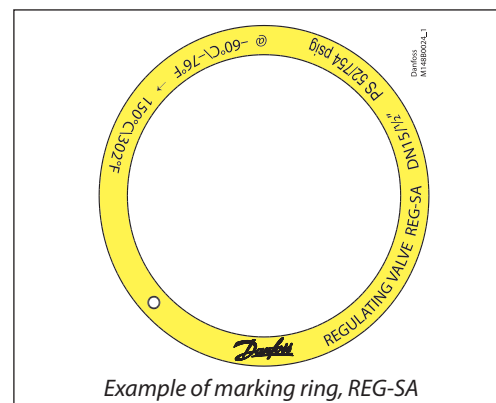
The “full temperature range” packing gland ensures perfect tightness in the whole range: –60/+150°C (–76/+302°F). The packing glands are equipped with a scraper ring to prevent penetration of dirt and ice.

**Installation**

Install the valve with the spindle up or in horizontal position. The flow must be directed towards the cone.

The valve is designed to withstand high internal pressure. However, the piping system in general should be designed to avoid liquid traps and reduce the risk of hydraulic pressure caused by thermal expansion.

For further information refer to product instruction for REG-SA and REG-SB.



Example of marking ring, REG-SA

**Pressure Equipment Directive (PED)**

REG valves are approved according to the European standard specified in the Pressure Equipment Directive and are CE marked.



REG-SA and REG-SB valves			
Nominal bore	DN = < 25 mm (1 in.)	DN32-80 mm (1 1/4 - 3 in.)	DN100 - 125 mm (4 - 5 in.)
Classified for	Fluid group I		
Category	Article 3, paragraph 3	II	III

**Technical data**

- **Refrigerants**  
Applicable to HCFC, HFC, R717 (Ammonia), R744 (CO<sub>2</sub>), Propane, Butane, Iso-Butane and Ethane.
- **Temperature range**  
–60/+150°C (–76/+302°F)
- **Max working pressure**  
52 bar g (754 psi g)
- **Flow coefficients**  
Flow coefficients for fully opened valves from  $k_v = 0.15$  to 80 m<sup>3</sup>/h ( $C_v = 0.17$  to 92.5 USgal/min).

**Computation and selection**

*Introduction*

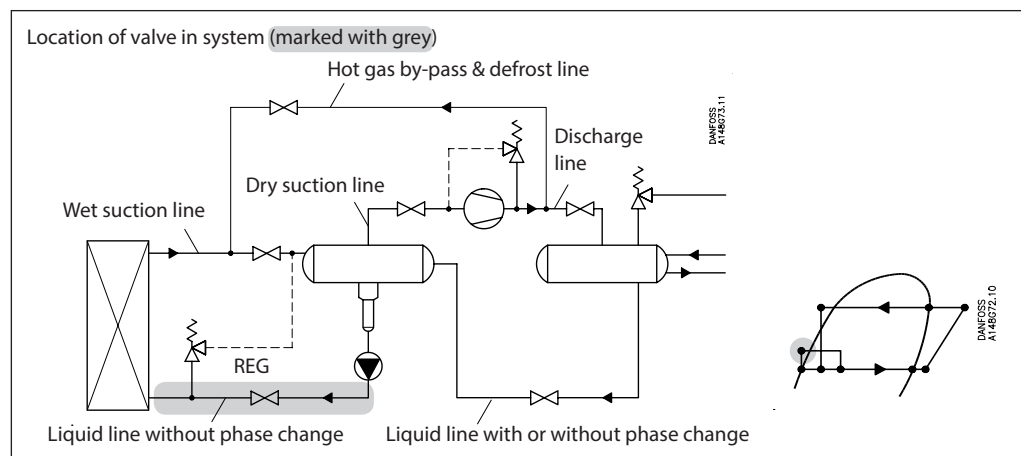
In refrigeration plants, hand operated regulating valves are primarily used in liquid lines in order to regulate the flow of refrigerant. The valves can, however, also be used as expansion valves. From a calculation point of view the two fields of application are very different.

Normal flow is the term used to describe the general case where the flow through the valve is proportional to the square root of the pressure drop across it and inversely proportional to the density of the refrigerant (Bernoullis equation).

This relationship between mass flow, pressure drop and density satisfies the majority of all valve applications with refrigerants and brines.

Normal flow is characterised by turbulent flow through the valve without any phase change. The following capacity curves are based on the above mentioned assumption.

Application of the hand operated regulating valves outside the normal flow area will reduce the capacity of the valve considerably. In such cases it is recommended to use Coolselector®2 (Danfoss calculation and selection software).



*Sizing hand operated regulating valve for liquid flow*

Liquid refrigerants: Use the liquid tables, fig. 6 - 10. For other refrigerants and brines, "Normal flow" (Turbulent flow); see below and use the flow coefficient tables (fig. 1 - 5).

**SI-units**

Mass flow:

$$k_v = \frac{G}{\sqrt{\rho \times 1000 \times \Delta p}} = G \times C_A \text{ [m}^3/\text{h]}$$

Volume flow:

$$k_v = \frac{\dot{V}}{\sqrt{\frac{1000 \times \Delta p}{\rho}}} \text{ [m}^3/\text{h]}$$

**Imperial units**

Mass flow:

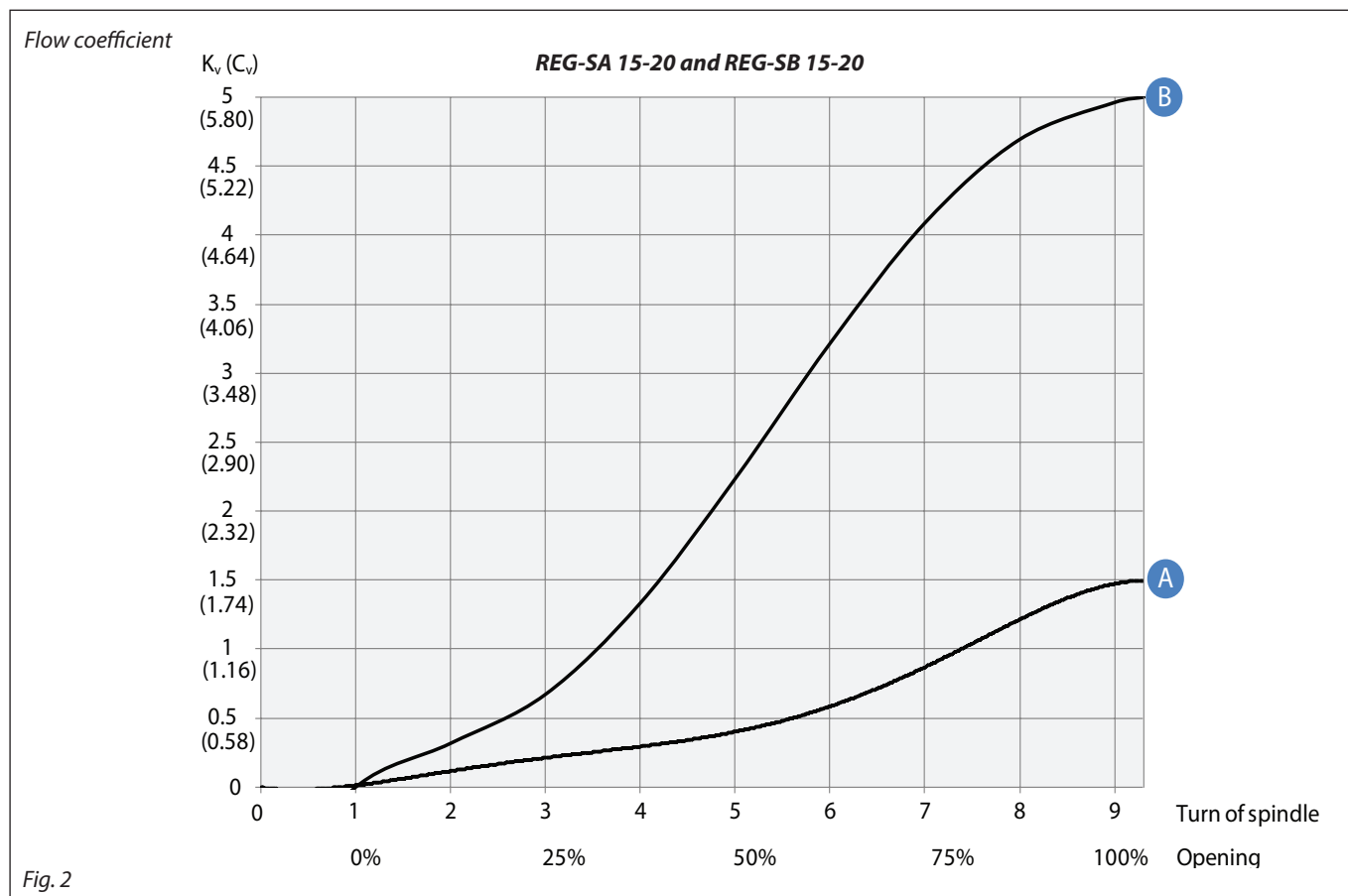
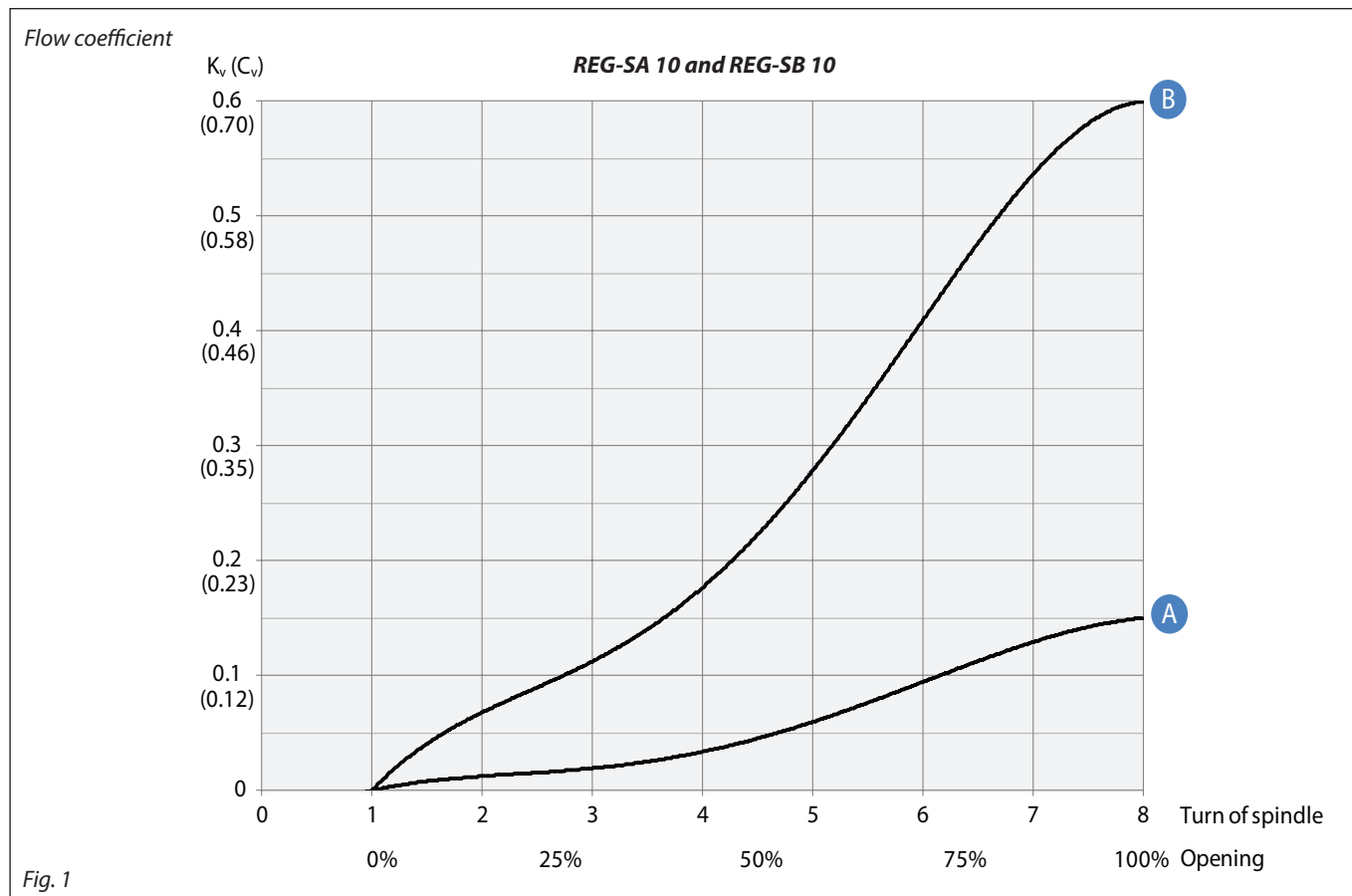
$$C_v = \frac{0.95 \times G}{\sqrt{\rho \times \Delta p}} = 31.6 \times G \times C_A \text{ [USgal/min.]}$$

Volume flow:

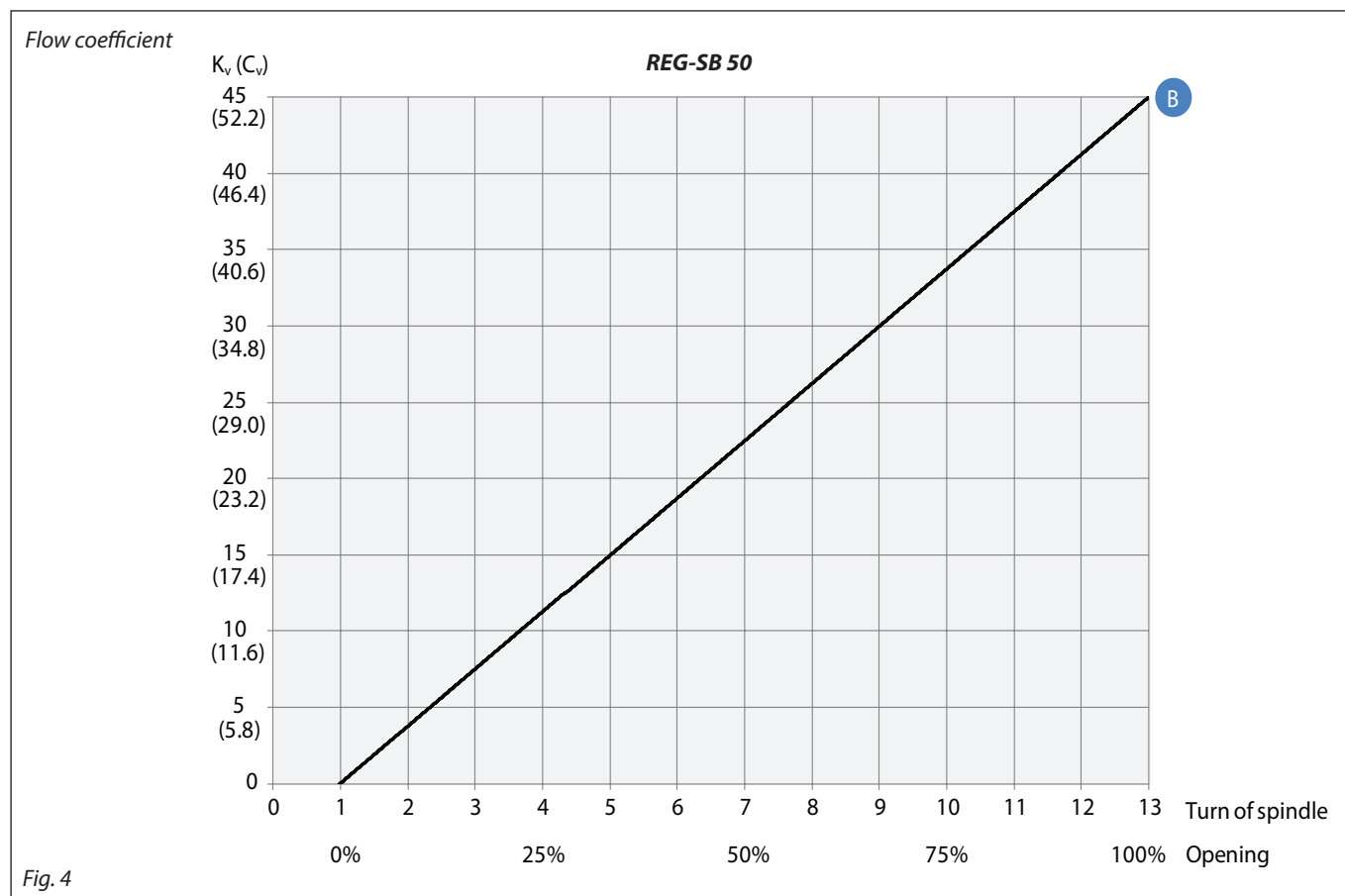
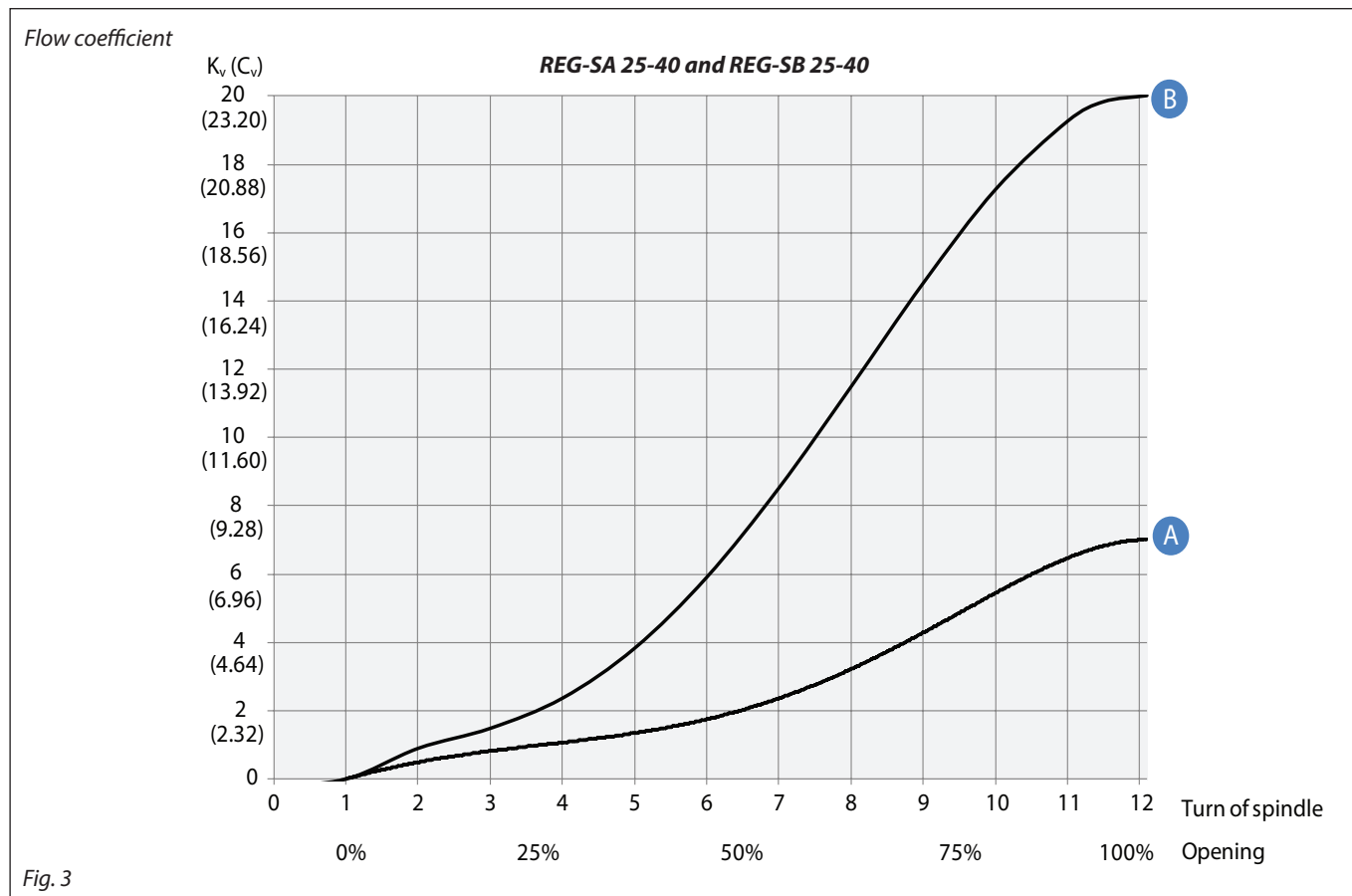
$$C_v = \frac{0.127 \times \dot{V}}{\sqrt{\frac{\Delta p}{\rho}}} \text{ [USgal/min.]}$$

$k_v$	[m <sup>3</sup> /h]	Quantity [m <sup>3</sup> /h] of water flowing through a valve at a pressure loss of 1 bar (according to VDE/VDI Norm 2173).	$C_v$	[US gal/min]	Quantity [US gal/min] of water flowing through a valve at a pressure loss of 1 psi.
$P_1$	[bar]	Pressure before the valve (upstream).	$P_1$	[psi]	Pressure before the valve (upstream).
$P_2$	[bar]	Pressure after the valve (downstream).	$P_2$	[psi]	Pressure after the valve (downstream).
$\Delta p$	[bar]	Actual pressure loss across the valve ( $P_1 - P_2$ ).	$\Delta p$	[psi]	Actual pressure loss across the valve ( $P_1 - P_2$ ).
$G$	[kg/h]	Mass flow through the valve.	$G$	[lb/min]	Mass flow through the valve.
$\dot{V}$	[m <sup>3</sup> /h]	Volume flow through the valve.	$\dot{V}$	[US gal/min]	Volume flow through the valve.
$\rho$	[kg/m <sup>3</sup> ]	Density of the refrigerant before the valve.	$\rho$	[lb/ft <sup>3</sup> ]	Density of the refrigerant before the valve.
$C_A$		Calculation factor (fig. 11).	$C_A$		Calculation factor (fig. 11).

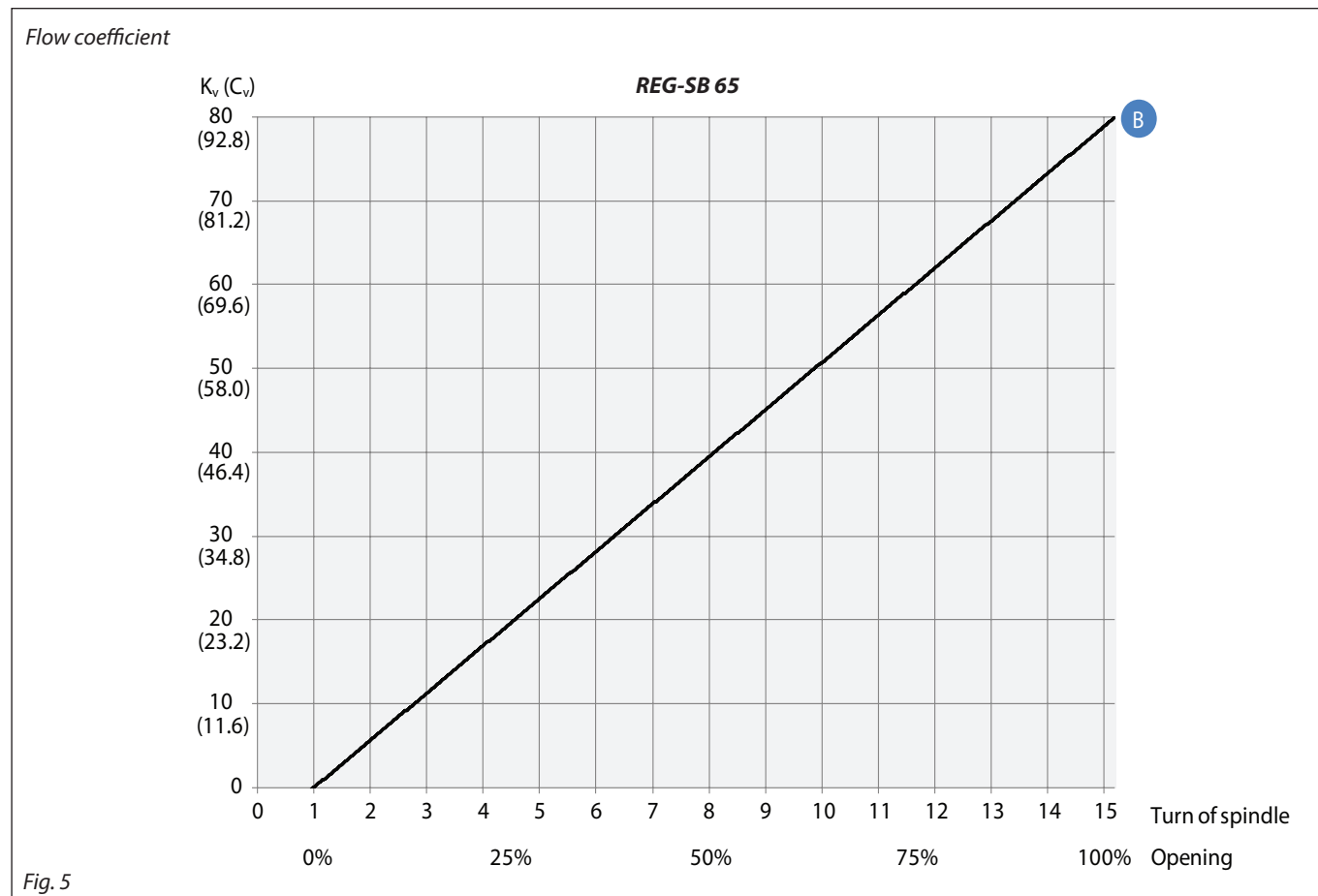
Computation and selection



Computation and selection (Continued)



Computation and selection (Continued)



**Computation and selection**  
(Continued)

Liquid R 717, density: 670 kg/m<sup>3</sup> [42 lb/ft<sup>3</sup>]

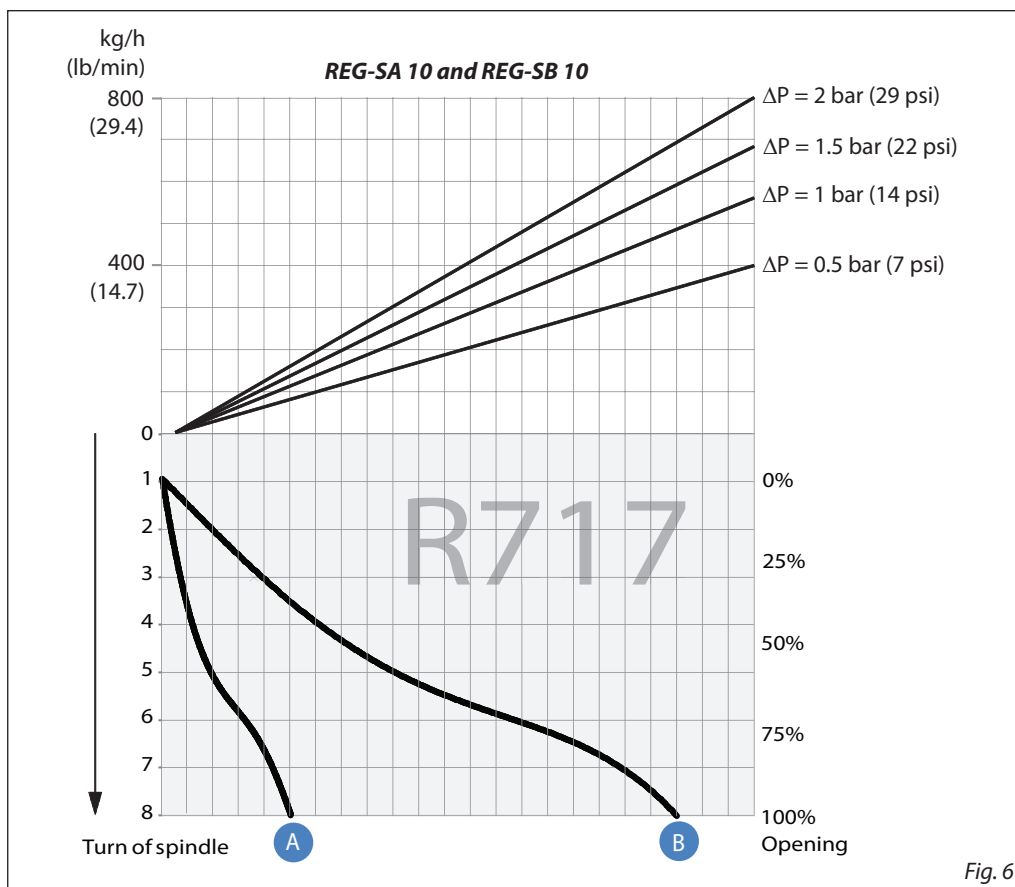


Fig. 6

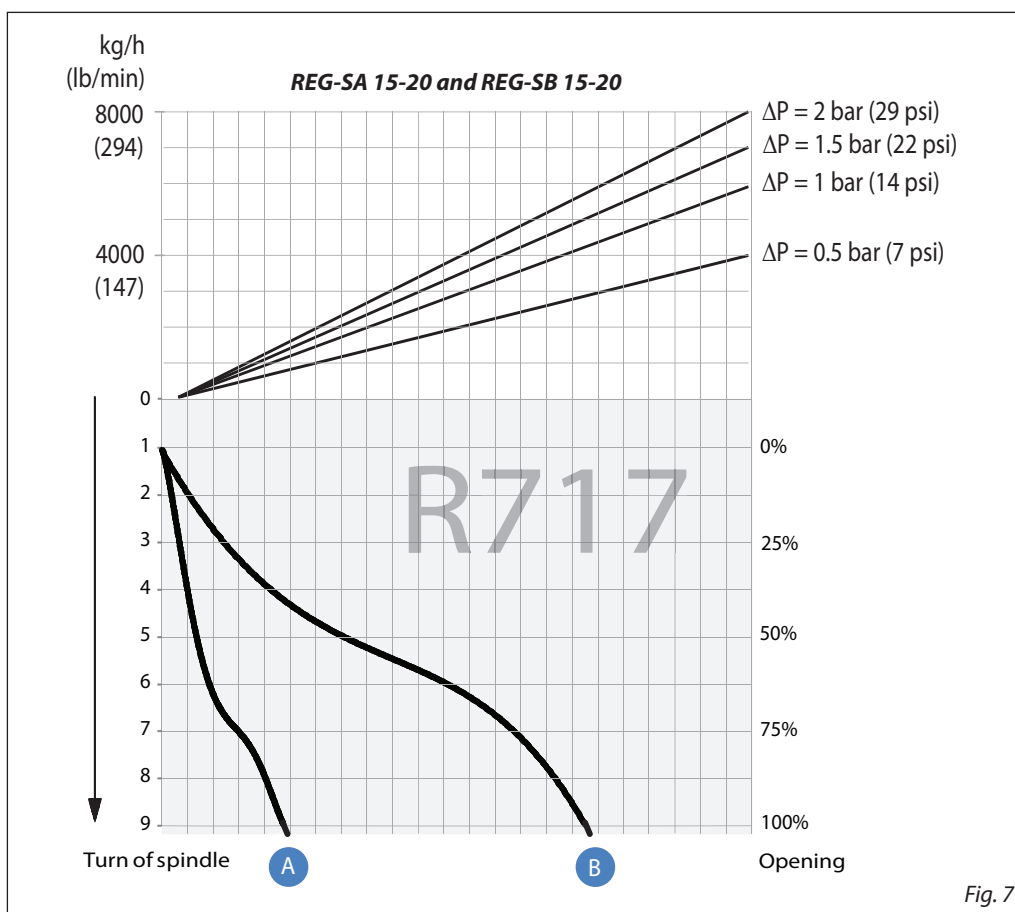


Fig. 7

For choice of valve size and connection see "Connections".

**Computation and selection**  
(Continued)

Liquid R 717, density: 670 kg/m<sup>3</sup> [42 lb/ft<sup>3</sup>]

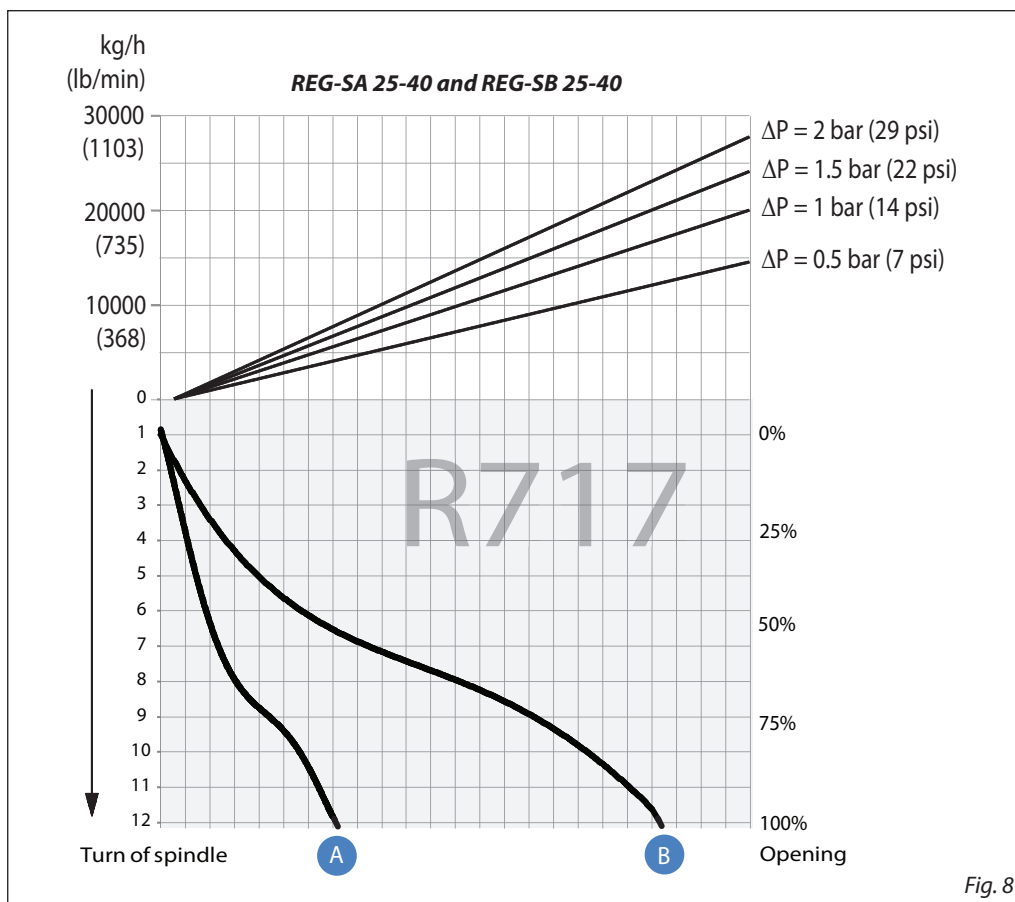


Fig. 8

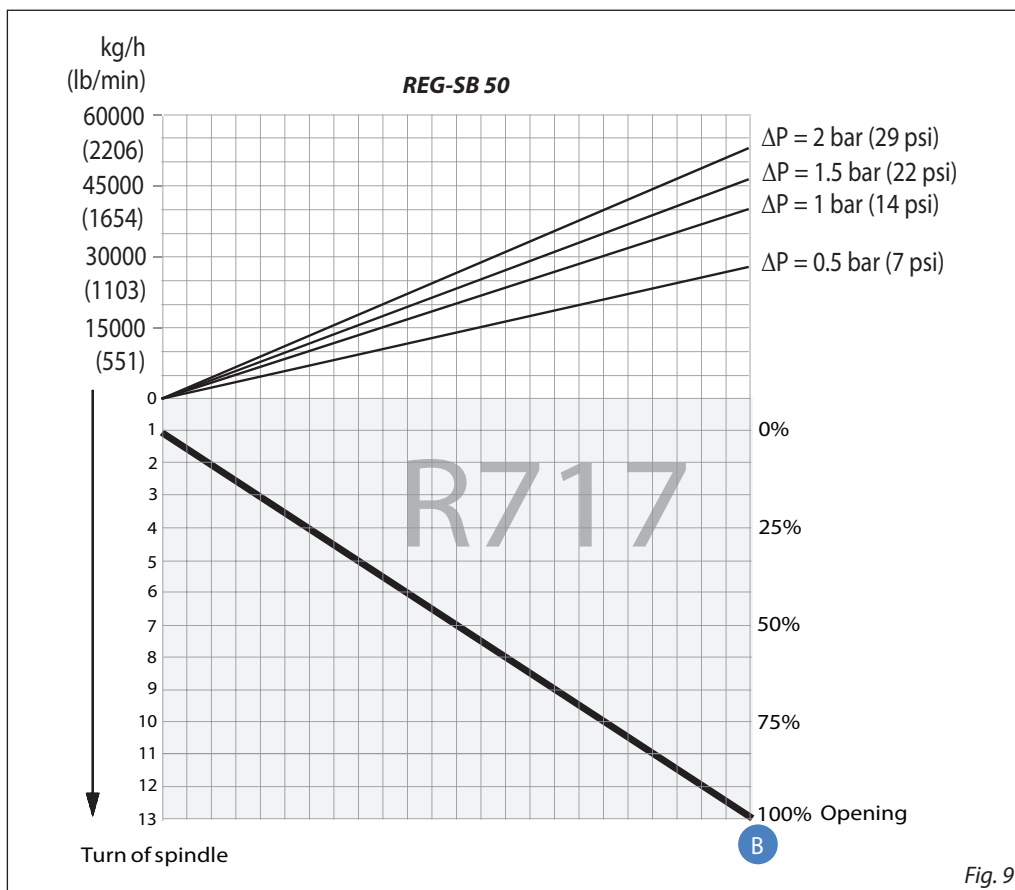


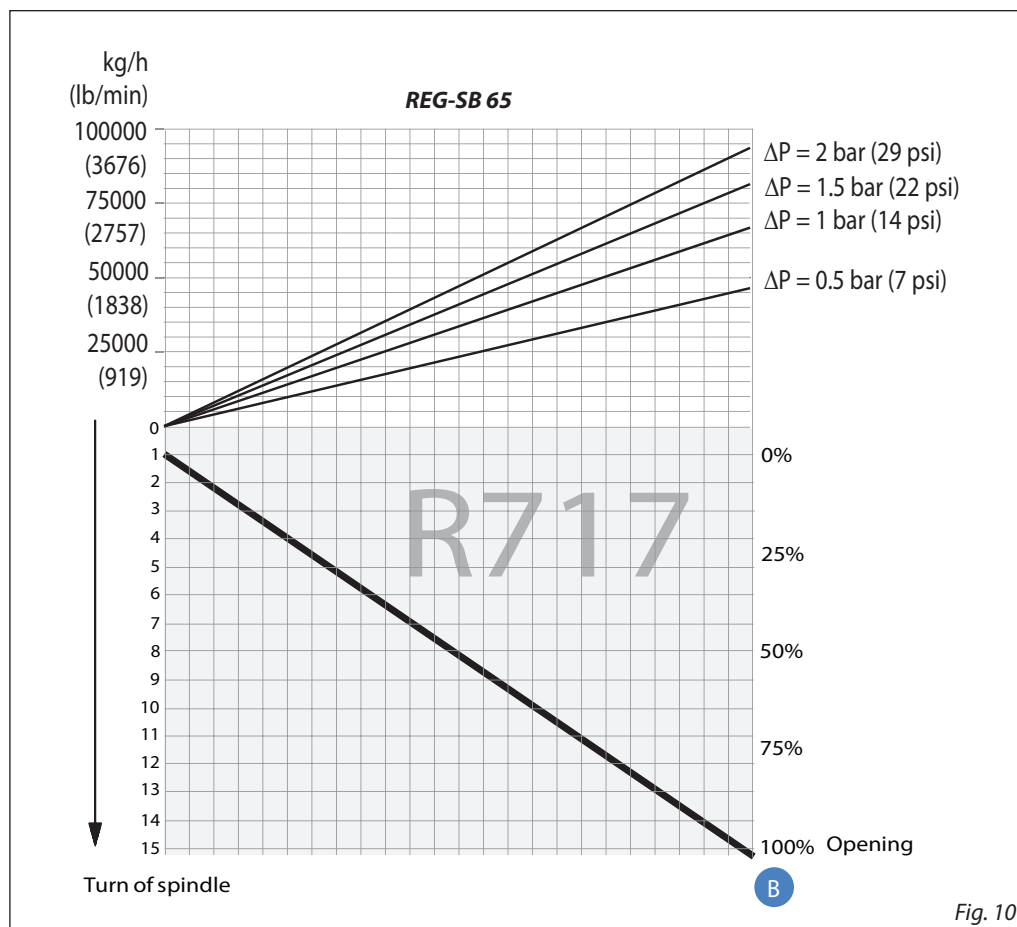
Fig. 9

For choice of valve size and connection see "Connections".

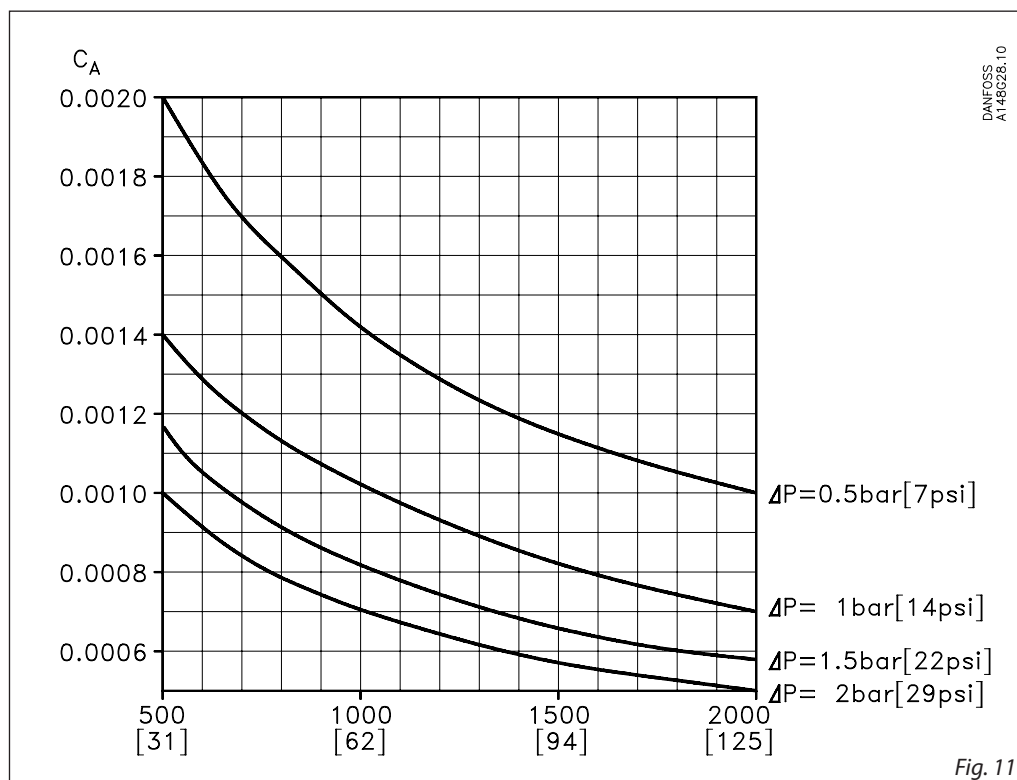


**Computation and selection**  
(Continued)

Liquid R 717, density: 670 kg/m<sup>3</sup> [42 lb/ft<sup>3</sup>]



Calculation factor  $C_A$



For choice of valve size and connection see "Connections".

**Data sheet | Hand operated regulating valves, types REG-SA and REG-SB**

**Computation and selection**

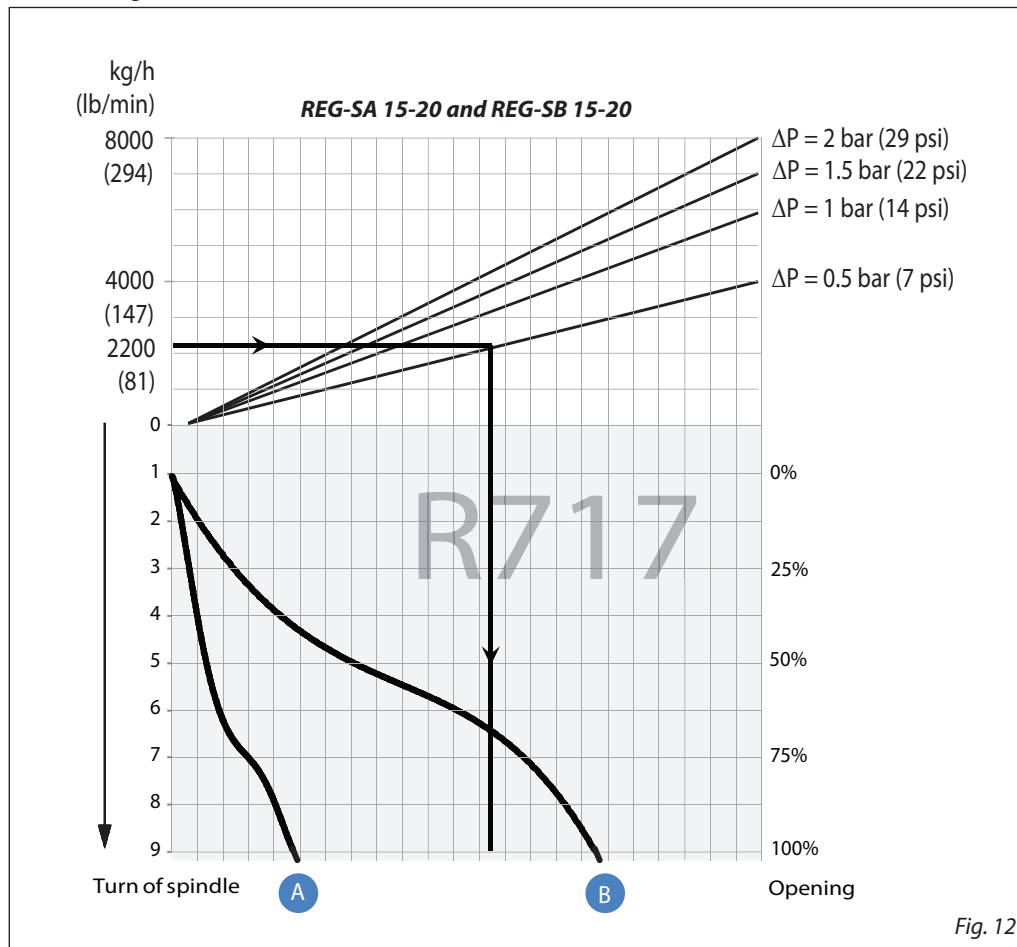
Example 1.

Refrigerant: R 717  
 Refrigerant flow: 2200 kg/h  
 Pressure drop:  $\Delta p = 0.5$  bar

The above mentioned example is illustrated on the following flow rate diagram and shows that REG-SB 15 and 20 with cone B can be used. The main rule is that nominal regulation range should be below 85% opening degree. If the arrowline is crossing 2 cone curves, the smaller cone should be selected if opening degree < 85%.

The example is only correct if the density of the refrigerant is approx. 670 (kg/m<sup>3</sup>), and there must be no build-up of flash gas in the valve.

Flow rate diagram



**Computation and selection**

Example 2.

Brine, density  $\rho$ : 1150 [kg/m<sup>3</sup>]  
 Brine flow  $G$ : 2,700 [kg/h]  
 Pressure drop  $\Delta p$ : 0.5 [bar]

In this example it is not possible to use the selection diagrams (fig. 6 - 10) as the refrigerant in question is not included.

Use the curves of the  $k_v$ -values instead (fig. 1 - 5) and calculate the required  $k_v$  by means of the formulas in the "Introduction" passage at the beginning of this chapter. Alternatively calculate the  $k_v$ -values by means of the calculation factor  $C_A$  (fig. 13) and the flow rate diagram (in this example: fig. 14) as per the following calculation example.

*Calculation example:*

Required  $k_v$ -value  
 $C_A = 0.00132$  (from fig. 18)  
 $k_v = C_A \times G$   
 $k_v = 0.00132 \times 2,700$  [kg/h]  
 $= 3.56$  [m<sup>3</sup>/h]

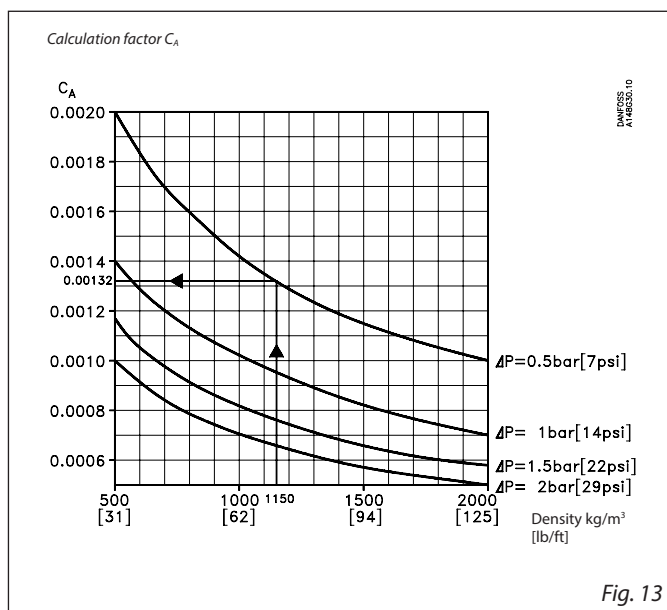


Fig. 13

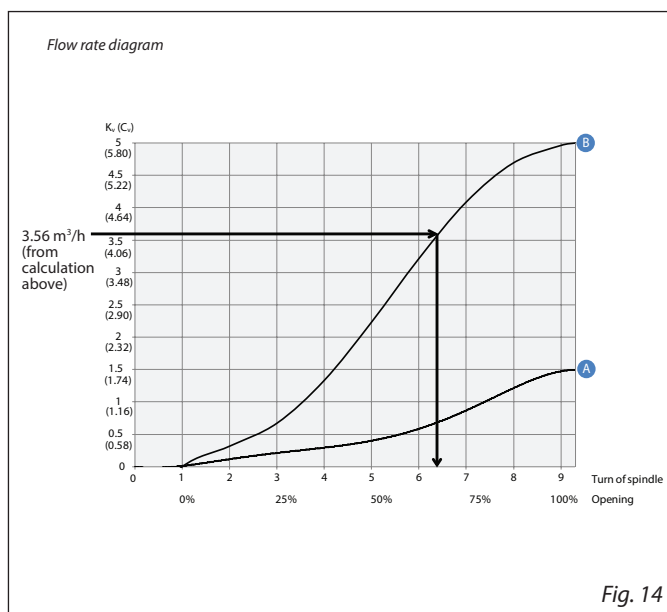
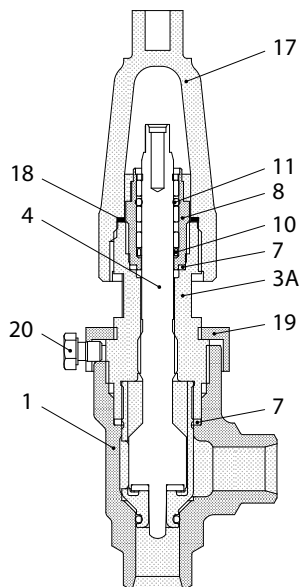


Fig. 14

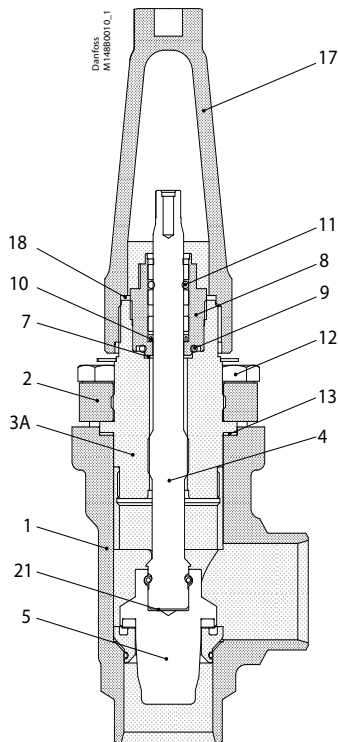
REG-SB 15 and REG-SB 20 with cone B can be used.

Material specification

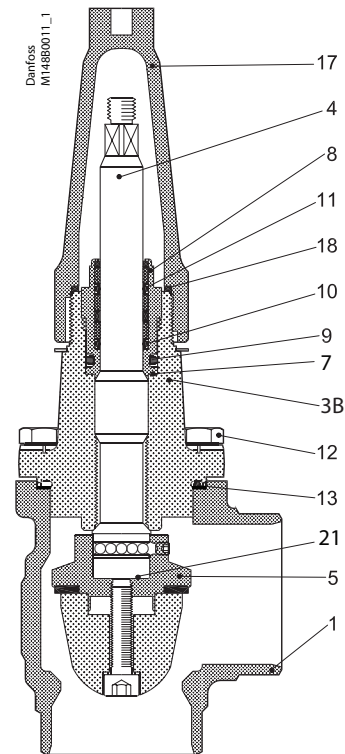
REG-SA and REG-SB 10



REG-SA and REG-SB 15 - 40



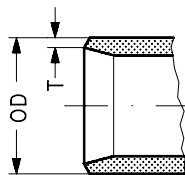
REG-SA and REG-SB 50 - 65



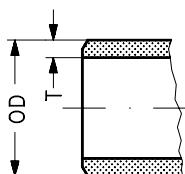
No.	Part	Material	EN	ISO	ASTM
1	Housing	Steel	G20Mn5QT, 10213-3 ----- P285QH+QT, 10222-4		LCC, A352 ----- LF2, A350
2	DN 15 - 40 (½ - 1½ in.) – Bonnet, Flange	Steel	P275 NL EN10028-3		A A662
3A	DN 10 - 40 (¾ - 1½ in.) – Bonnet, Insert	Steel	11SMn30 10087	Type 2, R 683-9	1213 SAE J403
3B	DN 50 - 65 (2 - 2½ in.) – Bonnet, Flange	Steel	P285QH+QT 10222-4		LF2 A350
4	Spindle DN 10 - 65 (¼ - 2½ in.)	Stainless steel	X8CrNiS 18-9, 17440	Type 17, 683/13	AISI 303
5	Cone	Steel			
7	Packing washer	Aluminium			
8	Packing gland	Stainless Steel	X8CrNiS 18-9, 10088	Type 17, 683/13	AISI 303
9	O-ring	Cloroprene (Neoprene)			
10	Spring loaded Teflon ring	PTFE			
11	O-ring	Cloroprene (Neoprene)			
12	Bolts	Stainless steel	A2-70	A2-70	Type 308
13	Gasket	Fiber, non asbestos			
14	Bottom insert	Steel			
17	Seal cap	Aluminium			
18	Gasket f. seal cap	Nylon			
19	Locking nut	Steel			
20	Screw	Steel			
21	Disk spring	Steel			

**Data sheet | Hand operated regulating valves, types REG-SA and REG-SB**
**Connections**

	Size mm	Size in.	OD mm	T mm	OD in.	T in.	Cone
--	---------	----------	-------	------	--------	-------	------

**DIN**

**Butt-weld DIN (EN 10220)**

REG-SA / SB	10	3/8	17.2	2.3	0.677	0.091	A and B
REG-SA / SB	15	1/2	21.3	2.3	0.839	0.091	A and B
	20	3/4	26.9	2.3	1.059	0.091	A and B
REG-SA / SB	25	1	33.7	2.6	1.327	0.103	A and B
	32	1 1/4	42.4	2.6	1.669	0.102	A and B
	40	1 1/2	48.3	2.6	1.902	0.103	A and B
REG-SB	50	2	60.3	2.9	2.37	0.11	B
REG-SB	65	2 1/2	76.1	2.9	3	0.11	B

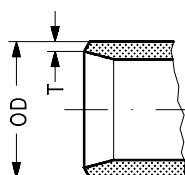
**ANSI**

**Butt-weld ANSI (B 36.10 Schedule 80)**

REG-SA / SB	10	3/8	17.2	3.2	0.677	0.126	A and B
REG-SA / SB	15	1/2	21.3	3.7	0.839	0.146	A and B
	20	3/4	26.9	4.0	1.059	0.158	A and B
REG-SA / SB	25	1	33.7	4.6	1.327	0.181	A and B
	32	1 1/4	42.4	4.9	1.669	0.193	A and B
	40	1 1/2	48.3	5.1	1.902	0.201	A and B

**Butt-weld ANSI (B 36.10 Schedule 40)**

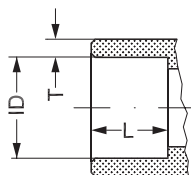
REG-SB	50	2	60.3	3.9	2.37	0.15	B
REG-SB	65	2 1/2	73.0	5.2	2.87	0.20	B

	Size mm	Size in.	OD mm	T mm	OD in.	T in.	Cone
--	---------	----------	-------	------	--------	-------	------

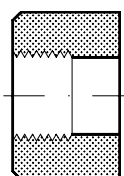
**GOST**

**Butt-weld GOST (8734-75 and 8732-78)**

REG-SA / SB	10	3/8	14	2	0.551	0.079	A and B
REG-SA / SB	15	1/2	18	2	0.709	0.079	A and B
	20	3/4	25	2.5	0.984	0.098	A and B
REG-SA / SB	25	1	32	3	1.260	0.118	A and B
	32	1 1/4	38	3	1.496	0.118	A and B
	40	1 1/2	45	3	1.772	0.118	A and B
REG-SB	50	2	57	3.5	2.244	0.138	B
REG-SB	65	2 1/2	76.1	2.9	3	0.11	B

	Size mm	Size in.	ID mm	T mm	ID in.	T in.	L mm	L in.	Cone
--	---------	----------	-------	------	--------	-------	------	-------	------

**SOC**

**Socket welding ANSI (B 16.11)**

REG-SA / SB	15	1/2	21.8	6.0	0.858	0.235	10	0.39	A and B
	20	3/4	27.2	7.6	1.071	0.299	13	0.51	A and B
REG-SA / SB	25	1	33.9	7.2	1.335	0.284	13	0.51	A and B
	32	1 1/4	42.7	6.1	1.743	0.240	13	0.51	A and B
	40	1 1/2	48.8	6.6	1.921	0.260	13	0.51	A and B
REG-SB	50	2	61.2	6.2	2.41	0.24	16	0.63	B

**FPT**


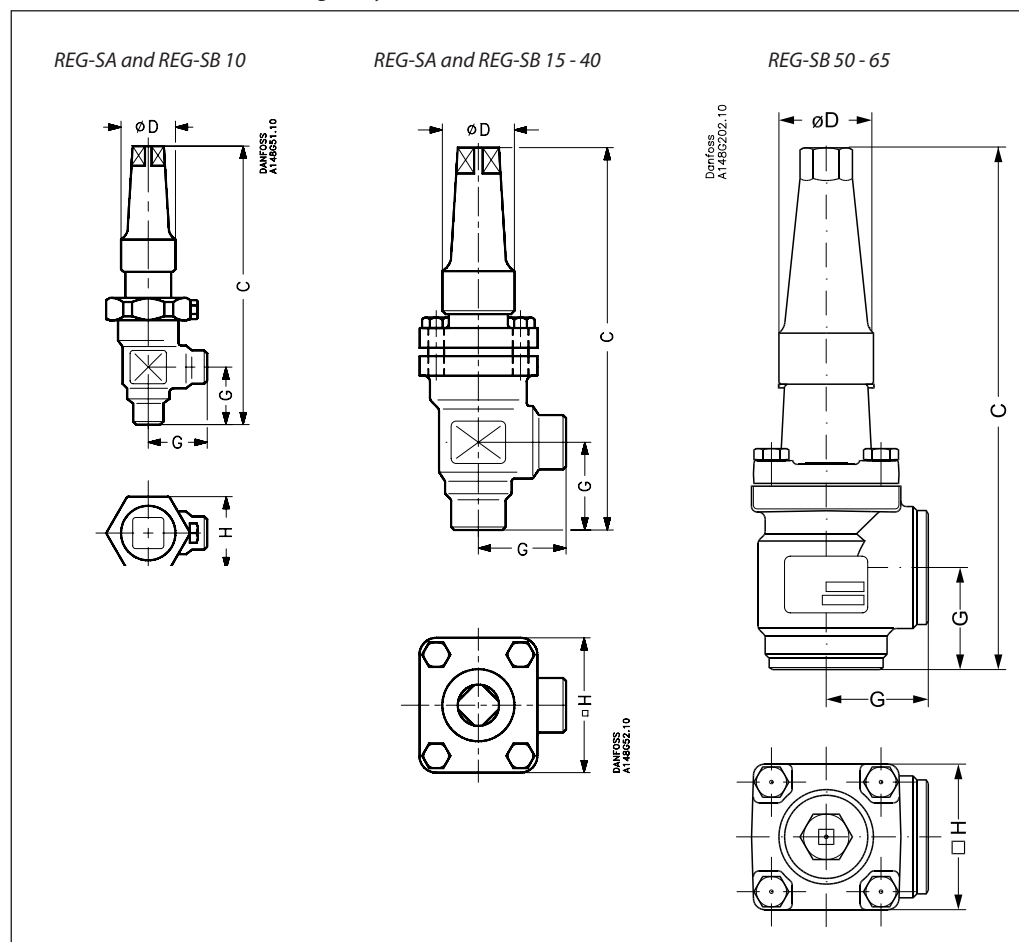
	Size mm	Size in.	Inside pipe thread	Cone
--	---------	----------	--------------------	------

**FPT inside pipe thread, NPT (ANSI/ASME B 1.20.1)**

REG-SA / SB	15	1/2	(1/2 x 14 NPT)	A and B
	20	3/4	(3/4 x 14 NPT)	A and B
REG-SA / SB	25	1	(1 x 11.5 NPT)	A and B
	32	1 1/4	(1 1/4 x 11.5 NPT)	A and B

Dimensions and weights

REG-SA and REG-SB 10 - 65 in angleway version

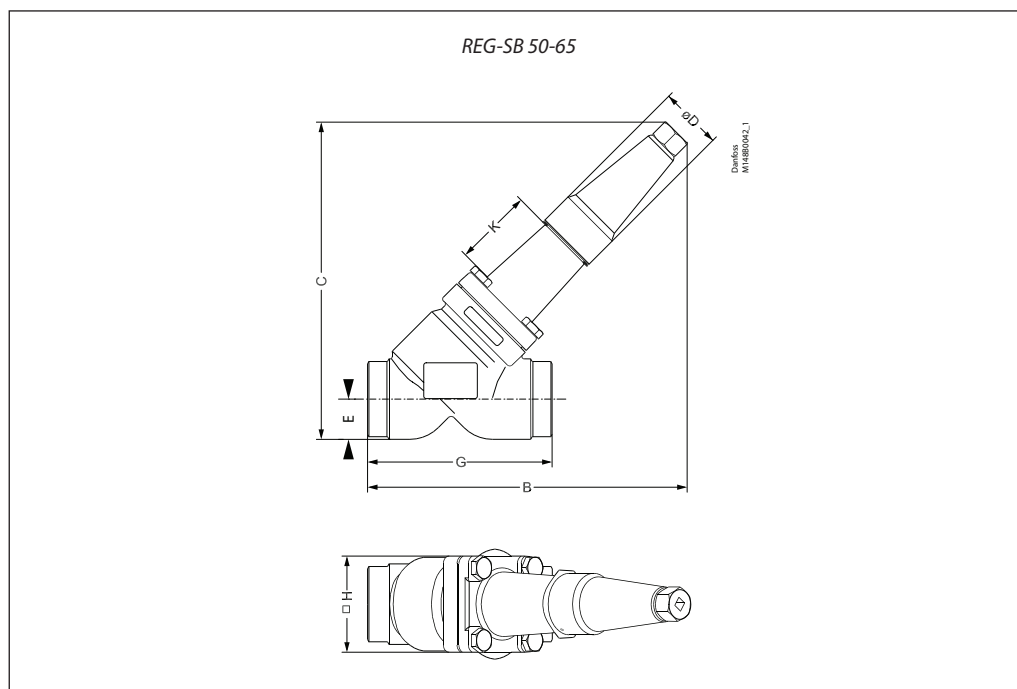
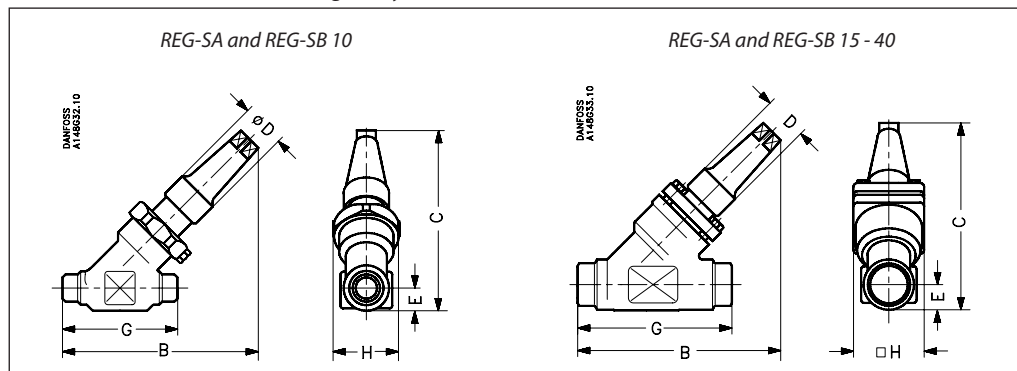


Valve size		C	G	∅D	□H	Weight
REG-SA/SB 10	mm	139	30	30	36	0.8 kg
REG-SA/SB (3/8)	in.	5.47	1.18	1.18	1.42	1.8 lb
REG-SA/SB 15-20	mm	182	45	38	60	1.4 kg
REG-SA/SB (1/2-3/4)	in.	7.17	1.77	1.50	2.36	3.1 lb
REG-SA/SB 25-40	mm	237	55	50	70	2.4 kg
REG-SA/SB (1-1/2)	in.	9.33	2.17	1.97	2.76	5.3 lb
REG-SB 50	mm	315	60	50	77	3.2 kg
REG-SB (2 in.)	in.	12.4	2.36	1.97	3.03	7.1 lb
REG-SB 65	mm	335	70	50	90	4.8 kg
REG-SB (2 1/2 in.)	in.	13.19	2.76	1.97	3.54	10.6 lb
REG-SA/SB 32 SOC	mm	275	62	50	70	2.9 kg
REG-SA/SB (1 1/4 in.) SOC	in.	10.83	2.44	1.97	2.76	6.4 lb
REG-SA/SB 40 SOC	mm	275	62	50	70	2.9 kg
REG-SA/SB (1 1/2 in.) SOC	in.	10.83	2.44	1.97	2.76	6.4 lb
REG-SB 50 SOC	mm.	320	65	50	77	4.1 kg
REG-SB (2 in.) SOC	in.	12.60	2.56	1.97	3.03	9.0 lb

Specified weights are approximate values only.

Dimensions and weights  
(cont.)

REG-SA and REG-SB 10 - 65 in straightway version



Valve size		C	B	E	G		∅D		□H		Weight
REG-SA/SB 10	mm	110	120	13	70		30		36		0.8 kg
REG-SA/SB (3/8)	in.	4.33	4.72	0.51	2.76		1.18		1.42		1.8 lb
REG-SA/SB 15-20	mm	145	155	20	120		38		60		2.0 kg
REG-SA/SB (1/2-3/4)	in.	5.71	6.10	0.79	4.72		1.50		2.36		4.4 lb
REG-SA/SB 25-40	mm	200	215	26	155		50		70		3.0 kg
REG-SA/SB (1-1/2)	in.	7.87	8.46	1.02	6.10		1.97		2.76		6.6 lb
REG-SB 50	mm	257	250	32	148		50		77		4.2 kg
REG-SB (2 in.)	in.	10.12	10.20	1.26	5.83		1.97		3.03		9.3 lb
REG-SB 65	mm	280	284	40	176		50		90		6.3 kg
REG-SB (2 1/2 in.)	in.	11.02	11.18	1.57	6.93		1.97		3.54		13.9 lb
REG 32 SOC	mm	209	222	27.4	155		50		70		3.0 kg
REG (1 1/4) SOC	in.	8.23	8.74	1.08	6.10		1.97		2.76		6.6 lb
REG 40 SOC	mm	213	222	31.0	155		50		70		3.0 kg
REG (1 1/2) SOC	in.	8.39	8.74	1.22	6.10		1.97		2.76		6.6 lb
REG-SB 50 SOC	mm	261	266	37	162		50		77		5.1 kg
REG-SB (2 in.) SOC	in.	10.28	10.47	1.26	6.38		6.38		3.03		11.2 lb

Specified weights are approximate values only.

**Ordering**
*How to order*

The table below is used to identify the valve required.

Please note that the type codes only serve to identify the valves, some of which may not form part of the standard product range. For further information please contact your local Danfoss Sales Company.

*Type codes*

Valve type	REG	Hand operated regulating valves					
Nominal size in mm  (Valve size measured on the connection diameter)	<b>10</b> <b>15</b> <b>20</b> <b>22</b> <b>25</b> <b>32</b> <b>40</b> <b>50</b> <b>65</b>	Available connection types					
			A	D	G	SOC	FPT
		DN 10	x	x	x		
		DN 15	x	x	x	x	x
		DN 20	x	x	x	x	x
		DN 22					
		DN 25	x	x	x	x	x
		DN 32	x	x	x	x	x
		DN 40	x	x	x	x	
		DN 50	x	x	x	x	
DN 65	x	x					
Connections	<b>A</b>	Welding branches: ANSI B 36.10 schedule 80, 15 - 40 (½ - 1½ in.) Welding branches: ANSI B 36.10 schedule 40, 50 - 65 (2 - 2½ in.)					
	<b>D</b>	Welding branches: EN 10220					
	<b>G</b>	Welding branches: GOST (8734-75 and 8732-78)					
	<b>SOC</b>	Socket weld: ANSI B 16.11					
	<b>FPT</b>	NPT inside pipe thread: ANSI/ASME B1.20.1					
Valve housing	<b>ANG</b>	Angle flow					
	<b>STR</b>	Straight flow					
Cone A	Size: DN 10 DN 15 DN 20 DN 25 DN 32 DN 40	Flow area [mm <sup>2</sup> ] 3.02 36.5 36.5 178 178 178					
Cone B	Size: DN 10 DN 15 DN 20 DN 25 DN 32 DN 40 DN 50 DN 65	Flow area [mm <sup>2</sup> ] 16 115 115 531 531 531 822 1978					

*Available combination between valve size, cone type and valve connection*

Size	DN 10 (3/8")		DN 15 (1/2")		DN 20 (3/4")		DN 22 (7/8")		DN 25 (1")		DN 32 (1 1/4")		DN 40 (1 1/2")		DN 50 (2")		DN 65 (2 1/2")	
	A	B	A	B	A	B	A	B	A	B	A	B	A	B	A	B	A	B
<b>DIN</b>	x	x	x	x	x	x			x	x	x	x	x	x		x		x
<b>ANSI</b>	x	x	x	x	x	x			x	x	x	x	x	x		x		x
<b>GOST</b>	x	x	x	x	x	x			x	x	x	x	x	x		x		
<b>SOC</b>			x	x	x	x			x	x	x	x	x	x		x		
<b>FPT</b>			x	x	x	x			x	x	x	x						

x = available



**Ordering**  
(continued)

Example:  
REG-SA (Cone A) 15 DIN  
angleway = **148B5226**

**Important!**  
Where products need to be certified according to specific certification societies or where higher pressures are required, the relevant information should be included at the time of order.

**Complete REG-SA (Cone type A)**

**Butt-weld DIN (EN 10220)**

Size		Type	Code no.
mm	in.		

**Angleway - REG-SA with cone type A**

10	3/8	REG-SA 10 D ANG	<b>148B5102</b>
15	1/2	REG-SA 15 D ANG	<b>148B5226</b>
20	3/4	REG-SA 20 D ANG	<b>148B5326</b>
25	1	REG-SA 25 D ANG	<b>148B5426</b>
32	1 1/4	REG-SA 32 D ANG	<b>148B5527</b>
40	1 1/2	REG-SA 40 D ANG	<b>148B5627</b>

**Butt-weld DIN (EN 10220)**

Size		Type	Code no.
mm	in.		

**Straightway - REG-SA with cone type A**

10	3/8	REG-SA 10 D STR	<b>148B5104</b>
15	1/2	REG-SA 15 D STR	<b>148B5228</b>
20	3/4	REG-SA 20 D STR	<b>148B5328</b>
25	1	REG-SA 25 D STR	<b>148B5428</b>
32	1 1/4	REG-SA 32 D STR	<b>148B5528</b>
40	1 1/2	REG-SA 40 D STR	<b>148B5629</b>

**Butt-weld ANSI (B 36.10 Schedule 80)**

Size		Type	Code no.
mm	in.		

**Angleway - REG-SA with cone type A**

10	3/8	REG-SA 10 A ANG	<b>148B5106</b>
15	1/2	REG-SA 15 A ANG	<b>148B5202</b>
20	3/4	REG-SA 20 A ANG	<b>148B5302</b>
25	1	REG-SA 25 A ANG	<b>148B5402</b>
32	1 1/4	REG-SA 32 A ANG	<b>148B5502</b>
40	1 1/2	REG-SA 40 A ANG	<b>148B5602</b>

**Butt-weld ANSI (B 36.10 Schedule 80)**

Size		Type	Code no.
mm	in.		

**Straightway - REG-SA with cone type A**

10	3/8	REG-SA 10 A STR	<b>148B5116</b>
15	1/2	REG-SA 15 A STR	<b>148B5212</b>
20	3/4	REG-SA 20 A STR	<b>148B5312</b>
25	1	REG-SA 25 A STR	<b>148B5412</b>
32	1 1/4	REG-SA 32 A STR	<b>148B5512</b>
40	1 1/2	REG-SA 40 A STR	<b>148B5612</b>

**Socket welding ANSI (B 16.11)**

Size		Type	Code no.
mm	in.		

**Angleway - REG-SA with cone type A**

15	1/2	REG-SA 15 SOC ANG	<b>148B5204</b>
20	3/4	REG-SA 20 SOC ANG	<b>148B5304</b>
25	1	REG-SA 25 SOC ANG	<b>148B5404</b>
32	1 1/4	REG-SA 32 SOC ANG	<b>148B5504</b>
40	1 1/2	REG-SA 40 SOC ANG	<b>148B5604</b>

**Socket welding ANSI (B 16.11)**

Size		Type	Code no.
mm	in.		

**Straightway - REG-SA with cone type A**

15	1/2	REG-SA 15 SOC STR	<b>148B5214</b>
20	3/4	REG-SA 20 SOC STR	<b>148B5314</b>
25	1	REG-SA 25 SOC STR	<b>148B5414</b>
32	1 1/4	REG-SA 32 SOC STR	<b>148B5514</b>
40	1 1/2	REG-SA 40 SOC STR	<b>148B5614</b>

**FPT inside pipe thread, NPT (ANSI/ASME B 1.20.1)**

Size		Type	Code no.
mm	in.		

**Angleway - REG-SA with cone type A**

15	1/2	REG-SA 15 FTP ANG	<b>148B5206</b>
20	3/4	REG-SA 20 FTP ANG	<b>148B5306</b>
25	1	REG-SA 25 FTP ANG	<b>148B5406</b>
32	1 1/4	REG-SA 32 FTP ANG	<b>148B5506</b>

**FPT inside pipe thread, NPT (ANSI/ASME B 1.20.1)**

Size		Type	Code no.
mm	in.		

**Straightway - REG-SA with cone type A**

15	1/2	REG-SA 15 FTP STR	<b>148B5216</b>
20	3/4	REG-SA 20 FTP STR	<b>148B5316</b>
25	1	REG-SA 25 FTP STR	<b>148B5416</b>
32	1 1/4	REG-SA 32 FTP STR	<b>148B5516</b>

- D = Butt-weld DIN
- A = Butt-weld ANSI
- SOC = Socket weld
- FPT = Inside pipe thread
  
- ANG = Angleway
- STR = Straightway

**Ordering**  
*(continued)*

Example:  
 REG-SB (Cone B) 15 DIN  
 angleway = **148B5227**

**Important!**  
 Where products need to be certified according to specific certification societies or where higher pressures are required, the relevant information should be included at the time of order.

**Complete REG-SB (Cone type B)**
**Butt-weld DIN (EN 10220)**

Size		Type	Code no.
mm	in.		

**Angleway - REG-SB with cone type B**

10	3/8	REG-SB 10 D ANG	<b>148B5103</b>
15	1/2	REG-SB 15 D ANG	<b>148B5227</b>
20	3/4	REG-SB 20 D ANG	<b>148B5327</b>
25	1	REG-SB 25 D ANG	<b>148B5427</b>
32	1 1/4	REG-SB 32 D ANG	<b>148B5526</b>
40	1 1/2	REG-SB 40 D ANG	<b>148B5626</b>
50	2	REG-SB 50 D ANG	<b>148B5726</b>
65	2 1/2	REG-SB 65 D ANG	<b>148B5826</b>

**Butt-weld DIN (EN 10220)**

Size		Type	Code no.
mm	in.		

**Straightway - REG-SB with cone type B**

10	3/8	REG-SB 10 D STR	<b>148B5105</b>
15	1/2	REG-SB 15 D STR	<b>148B5229</b>
20	3/4	REG-SB 20 D STR	<b>148B5329</b>
25	1	REG-SB 25 D STR	<b>148B5429</b>
32	1 1/4	REG-SB 32 D STR	<b>148B5529</b>
40	1 1/2	REG-SB 40 D STR	<b>148B5628</b>

**Butt-weld ANSI (B 36.10 Schedule 80)**

Size		Type	Code no.
mm	in.		

**Angleway - REG-SB with cone type B**

10	3/8	REG-SB 10 A ANG	<b>148B5107</b>
15	1/2	REG-SB 15 A ANG	<b>148B5203</b>
20	3/4	REG-SB 20 A ANG	<b>148B5303</b>
25	1	REG-SB 25 A ANG	<b>148B5403</b>
32	1 1/4	REG-SB 32 A ANG	<b>148B5503</b>
40	1 1/2	REG-SB 40 A ANG	<b>148B5603</b>

**Butt-weld ANSI (B 36.10 Schedule 80)**

Size		Type	Code no.
mm	in.		

**Straightway - REG-SB with cone type B**

10	3/8	REG-SB 10 A STR	<b>148B5117</b>
15	1/2	REG-SB 15 A STR	<b>148B5213</b>
20	3/4	REG-SB 20 A STR	<b>148B5313</b>
25	1	REG-SB 25 A STR	<b>148B5413</b>
32	1 1/4	REG-SB 32 A STR	<b>148B5513</b>
40	1 1/2	REG-SB 40 A STR	<b>148B5613</b>

**Butt-weld ANSI (B 36.10 Schedule 40)**

Size		Type	Code no.
mm	in.		

**Angleway - REG-SB with cone type B**

50	2	REG-SB 50 A ANG	<b>148B5706</b>
65	2 1/2	REG-SB 65 A ANG	<b>148B5806</b>

**Butt-weld ANSI (B 36.10 Schedule 40)**

Size		Type	Code no.
mm	in.		

**Straightway - REG-SB with cone type B**

50	2	REG-SB 50 A STR	<b>148B5724</b>
65	2 1/2	REG-SB 65 A STR	<b>148B5809</b>

**Socket welding ANSI (B 16.11)**

Size		Type	Code no.
mm	in.		

**Angleway - REG-SB with cone type B**

15	1/2	REG-SB 15 SOC ANG	<b>148B5205</b>
20	3/4	REG-SB 20 SOC ANG	<b>148B5305</b>
25	1	REG-SB 25 SOC ANG	<b>148B5405</b>
32	1 1/4	REG-SB 32 SOC ANG	<b>148B5505</b>
40	1 1/2	REG-SB 40 SOC ANG	<b>148B5605</b>
50	2	REG-SB 50 SOC ANG	<b>148B5727</b>

**Socket welding ANSI (B 16.11)**

Size		Type	Code no.
mm	in.		

**Straightway - REG-SB with cone type B**

15	1/2	REG-SB 15 SOC STR	<b>148B5215</b>
20	3/4	REG-SB 20 SOC STR	<b>148B5315</b>
25	1	REG-SB 25 SOC STR	<b>148B5415</b>
32	1 1/4	REG-SB 32 SOC STR	<b>148B5515</b>
40	1 1/2	REG-SB 40 SOC STR	<b>148B5615</b>
50	2	REG-SB 50 SOC STR	<b>148B5725</b>

**FPT inside pipe thread, NPT (ANSI/ASME B 1.20.1)**

Size		Type	Code no.
mm	in.		

**Angleway - REG-SB with cone type B**

15	1/2	REG-SB 15 FTP ANG	<b>148B5207</b>
20	3/4	REG-SB 20 FTP ANG	<b>148B5307</b>
25	1	REG-SB 25 FTP ANG	<b>148B5407</b>
32	1 1/4	REG-SB 32 FTP ANG	<b>148B5507</b>

**FPT inside pipe thread, NPT (ANSI/ASME B 1.20.1)**

Size		Type	Code no.
mm	in.		

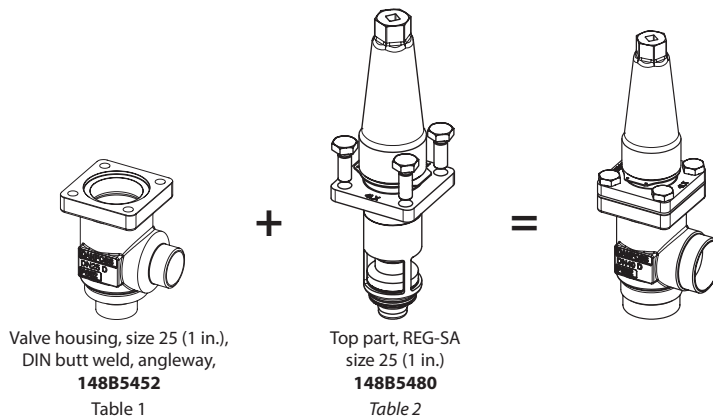
**Straightway - REG-SB with cone type B**

15	1/2	REG-SB 15 FTP STR	<b>148B5217</b>
20	3/4	REG-SB 20 FTP STR	<b>148B5317</b>
25	1	REG-SB 25 FTP STR	<b>148B5417</b>
32	1 1/4	REG-SB 32 FTP STR	<b>148B5517</b>

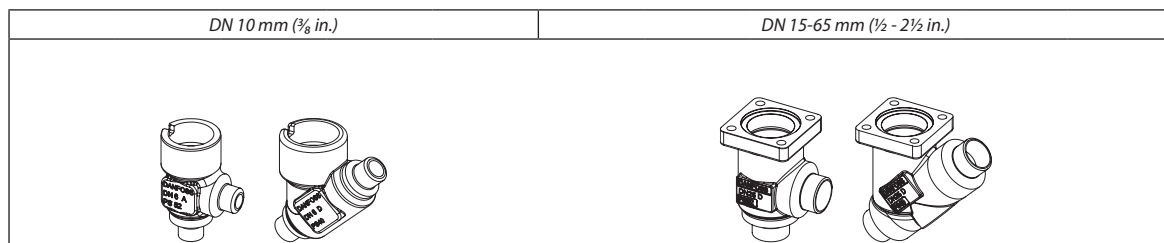
D = Butt-weld DIN  
 A = Butt-weld ANSI  
 SOC = Socket weld  
 FPT = Inside pipe thread  
  
 ANG = Angleway  
 STR = Straightway

Ordering REG-SA/SB from the parts programme

**Example**  
(select from  
table 1 and 2)

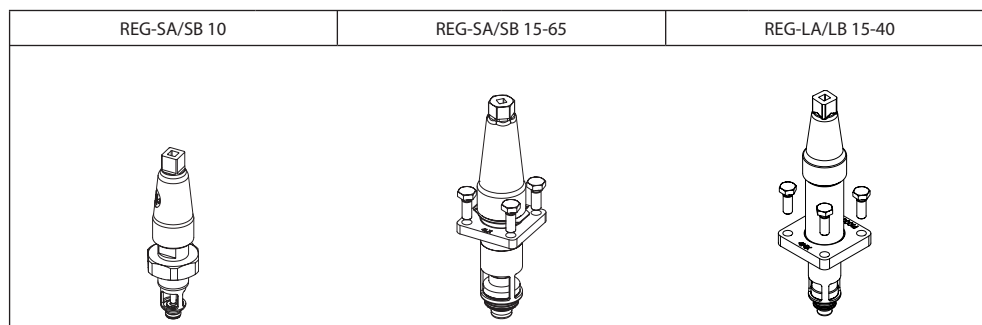


**Table 1**  
SVL valve housings  
w/different  
connections



Sizes [DN]		Valve Housing SVL											
mm	in.	DIN-Butt weld		ANSI-Butt weld		GOST-Butt-weld		SOC		FPT		T	
		ANG	STR	ANG	STR	ANG	STR	ANG	STR	ANG	STR	ANG	
10	3/8	148B5122	148B5123	148B5124	148B5125	148B5134	148B5135						
15	1/2	148B5252	148B5253	148B5254	148B5255	148B5391	148B5392	148B5256	148B5257	148B5258	148B5259		
20	3/4	148B5352	148B5353	148B5354	148B5355	148B5393	148B5394	148B5356	148B5357	148B5358	148B5359		
25	1	148B5452	148B5453	148B5454	148B5455	148B5498	148B5499	148B5456	148B5457	148B5458	148B5459		
32	1 1/4	148B5576	148B5577	148B5578	148B5579	148B5593	148B5594	148B5580	148B5581	148B5582	148B5583		
40	1 1/2	148B5652	148B5653	148B5654	148B5655	148B5681	148B5682	148B5656	148B5657				
50	2	148B5741	148B5742	148B5743	148B5744	148B5759	148B5760	148B5745	148B5746				
65	2 1/2	148B5816	148B5817	148B5818	148B5819	148B5816	148B5817	148B5816	148B5817				

**Table 2**  
REG complete top part  
including gaskets and  
bolts



Sizes [DN]		Complete top part			
mm	in.	REG-SA	REG-SB	REG-LA	REG-LB
10	3/8	148B5112	148B5113		
15	1/2	148B5280	148B5281	148B6401	148B6402
20	3/4				
25	1	148B5480	148B5481	148B6403	148B6404
32	1 1/4				
40	1 1/2		148B5734		
50	2		148B5824		
65	2 1/2				

ENGINEERING  
TOMORROW



---

Danfoss can accept no responsibility for possible errors in catalogues, brochures and other printed material. Danfoss reserves the right to alter its products without notice. This also applies to products already on order provided that such alterations can be made without subsequential changes being necessary in specifications already agreed. All trademarks in this material are property of the respective companies. Danfoss and the Danfoss logotype are trademarks of Danfoss A/S. All rights reserved.