



HS2 Solenoid Valve

Specifications, Applications, Service Instructions & Parts

HS2 SOLENOID VALVE 5/32" (4 mm) PORT

Threaded End
1/4" thru 1/2" FPT
(7 mm thru 15 mm)
1/4" thru 3/4" Flanged
(7 mm thru 20 mm)
for refrigerants



INTRODUCTION

This threaded end industrial refrigeration duty solenoid valve is very simple and compact but rugged in construction. Body is plated steel alloy. The direct lifting stainless steel plunger contains a Teflon seat which closes on a stainless steel orifice. When electrically energized, valve opens wide; when de-energized, flow stops in the direction of the arrow on the valve body.

APPLICATIONS

This small, direct lifting valve is used primarily as a pilot for various larger gas-powered or liquid powered main valves, as a remote pilot for back pressure regulators or other devices, or as a liquid stop valve for expansion valves, float valves, or as a general purpose pilot line for ammonia, R22, R134a, CO2 and other approved refrigerants or oil.

ADDITIONAL FEATURES

- Compact, low cost
- Low wattage, Hansen standard coil
- 300 psi (20 bar) MOPD
- Stainless steel seat orifice
- Removable solenoid tube
- Heavy-duty, direct lift
- CSA Certified
- Non-asbestos gaskets

KEY FEATURES

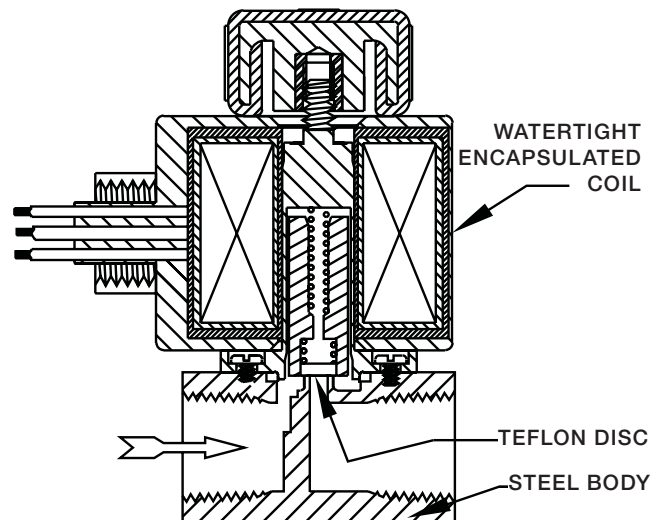

MATERIAL SPECIFICATIONS

Body: Steel, plated

Solenoid Tube: Stainless steel

Plunger: Stainless steel

Seat Orifice: Stainless steel

Seat: Teflon

Safe Working Pressure: 400 psig (27 bar),
600 psig (40 bar) available for CO₂

Operating Temperature: -60°F to +240°F (-50° to
+115°C)

ADVANTAGES

Power-saving, low-wattage encapsulated coil; Teflon disc seat; stainless steel trim; spring-closing. One standard coil fits all Hansen valves. The valve can be installed in vertical lines.

INSTALLATION, THREADED CONNECTION

Match the arrow on the body with the system flow direction. Protect the interior of the valve from dirt during installation. Check mating pipe threads for cleanliness and accuracy before installing. Use a small quantity of pipe dope on pipe threads. Use a flat jaw wrench on the body close to the pipe, being careful not to damage the pipe threads with pipe wrench jaws. Allow 2.25" (57 mm) above the valve for coil removal.

ELECTRICAL

The coil draws 16 watts and will operate properly between 85% and 110% of the rated voltage (24V coil draws 19 watts). Standard coil connection is a 1/2" fitting (NPSM) for conduit, with two 18" wire leads plus ground wire. Coils with DIN plug or 1/2" NPSM quick disconnect plug are available. Contact the factory. All coils are totally encapsulated and meet NEMA 3R (rainproof) and NEMA 4 (splashproof, approx. IP65) requirements. The coil should only be energized while on the solenoid tube. Otherwise, immediate coil burnout may occur. To avoid bending the solenoid tube, remove the coil from the valve before connecting any electrical conduit. Pilot lights are available.

INSTALLATION DIMENSIONS

INCHES (MM)

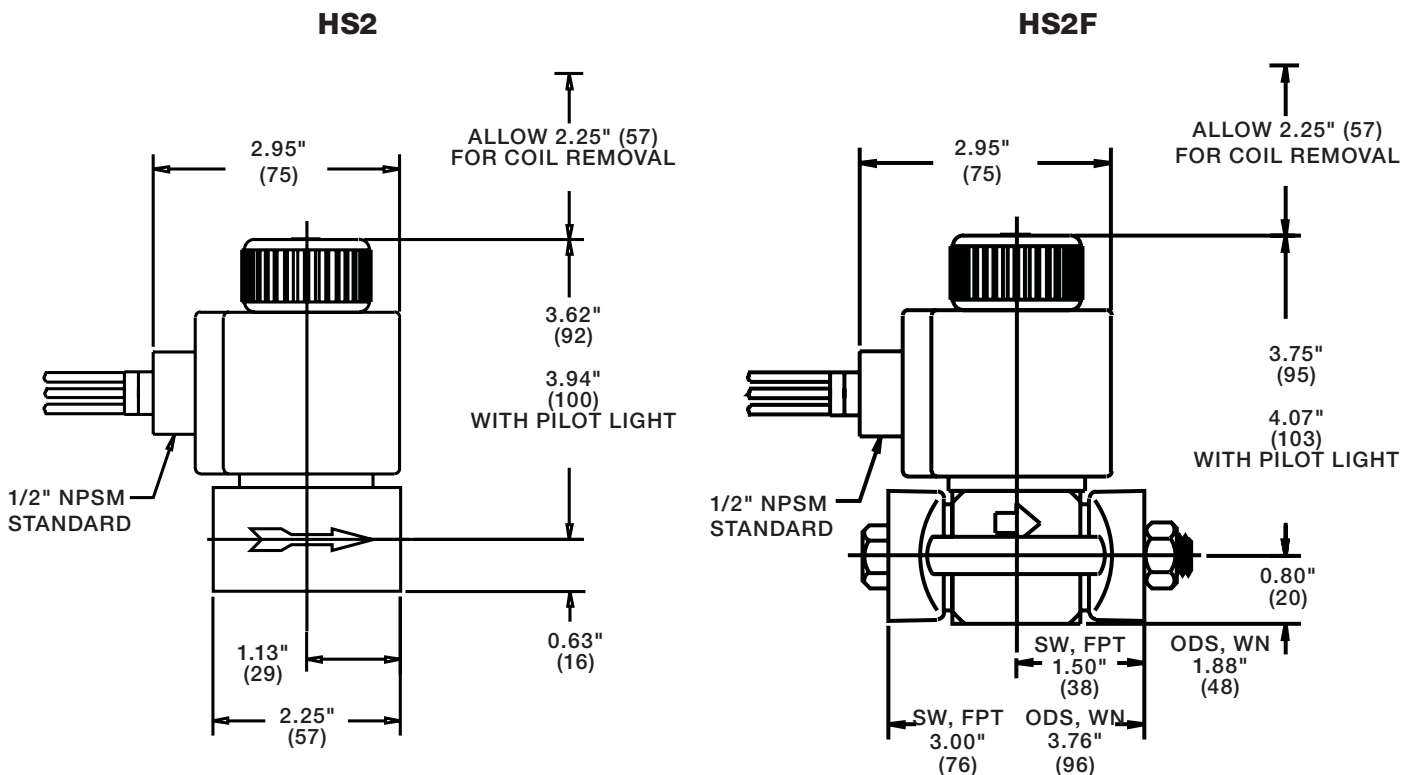

PARTS LIST

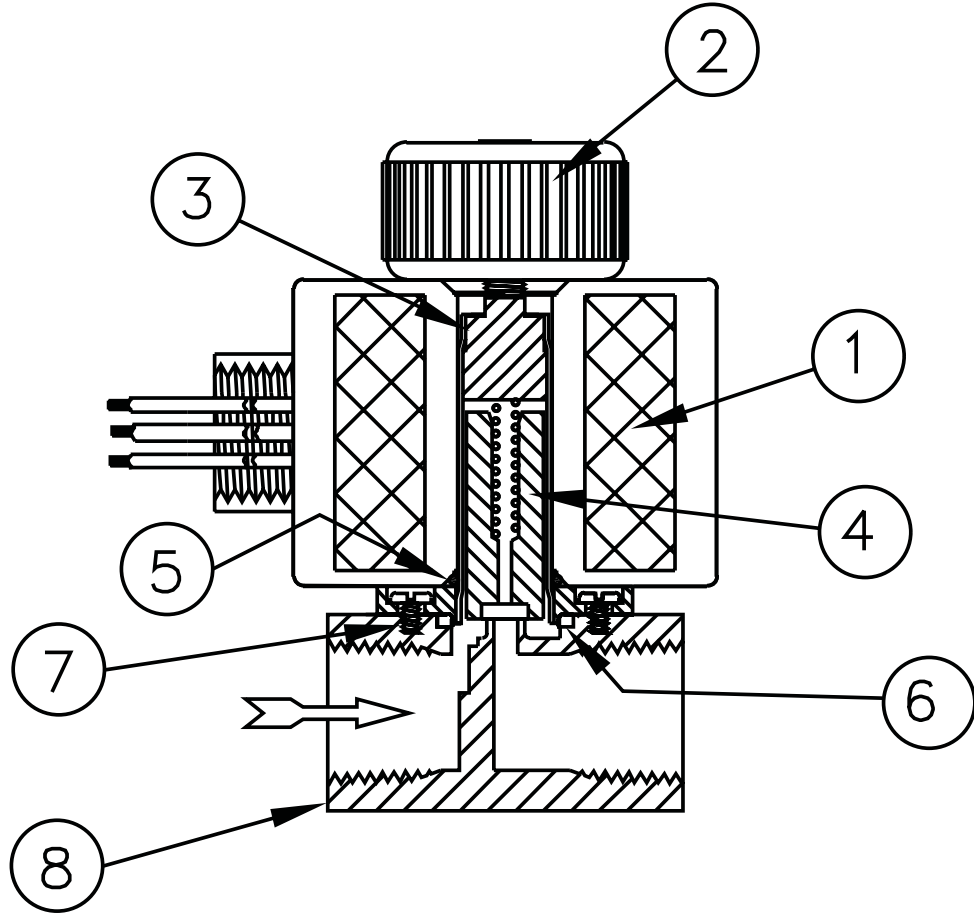

ITEM	DESCRIPTION	QTY	PART NO.
	Coil Kit (115V) 1/2" Fitting w/leads	1	70-1085
	Coil Kit (208/230V) 1/2" Fitting w/leads	1	70-1086
	Coil Kit (24V) 1/2" Fitting w/leads	1	70-1087
	Coil Kit (Other Voltages)	1	FACTORY
	<i>Above kits consist of:</i>		
1a	Bare Coil, 115V 50/60 Hz w/leads	1	70-0580
1b	Bare Coil, 208/230V 50/60Hz w/leads	1	70-0581
1c	Bare Coil, 24V 50/60Hz w/leads	1	70-0582
1d	Other Voltage Coils	1	FACTORY
2	Coil Knob	1	70-0579
	Solenoid Tube/Plunger Kit	1	70-1059
	<i>Above kits consist of:</i>		
3	Solenoid Tube	1	70-0298
4	Plunger	1	70-0295
5	O-Ring	1	75-0340
6	Solenoid Tube Gasket	1	70-0301
7	Screws (4)	4	70-0297

SERVICE AND MAINTENANCE

Failure to open: Wrong voltage coil; low line voltage; controlling switch or thermostat not contacting; coil is burned-out; inlet/outlet pressure differential too high; plunger jammed closed with dirt.

Failure to close: Controlling switch or thermostat not opening contacts; dirt under seat; eroded seat parts; plunger jammed upward by dirt.

Before opening the valve for service, be sure it is isolated from the system and all refrigerant is removed. Disconnect electrical power from the coil. Remove the coil by unscrewing the coil knob. Loosen the four solenoid tube screws sufficiently and break seal, proceeding cautiously to avoid any refrigerant still remaining inside. Remove the tube screws to separate the solenoid tube from the body.

Check face of Teflon seat in plunger, plunger spring, and seat orifice in body. Clean, polish, or replace parts as necessary. Always replace the solenoid tube when replacing the plunger. These are wear parts and must be inspected as part of a routine maintenance program. The seat orifice is integral with the body. Install a new solenoid tube gasket and oil lightly. Reassemble the solenoid tube to the body with four screws. Factory torque is 2 ft-lbs (2.8 Nm). Carefully check the valve for leaks before restoring to service.

CAUTION

Hansen valves are for refrigeration systems only. These instructions must be completely read and understood before selecting, using, or servicing these valves. Only knowledgeable, trained refrigeration mechanics should install, operate, or service these valves. Stated temperature and pressure limits should not be exceeded. Solenoid tubes should not be removed from valves unless the system has been evacuated to zero pressure. See also the Safety Precautions in the current List Price and the Safety Precautions Sheet supplied with product. Escaping refrigerant might cause personal injury, particularly to the eyes and lungs.

WARRANTY

Hansen valves are guaranteed against defective materials or workmanship for one year FOB factory. No consequential damages or field labor is included.

ORDERING INFORMATION

MODEL	CONNECTIONS INCHES (MILLIMETERS)	
	STD	ALSO
HS2	1/2" (15) FPT	1/4" (7), 3/8" (10) FPT
HS2F	1/2" (15) FPT	1/4" (7), 3/8" (10) FPT 1/2" (15), 3/4" (20) SW,WN

FPT: Female Pipe Thread (American National Standard)
SW: Socket Weld to accommodate American and API pipe
WN: Weld Neck to match American Schedule 40 pipe

Standard molded solenoid coil is included for 50/60Hz 208/230, 115, or 24 volts; other voltages offered. Standard coil connection is a 1/2" fitting (NPSM). Coils with DIN plug or 1/2" NPSM quick disconnect plug are available; specify when ordering. Pilot lights are available.

OPTIONAL BEACON PILOT LIGHTS

PILOT LIGHT KIT	
COLOR	PART NO.
Red	70-1100
Amber	70-1101
Green	70-1102



Pilot Light Kit includes Beacon pilot light, knob and o-ring. A/C Coils Only.

TO ORDER:

Specify type, connection type and size, and volts. Unless otherwise specified, standard coil with 1/2" connection will be supplied.

TYPICAL SPECIFICATIONS

"Refrigerant direct operating solenoid valves shall have encapsulated, watertight coils, Teflon seat, steel bodies, spring closing plunger, and be suitable for a safe working pressure of 400 psig (27 bar), model HS2 (HS2F) as manufactured by Hansen Technologies Corporation or approved equal."

HANSEN

Hansen Technologies Corporation
6827 High Grove Boulevard
Burr Ridge, Illinois 60527 USA

Tel: 630.325.1565 Fax: 630.325.1572 Toll: 800.426.7368

Email: info@hantech.com Web: www.hantech.com

USA · Asia · Europe · India · Latin America · Middle East

© 2006 Hansen Technologies Corporation