



aerospace
climate control
 electromechanical
 filtration
 fluid & gas handling
 hydraulics
 pneumatics
 process control
 sealing & shielding



Industrial Refrigeration Control Valves

Catalog C12



ENGINEERING YOUR SUCCESS.

Refrigerating Specialties Division

Parker Industrial's Refrigeration Group (*Refrigerating Specialties and HERRL*) is the premier valve and control supplier to the food and beverage industry.

We've been the world leader in industrial refrigeration for more than 96 years. Our engineering expertise, customer service and manufacturing excellence combine to create a product breadth that is second to none. Products include solenoid valves, pressure regulators, hand valves, liquid level controls, strainers, probes and more.

As the world's population grows, so does the need for large scale, refrigerated food preparation and storage facilities. Food warehouses, meat processing plants, fisheries, dairies, breweries, supermarkets, bottling companies and wineries all rely on Parker industrial refrigeration control valves and system solutions. Keeping industrial machinery cool so that it operates more efficiently, maintaining the freshness of produce during transportation, and preventing mines from flooding are just some of the unique applications of the products Parker offers.



Industrial Refrigeration Control Valves

Our comprehensive product line includes pressure regulators, refrigerant float switches, strainers, automatic flow regulators, solenoid valves, gas powered suction stop valves, check valves, safety relief valves and service valves for both ammonia and halocarbon refrigerants – all built to the highest quality standards recognized throughout the world for durability and reliability.



Product Engineering

Understanding the dynamics of industrial systems and how they affect valve performance is key in the highly specialized refrigeration industry. Innovation, reliability and decades of experience are at the heart of our success. Our superior in-house testing capabilities include a full working ammonia rig and a supermarket rack system.

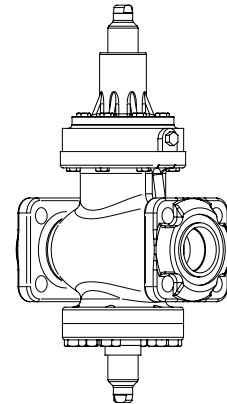

Customer Service

Meeting global customer requirements is our highest priority. Our highly skilled service professionals have extensive valve operation and application knowledge. We provide the solutions our customers need, for their specific application, when they need it.



To Contact Us:

Phone:
(708) 681-6300

Fax:
(708) 681-6306

Website:
www.parker.com/refspec

Table of Contents

A4 Adaptomode ® Pressure Regulators	5	Hand Expansion Valves (HEV)	81
Modules	8	Liquid Overfeed Capacity Tables - Globe "T"	83
A4A/A4W Suction Capacity Tables	10	Liquid Overfeed Capacity Tables - Angle	95
A4A/A4W Liquid Capacity Tables	17	Liquid Overfeed Capacity Tables - Globe "Y"	107
A4A/A4W Oil Capacity Tables	20	Liquid Make Up Capacity Tables - Globe "T"	113
A4AO Hot Gas Bypass Capacity Tables	21	Liquid Make Up Capacity Tables - Angle	119
		Liquid Make Up Capacity Tables - Globe "Y"	125
Adaptor Rings	71	Hot Gas Defrost Valve Capacity Tables	72
Appendix A: Schematic Flow Diagrams	160	Level Master Control (LMC)	154
Appendix B: Dimensional Diagrams	166	Design Precautions	155
Appendix C: Valve Bolt Torque Specifications ..	216	Capacity Tables	157
Appendix D: PED Valve Classification	219	Liquid Level Controls	
Appendix E: Safety Information	221	Liquid Level Control Sensor (HBLC)	136
Check Valves		Liquid Level Sight Glass (SG1)	139
CK-1 General Information	60	Liquid Level Switches (HBSR, HBS01 & HBC2)	135
CK-1 Capacity Tables	61	Liquid Level Transmitter (HBLT-A1)	134
CK-3 General Information	64	Oil Level Control Sensor (HBOC)	137
CK4A General Information	65	Refrigerant Float Switch (LLSS)	138
CK4A Capacity Tables	66	Sight Glass (SA K87 & SA K90)	158
Coil Information	58	Modulating Refrigerant Valve (MVS)	129
Compact Pressure Regulators	22	Liquid Make Up Capacity Tables (LPR)	130
A2 Suction Capacity Tables	24	Liquid Make Up Capacity Tables (HPR)	132
A2 Liquid Capacity Tables	30	Rapid Purger	128
Constant Pressure Expansion Valve (PDA)	159	Refrigerant Distributors	147
Defrost Controller	74	Replaceable Core Filter Dryer	152
Dual Position Control Valves	56	Safety Relief Valves	
S4AD Capacity Tables	35	H Series	75
CK-2D/CK-6D Capacity Tables	49	SR Series	77
Flanges	70	SRH Series	78
Flange Unions	71	SRLQ Series	79
Gas Powered Valves	47	Solenoid Valves	
CK-2/CK-5 Suction Capacity Tables	49	S6N, S8F, SV2, S4A, S5A, S7A General Information	33
S9A/S9W Suction Capacity Tables	52	Capacity Tables	35
Gravity Flooded Capacity Tables	55	XJH & XOP General Information	151
General Information	4	Strainers	
Hand Shut-Off Valves (HV)	80	RSF & RSW General Information	69
		XD & Y General Information	153
		Thermostatic Expansion Valves (TXV)	140
		Capacity Tables	143
		Oil Cooling Thermostatic Charges	145
		Selection Procedure	146

General Information

How to Use this Catalog

This catalog is specific for ammonia refrigeration, but other halocarbon refrigerant sizing tables are available. The catalog is organized by product group. For most sections the first page is an overview followed by product specifications, general information, application guide and selection tables to aid in selecting a specific product. Additional information, in the appendices, provide schematic flow diagrams for regulators, dimensional information on entire product line, valve torque specification and safety information.

Where cold ammonia liquid lines are used, it is necessary that certain precautions be taken to avoid damage that could result from trapped liquid expansion.

- Temperature increase in a valved off piping section completely full of liquid will cause high pressure due to the expanding liquid which can possibly rupture a gasket, pipe or valve.
- All hand valves isolating such sections should be marked, warning against accidental closing, and must not be closed until all liquid is removed.
- Check valves must never be installed upstream of solenoid valves, regulators with electric shut-off, nor should hand valves upstream of solenoid valves or downstream of check valves be closed until all liquid ammonia has been removed.
- It is advisable to install liquid relief devices suitable to safely and automatically bypass any trapped liquid ammonia to the low side of the system. This method is preferred since it operates automatically and requires little attention.
- Avoid all piping or control arrangements that might produce thermal or pressure shock. For the protection of people and products, all refrigerant must be removed from the section to be worked on before a valve, strainer, or other device is opened or removed. Flanges with ODS connections are not suitable for ammonia service.

SAFETY PRACTICES

People doing any work on a refrigeration system must be qualified and completely familiar with the system and the Refrigerating Specialties Division valves involved, or all other precautions will be meaningless. This includes reading and understanding pertinent Refrigerating Specialties Division product Bulletins and Safety Bulletin RSB prior to installation or servicing work.



WARNING: FAILURE OR IMPROPER SELECTION OR IMPROPER USE OF REFRIGERATING SPECIALTIES DIVISION PRODUCTS, ASSEMBLIES OR RELATED ITEMS (“PRODUCTS”) CAN CAUSE DEATH, PERSONAL INJURY, AND PROPERTY DAMAGE. POSSIBLE CONSEQUENCES OF FAILURE OR IMPROPER SELECTION OR IMPROPER USE OF THESE PRODUCTS INCLUDE BUT ARE NOT LIMITED TO:

- Injuries or damage resulting from inhalation or exposure to conveyed fluids
- Injuries from lifting or supporting a heavy item
- Electric shock from contact with live electrically energized components
- Explosion

Before selecting or using any of these Products, it is important that you read and follow the instructions below.

A4 Adaptomode® Series Pressure Regulators

The A4 family of regulators includes valves that control inlet, outlet or differential pressure. Each regulator is available with an assortment of additional variations which enable one regulator to perform several functions. The most common arrangements are shown on the following pages 6 - 7.

Specifications

Body: 20mm -100mm (¾" - 4")	Gray Iron (ASTM A126 Class B)
125mm - 200mm (5" - 8")	Cast Steel (A-352 GR, LCB)
Temperature Range: 20mm -100mm (¾" - 4")	-45°C - 105°C (-50°F - 220°F)
125mm - 200mm (5" - 8")	-50°C - 105°C (-60°F - 220°F)
Maximum Rated Pressure (MRP)	27.6 barg (400 psig)
Maximum Operating Pressure Difference (S Features Only)	20.7 bard (300 psid)

DIN Specifications

Body: 20mm - 100mm (¾" - 4")	Ductile Iron (DIN GGG 40.3)
Temperature Range: 20mm -100mm (¾" - 4")	-45°C - 105°C (-50°F - 220°F)
Maximum Rated Pressure (MRP)	28 barg (406 psig)
Maximum Operating Pressure Difference (S Features Only)	20.7 bard (300 psid)

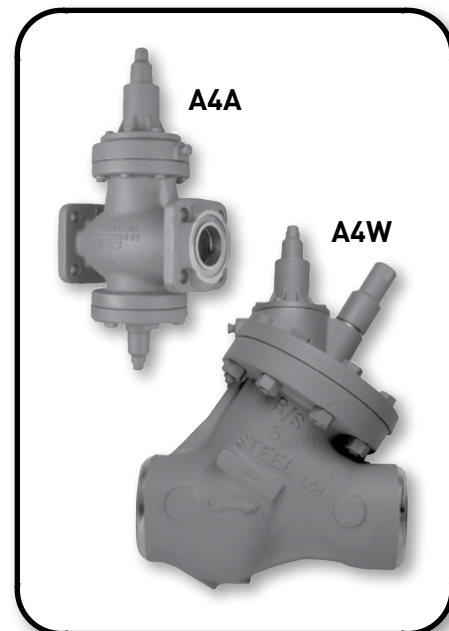

General Information

Port Size		Reduced Capacity Plugs	Type	Flow Coefficient		Connections Available			
mm	inch			Kv	Cv	FPT	SW, WN	ODS	WN (DN)
20	¾	50% 17%	A4A	6.2	7.2	¾", 1", 1¼"	¾", 1", 1¼"	⅞", 1⅛", 1⅜"	20, 25, 32
			A4A	3.1	3.6				
			A4A	1.0	1.2				
25	1	①	A4A	8.6	10	¾", 1", 1¼"	¾", 1", 1¼"	⅞", 1⅛", 1⅜"	20, 25, 32
32	1¼	35%	A4A	15	18	1¼", 1½"	1¼", 1½"	1⅝"	32
			A4A	5.2	6.1				
40	1⅝	35%	A4A	29	33	1½", 2"	1½", 2"	2⅞", 2⅝"	38, 50
			A4A	10	12				
50	2	②	A4A	42	50	1½", 2"	1½", 2"	2⅞", 2⅝"	38, 50
65	2½	35%	A4A	60	70	—	2½", 3"	2⅝", 3⅞"	65, 75
			A4A	21	25				
75	3	35%	A4A	86	100	—	3"	3⅞", 3⅝"	75
			A4A	30	35				
100	4	35%	A4A	130	150	—	4"	4⅞"	100
			A4A	38	44				
125	5	STD	A4W	170	200	—	5" WN only	—	—
150	6	STD	A4W	310	360	—	6" WN only	—	—
200	8	STD	A4W	470	550	—	8" WN only	—	—

Standard connection styles: FPT for 20mm - 50mm (¾" - 2"); SW for 65mm - 100mm (2½" - 4").
Standard size and style will be furnished unless specified otherwise.

① All 20mm (¾") plugs also fit in 25mm (1") valves.

② All 40mm (1⅝") plugs also fit in 50mm (2") valves.

A4 regulators with variations are factory assembled and tested.

A4 Adaptomode® Series Pressure Regulators

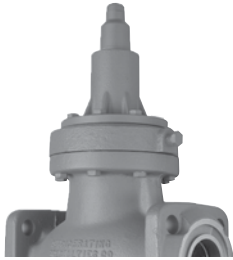

A4A
Basic Inlet



A4AO
Outlet Pressure Regulator



A4AL
Differential Pressure Regulator

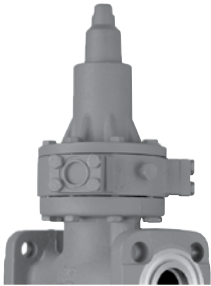

A4AZ
Inlet Pressure Regulator
with Modudapter®

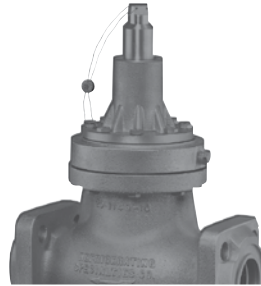

A4AK
Re-seating Relief
Regulator



A4AP
Pneumatically
Compensated Regulator



A4AB
Inlet Pressure Regulator
with Wide Opening Feature



A4AS
Inlet Pressure Regulator
with Electric Shut-Off Feature

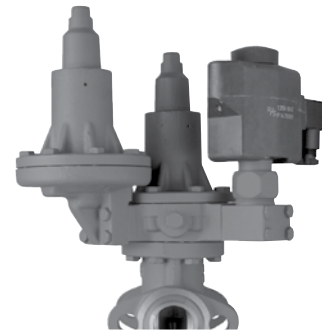

A4AD
Dual Inlet Pressure
Regulator

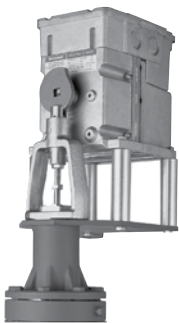

A4AM
Electrically Compensated
Inlet Pressure Regulator



A4AJS
Electronic Pilot Operated
Regulator with Electric
Shut-Off Feature

A4 Adaptomode® Series Pressure Regulators

Application Guide

There are many possible combinations of A4 regulator variations. The electric shut-off (S), electric wide-opening (B) and dual pressure (D) variations are often combined with each other. Or they may be used in combination with the compensated (M, P, 3P and T), outlet pressure (O) or differential pressure (L) regulators. Remote configurations of most variations are available using the A4R regulator separate from pilot controls.

The A4A Series flanged body regulators are available with 20mm - 100mm (3/4" - 4") ports.

The A4W Series weld end body regulators are available with 125mm - 200mm (5" - 8") ports.

Variation	Type Suffix	Type	Function	Operation	Typical Applications
Basic Regulator	—	A4A A4W	Control inlet pressure	Operates at present inlet pressure. Can be field adjusted. Opens on rising inlet pressure.	1. Evaporator pressure control 2. Condenser pressure control 3. Any inlet pressure control
Electric Shut-Off	S	A4AS A4WS	Control inlet pressure or shut off regulator	Regulates when electrically energized; closed when not energized.	1. Open for temperature control 2. Closed for defrosting
Electric Wide Opening	B	A4AB A4WB	Control inlet pressure or wide open regulator	Regulates when not electrically energized; wide open when energized.	1. Wide open for maximum cooling 2. Regulating for defrost 3. Regulating for temperature control.
Dual Pressure	D	A4AD A4WD	Dual pressure control	Regulates at lower pressure when electrically energized; at higher pressure when not energized.	1. Higher pressure for defrost 2. Higher pressure for temperature control. 3. Internal pressure relief.
Re-seating Relief	K	A4AK	Re-seating relief regulator	Open wide above set point. Repeatedly re-seats after operation.	1. Defrost relief 2. Non-atmospheric relief 3. High to low relief
Outlet Pressure Regulator	O	A4AO A4WOE	Control outlet pressure	Regulates at preset outlet pressure. Can be field adjusted. Opens on a drop in outlet pressure.	1. Crankcase pressure regulation 2. Hot gas bypass; booster loading 3. Receiver pressure control
Differential Pressure Regulator	L	A4AL	Control pressure difference across regulator	Regulates pressure difference at or below a pre-set amount.	1. Liquid pump relief regulator 2. Reduce liquid or vapor line pressure
Electrically Compensated	M	A4AM A4WM	Motor changes pressure set-point	Potentiometer or solid state type thermostat readjusts set-point to match evaporator temperature to a varying load.	1. Precise control of process cooling 2. Liquid chillers 3. For load change compensation
Pneumatically Compensated	P 3P	A4AP A4WP A4A3P A4W3P	Air pressure changes set-point (1:1 ratio); A4A3P for 3:1 ratio	Pneumatic thermostat readjusts set-point to match evaporator temperature to a varying load.	1. Precise control of process cooling 2. Liquid chillers 3. For load change compensation
Electronic Pilot Operated	J	A4AJ	Electronic signal controls regulator opening	Pilot position is proportional to electronic signal.	1. Precise control 2. Liquid chiller 3. System with load change
Externally Equalized	E	A4AE A4AOE A4AOES	Control at external pressure sensed remote from valve	Same as standard regulator except controlled pressure is sensed away from regulator.	1. Low Pressure drop (A4AE) 2. Hot gas bypass (A4AOE)
Main regulator for Remote Pilot	R	A4AR A4WR	Main regulator is controlled by separate pilots	Main regulator modulates, closes or opens in response to remote pilots.	1. Simple inventory of regulator and pilots 2. Convenient placement of pilots 3. Unusual pilots or circuits
Basic Regulator Assembly	Z	A4AZ	Complete regulator assembly to which modules can be added.	Can be built into most of the A4A variation regulators. Has a Modudapter® and two Moduplates®.	Versatile unit for inventory along with Adaptomode Modules sold separately.

These are the most common variations of the type A4 regulator. For other combinations, please consult factory.

A4 Adaptomode® Series Pressure Regulators

Moduadapter® (MD, SMD)

The special adapter to which the modular solenoid pilot, modular pressure pilot and Moduplate are bolted.

The Series Moduadapter (SMD) is used with special regulators such as A4ADS, A4ABDS, etc. and with all A4W regulators.

Furnished with bolts and gaskets. (Standard part of regulators with S, B, D and Z variations)

Port Sizes:

- MD25: 20mm - 25mm (3/4" - 1")
- MD32: 32mm (1 1/4")
- MD50: 40mm - 50mm (1 5/8" to 2")
- MD65: 65mm (2 1/2")
- MD75: 75mm (3")
- MD100: 100mm (4")
- SMD65: 20mm - 65mm (3/4" - 2 1/2") and 125mm - 200mm (5" - 8")
- SMD100: 75mm - 100mm (3" - 4")



A2D Modular Pressure Pilot

Adds dual (D) variation when combined with Modular Solenoid Pilot. Provides a second higher control pressure.

Furnished with bolts and O-rings. Mounts to Moduadapter®.

Port Sizes:

- Use A2D2 with 20mm - 25mm (3/4" - 1")
- Use A2D with 65mm - 200mm (2 1/2" - 8")
- Range A:** (standard)
0.35 barg - 10 barg (5 psig - 150 psig)
- Range D:**
5.2 barg - 19.3 barg (75 psig - 280 psig)



Outlet Regulator Kit (OR)

An auxiliary adapter which converts A4A inlet regulators to outlet regulators with OE variation.

Furnished with all internal parts, bolts and gaskets.

Port Sizes:

- OR50 for 20mm - 50mm (3/4" - 2")
- OR200 for 65mm - 200mm (2 1/2" - 8")



Pressure Bonnet Kit (PK)

Converts any A4, A4O or A2 Series regulator to 1:1 Pressure Compensation (P) variation. Standard in A range. Use with Type VC vacuum cartridge for V range.

Also available 3:1 pressure compensation (3P) variation. Furnished with 1/4" FPT bonnet connection for air or refrigerant pressure, bolts and gaskets. 3:1 kit includes above plus auxiliary adapter.

Same for all port sizes.

Type:

- PK1** for 1:1 ratio.
- PK3** for 3:1 ratio



Moduplate® (MP)

Provides blank off or cross-over of pilot circuit on Type A4S or Type A4B.

Attaches to Moduadapter. Same for all regulator sizes.

Furnished with bolts and three O-rings.



Motor Bonnet Kit (MB)

Converts to electric compensation (M) variation any A4 Series regulator. Standard in A range. Combine with VC vacuum cartridge for V range.

Furnished with bonnet, all internal parts, cam, bolts, gaskets, motor and transformer with 24 Volt secondary to operate motor. Same for all port sizes.



Vacuum Cartridge (VC)

A pilot seat with vacuum range cartridge. Will change A range A4, A2B or A2D to vacuum range:

500mm Hg - 8.3 barg (20" Hg - 120 psig)

Furnished with diaphragm and necessary gasket. Same for all regulator sizes.



A4 Adaptomode® Series Pressure Regulators

Pressure Setting Ranges

Code	Set Point Range	Approx. Pressure Change per Turn of Adjustment Screw	Factory Set Point (unless other wise specified)	Factory Set Point "T" (unless other wise specified)
A ①	0.35 - 10 barg (5 - 150 psig)	1.7 barg (25 psig)	2.8 barg (40 psig)	5.5 barg (80 psig)
V	500mm Hg - 8.3 barg (20 in Hg - 120 psig)	1.7 barg (25 psig)	1.0 barg (15 psig)	—
D	5.2 - 19.3 barg (75 - 280 psig)	3.7 barg (53 psig)	9.7 barg (140 psig)	9.7 barg (140 psig)

① Standard

For variations "K" and "BK", the set point is factory set and sealed. Standard set point for each range is shown in the table above. A custom setting may be specified.

Manual Opening and Pressure Adjusting Stem

Port Size		Manual Opening Stem		Pressure Adjusting Stem
mm	inch	Bypass Mode	Regulating Mode	
20 - 100	¾ - 4	Counter-Clockwise	Clockwise	In Increases Set Point
100 - 200	5 - 8	Clockwise	Counter-Clockwise	In Increases Set Point

Suction Capacities - A4

R-717 (KW)

Evap T (°C) P (barg)	Pressure Drop (bar)	20mm ^②	25mm	32mm ^③	40mm ^③	50mm	65mm ^③	75mm ^③	100mm ^③	125mm	150mm	200mm
10° 5.14	0.14	51	70	123	235	349	493	704	951	1409	2536	3874
	0.35	79	110	193	368	546	772	1103	1488	2205	3969	6064
	0.70	110	153	268	512	758	1072	1532	2068	3063	5514	8424
	1.40	150	208	364	694	1029	1455	2079	2807	4158	7485	11435
5° 4.14	0.14	46	64	113	215	319	451	644	869	1288	2319	3542
	0.35	72	101	176	336	498	704	1006	1359	2013	3623	5535
	0.70	100	139	244	465	689	975	1393	1880	2785	5014	7660
	1.40	135	187	327	625	926	1310	1871	2526	3742	6736	10291
0° 3.28	0.14	42	59	103	196	290	411	587	792	1174	2112	3227
	0.35	66	91	160	305	453	640	915	1235	1829	3292	5030
	0.70	91	126	220	421	623	882	1259	1700	2519	4534	6927
-5° 2.53	0.14	38	53	93	178	264	373	532	719	1065	1917	2928
	0.35	60	83	145	276	409	579	827	1117	1654	2978	4549
	0.70	81	113	198	378	560	792	1131	1527	2263	4073	6223
-10° 1.89	0.14	35	48	84	161	238	337	481	649	962	1731	2645
	0.35	54	74	130	249	368	521	744	1004	1488	2678	4092
	0.70	73	101	176	337	499	706	1008	1361	2017	3630	5546
-15° 1.35	0.14	31	43	76	144	214	303	432	584	865	1556	2378
	0.21	38	52	92	175	260	367	525	709	1050	1889	2887
	0.35	48	66	116	222	329	465	665	898	1330	2394	3657
-20° 0.89	0.035	14	20	34	66	97	137	196	265	392	706	1079
	0.14	28	39	68	129	191	271	386	522	773	1391	2126
	0.21	34	47	82	156	232	328	468	632	936	1685	2575
-25° 0.50	0.035 ^①	13	18	31	58	87	123	175	236	350	630	963
	0.14	25	34	60	115	170	240	343	464	687	1236	1888
-30° 0.18	0.035 ^①	11	16	27	52	77	109	155	210	311	559	854
	0.14	22	30	53	101	150	212	303	409	606	1090	1666
-35° <i>-0.08</i>	0.035 ^①	10	14	24	46	68	96	137	185	274	493	753
	0.14	19	26	46	88	131	185	265	358	530	954	1457
-40° <i>-0.30</i>	0.035	8.6	12	21	40	59	84	120	162	240	432	660
	0.14	17	23	40	77	113	161	229	310	459	825	1261

Capacities for R717 are based on 30°C liquid. Capacities are maximum and have no reserve for excess loads. Capacities apply to any A4A or A4W regulator (or S4A and S4W) regardless of variation used.

Sub-cooled liquid: For each 5°C liquid is colder than base temperature, increase table valves 3% for R717.

① 0.034 bar pressure drop capacities apply only to regulators with LPD (low pressure drop) variation.

② The 20mm regulator is available with throttling plug capacities equivalent to approximately 50% and 17% of the ratings in the tables.

③ The 32mm, 40mm, and 65mm - 100mm are available with throttling plug capacities equivalent to approximately 35% of the ratings in the tables.

Note: For liquid overfeed applications (nominal 2:1 to 5:1 ratio), add 20% to the evaporator load and select a regulator based on this increased load value.

Suction Capacities - A4

R-717 (TONS)

Evap T (°F) P (psig)	Pressure Drop (psi)	¾" ②	1"	1¼" ③	1½" ③	2"	2½" ③	3" ③	4"	5"	6"	8"
50° 74.5	2	14	20	35	66	98	139	199	268	398	716	1093
	5	22	31	54	104	154	218	311	420	622	1120	1712
	10	31	43	76	144	214	303	432	584	865	1557	2379
	20	42	59	103	196	291	411	588	793	1175	2115	3231
40° 58.6	2	13	18	31	60	89	126	180	243	360	648	990
	5	20	28	49	94	139	197	281	380	562	1012	1546
	10	28	39	68	130	193	272	389	525	778	1401	2140
	20	38	52	91	175	259	366	523	705	1045	1881	2874
30° 45.0	2	12	16	28	54	80	113	162	219	324	584	892
	5	18	25	44	84	125	177	253	341	505	909	1389
	10	25	35	61	116	172	243	348	469	695	1251	1912
20° 33.5	2	10	15	25	49	72	102	145	196	291	523	799
	5	16	23	39	75	112	158	226	305	451	812	1241
	10	22	31	54	103	152	216	308	416	616	1109	1694
10° 23.8	2	9.3	13	23	43	64	91	130	175	259	466	713
	5	14	20	35	67	99	140	200	270	400	720	1100
	10	19	27	47	90	134	189	270	364	540	972	1484
0° 15.7	2	8.3	11	20	38	57	80	115	155	229	413	631
	3	10	14	24	46	69	97	139	188	278	501	765
	5	13	18	31	59	87	123	176	237	352	633	967
-10° 9.0	0.5 ①	3.7	5.1	9.0	17	25	36	51	69	103	185	282
	2	7.3	10	18	34	50	71	101	136	202	363	555
	3	8.8	12	21	41	60	85	122	165	244	439	671
-20° 3.6	0.5 ①	3.2	4.5	7.9	15	22	32	45	61	90	162	248
	2	6.3	8.8	15	29	44	62	88	119	176	317	484
-30° 1.6 in Hg	0.5 ①	2.8	3.9	6.9	13	19	27	39	53	78	141	216
	2	5.5	7.6	13	25	38	53	76	103	152	274	418
-40° 8.8 in Hg	0.5 ①	2.4	3.4	5.9	11	17	24	34	46	68	122	186
	2	4.7	6.5	11	22	32	45	65	87	130	233	356

Capacities for R717 are based on 86°F liquid. Capacities are maximum and have no reserve for excess loads. Capacities apply to any A4A or A4W regulator (or S4A and S4W) regardless of variation used.

Sub-cooled liquid: For each 10°F liquid is colder than base temperature, increase table values 3% for R717.

① 0.5 psig pressure drop capacities apply only to regulators with LPD (low pressure drop) variation.

② The ¾" regulator is available with throttling plug capacities equivalent to approximately 50% and 17% of the ratings in the tables.

③ The 1¼", 1½", and 2½" - 4" regulators are available with throttling plug capacities equivalent to approximately 35% of the ratings in the tables.

Note: For liquid overfeed applications (nominal 2:1 to 5:1 ratio), add 20% to the evaporator load and select a regulator based on this increased load value.

Suction Capacities - A4

R-22 (KW)

Evap T (°C) P (barg)	Pressure Drop (bar)	20mm ^②	25mm	32mm ^③	40mm ^③	50mm	65mm ^③	75mm ^③	100mm ^③	125mm	150mm	200mm
10° 5.80	0.14 0.7	18 38	24 53	43 93	81 177	120 262	170 371	243 530	328 715	487 1060	876 1908	1338 2915
5° 4.83	0.14 0.7	16 35	22 48	39 85	74 162	110 239	156 339	223 484	301 653	446 967	803 1741	1227 2661
0° 3.97	0.14 0.7	15 32	20 44	36 77	68 147	101 218	143 308	204 440	275 593	408 879	734 1583	1121 2418
-5° 3.20	0.14 0.7	13 29	19 40	32 70	62 133	92 197	130 278	186 398	250 537	371 795	668 1431	1020 2186
-10° 2.53	0.14 0.7	12 26	17 36	29 63	56 119	83 177	118 250	168 357	227 482	337 715	606 1286	926 1965
-15° 1.95	0.14 0.7	11 23	15 32	27 56	51 106	75 158	106 223	152 319	205 430	304 638	547 1148	836 1754
-20° 1.44	0.14 0.35	10 15	14 21	24 37	46 70	68 104	96 147	137 210	185 284	273 421	492 758	752 1157
-25° 1.00	0.14 0.35	8.8 13	12 19	21 33	41 62	61 93	86 131	122 187	165 252	245 374	440 673	673 1029
-30° 0.63	0.035 ^① 0.14	4.0 7.8	5.5 11	10 19	19 36	27 54	39 76	55 109	75 147	111 218	199 392	305 598
-35° 0.31	0.035 ^① 0.14	3.5 6.9	4.9 10	8.6 17	16 32	24 48	34 67	49 96	66 130	98 192	177 346	271 529
-40° 0.04	0.035 ^① 0.14	3.1 6.1	4.3 8.4	7.6 15	15 28	22 42	30 59	43 84	59 114	87 169	156 304	239 464

R-22 (TONS)

Evap T (°F) P (psig)	Pressure Drop (psi)	¾" ^②	1"	1¼" ^③	1½" ^③	2"	2½" ^③	3" ^③	4" ^③	5"	6"	8"
50° 84.1	2 10	5.0 11	7.0 15	12 27	23 51	35 76	49 107	70 153	95 206	140 305	252 549	385 840
40° 68.6	2 10	4.6 10	6.4 14	11 24	21 46	31 68	45 97	64 138	86 186	127 276	229 497	350 759
30° 55.0	2 10	4.1 8.9	5.7 12	10 22	19 41	28 61	40 87	57 124	78 167	115 248	207 446	316 682
20° 43.1	2 10	3.7 8.0	5.2 11	9.1 19	17 37	26 55	36 77	52 111	70 149	104 221	186 398	285 609
10° 32.8	2 10	3.3 7.1	4.6 10	8.1 17	15 33	23 49	32 69	46 98	63 132	93 196	167 353	255 539
0° 24.0	2 5	3.0 4.6	4.1 6.4	7.2 11	14 21	20 32	29 45	41 64	56 86	83 128	149 230	227 351
-10° 16.5	2 5	2.6 4.0	3.7 5.6	6.4 10	12 19	18 28	26 39	37 56	49 76	73 112	132 202	201 309
-20° 10.2	0.5 ^① 2	1.2 2.3	1.6 3.2	2.9 5.6	5.5 11	8.1 16	11 23	16 32	22 44	33 64	59 116	90 177
-30° 4.9	0.5 ^① 2	1.0 2.0	1.4 2.8	2.5 4.9	4.8 9.4	7.1 14	10 20	14 28	19 38	29 56	52 101	79 155
-40° 0.6	0.5 ^① 2	0.9 1.8	1.3 2.4	2.2 4.3	4.2 8.1	6.2 12.1	8.8 17	13 24	17 33	25 49	45 88	69 134

Capacities for R22 are based on 40°C (100°F) liquid and 5°C (10°F) superheat entering the regulator. Capacities are maximum and have no reserve for excess loads. Capacities apply to any A4A or A4W regulator (or S4A and S4W) regardless of variation used.

Sub-cooled liquid: For each 5°C/10°F liquid is colder than base temperature, increase table valves 4% for R22.

① 0.034 bar (0.5 psig) pressure drop capacities apply only to regulators with LPD (low pressure drop) Variation.

② 20mm (¾") regulator is available with throttling plug capacities equivalent to approximately 50% and 17% of the ratings in the tables.

③ The 32mm (1¼"), 40mm (1½"), and 65mm - 100mm (2½" - 4") are available with throttling plug capacities equivalent to approximately 35% of the ratings in the tables.

Note: For liquid overfeed applications (nominal 2:1 to 5:1 ratio), add 20% to the evaporator load and select a regulator based on this increased load value.

Suction Capacities - A4

R-134a (KW)

Evap T (°C) P (barg)	Pressure Drop (bar)	20mm ②	25mm	32mm ③	40mm ③	50mm	65mm ③	75mm ③	100mm ③	125mm	150mm	200mm
10° 3.13	0.14 0.7	14 29	19 41	33 71	64 136	94 202	133 285	190 407	257 550	381 815	686 1466	1047 2240
5° 2.48	0.14 0.7	12 26	17 36	30 64	57 122	85 180	120 255	172 364	232 491	343 728	618 1310	944 2001
0° 1.91	0.14 0.7	11 23	15 32	27 56	51 108	76 160	108 226	154 323	208 436	308 645	555 1162	848 1775
-5° 1.42	0.14 0.7	10 20	14 28	24 50	46 95	68 140	96 198	138 284	186 383	275 567	496 1021	757 1560
-10° 0.99	0.14 0.7	8.8 18	12 25	21 43	41 82	61 122	86 172	122 246	165 332	245 492	441 886	674 1354
-15° 0.63	0.14 0.7	7.8 15	11 21	19 37	36 70	54 104	76 147	108 210	146 284	217 420	390 756	596 1155
-20° 0.31	0.14 0.35	6.9 10	10 14	17 25	32 48	47 70	67 100	95 142	129 192	190 285	343 512	524 783
-25° 0.05	0.14 0.35	6.0 8.8	8.3 12	15 21	28 41	41 60	58 85	83 122	112 164	166 243	299 438	457 670
-30° -0.17	0.035 ① 0.14	2.7 5.2	3.7 7.2	6.5 13	12 24	18 36	26 50	37 72	50 97	75 144	134 259	205 395
-35° -0.35	0.035 ① 0.14	2.3 4.4	3.2 6.1	5.7 11	11 21	16 30	23 43	32 61	44 83	65 123	116 221	178 338
-40° -0.50	0.035 ① 0.14	2.0 3.7	2.8 5.2	4.9 9.1	9.3 17	14 26	19 36	28 52	38 70	56 104	100 187	153 285

R-134a (TONS)

Evap T (°F) P (psig)	Pressure Drop (psi)	3/4" ②	1"	1 1/4" ③	1 5/8" ③	2"	2 1/2" ③	3" ③	4" ③	5"	6"	8"
50° 45.4	2 10	4.0 8.5	5.5 12	10 21	18 39	27 58	39 83	55 118	74 159	110 236	198 424	303 648
40° 35.0	2 10	3.5 7.5	4.9 10	8.6 18	16 35	24 51	34 73	49 104	66 140	98 208	177 374	270 572
30° 26.1	2 10	3.1 6.5	4.4 9.1	7.6 16	15 30	22 45	30 64	44 91	59 123	87 182	157 327	239 500
20° 18.4	2 10	2.8 5.7	3.8 7.9	6.7 14	13 26	19 39	27 55	38 79	52 106	77 157	138 283	211 432
10° 11.9	2 10	2.4 4.8	3.4 6.7	5.9 12	11 22	17 33	24 47	34 67	45 90	67 134	121 241	185 368
0° 6.5	2 5	2.1 3.2	2.9 4.4	5.1 7.7	10 15	14 22	20 31	29 44	40 59	59 88	105 159	161 242
-10° 1.9	2 5	1.8 2.7	2.5 3.7	4.4 6.5	8.4 12	13 18	18 26	25 37	34 50	51 75	91 134	139 205
-20° 3.7 in Hg	0.5 ① 2	0.8 1.6	1.1 2.2	2.0 3.8	3.7 7.2	5.5 11	7.8 15	11 22	15 29	22 43	40 78	61 119
-30° 9.8 in Hg	0.5 ① 2	0.7 1.3	1.0 1.8	1.7 3.2	3.2 6.1	4.7 9.0	6.7 13	10 18	13 25	19 36	34 66	53 100
-40° 14.8 in Hg	0.5 ① 2	0.6 1.1	0.8 1.5	1.4 2.6	2.7 5.0	4.0 7.5	5.7 11	8.1 15	11 20	16 30	29 54	44 83

Capacities for R134a are based on 40°C (100°F) liquid and 5°C (10°F) superheat entering the regulator. Capacities are maximum and have no reserve for excess loads. Capacities apply to any A4A or A4W regulator (or S4A and S4W) regardless of variation used.

Sub-cooled liquid: For each 5°C/10°F liquid is colder than base temperature, increase table values 4% for R134a.

① 0.034 bar (0.5 psig) pressure drop capacities apply only to regulators with LPD (low pressure drop) Variation.

② 20mm (3/4") regulator is available with throttling plug capacities equivalent to approximately 50% and 17% of the ratings in the tables.

③ The 32mm (1 1/4"), 40mm (1 5/8"), and 65mm - 100mm (2 1/2" - 4") are available with throttling plug capacities equivalent to approximately 35% of the ratings in the tables.

Note: For liquid overfeed applications (nominal 2:1 to 5:1 ratio), add 20% to the evaporator load and select a regulator based on this increased load value.

Suction Capacities - A4

R-404a (KW)

Evap T (°C) P (barg)	Pressure Drop (bar)	20mm ^②	25mm	32mm ^③	40mm ^③	50mm	65mm ^③	75mm ^③	100mm ^③	125mm	150mm	200mm
10° 7.26	0.14 0.7	15 33	21 46	37 80	70 152	103 226	146 319	209 456	282 616	417 912	751 1641	1147 2508
5° 6.11	0.14 0.7	14 30	19 41	33 72	63 138	94 204	132 288	189 412	255 556	378 824	681 1483	1040 2265
0° 5.09	0.14 0.7	12 27	17 37	30 65	57 124	85 183	120 259	171 370	231 500	342 741	615 1334	939 2038
-5° 4.18	0.14 0.7	11 24	15 33	27 58	51 111	76 164	108 232	154 332	207 448	307 663	553 1194	845 1824
-10° 3.38	0.14 0.7	10 21	14 30	24 52	46 99	68 146	96 207	138 295	186 398	275 590	496 1063	757 1624
-15° 2.67	0.14 0.7	8.8 19	12 26	21 46	41 87	61 129	86 183	123 261	166 352	246 522	442 940	676 1436
-20° 2.06	0.14 0.35	7.9 12	11 17	19 30	36 56	54 84	76 118	109 169	147 228	218 338	393 608	600 928
-25° 1.52	0.14 0.35	6.9 11	10 15	17 26	32 50	48 73	67 104	96 148	130 200	193 297	347 534	530 816
-30° 1.06	0.035 ^① 0.14	3.1 6.1	4.3 8.5	7.5 15	14 28	21 42	30 59	43 85	58 114	86 169	154 304	236 465
-35° 0.67	0.035 ^① 0.14	2.7 5.3	3.8 7.4	6.6 13	13 25	19 37	26 52	38 74	51 100	75 147	135 265	206 406
-40° 0.34	0.035 ^① 0.14	2.4 4.6	3.3 6.4	5.7 11	11 21	16 32	23 45	33 64	44 86	65 128	118 230	180 351

R-404a (TONS)

Evap T (°F) P (psig)	Pressure Drop (psi)	3/4" ^②	1"	1 1/4" ^③	1 5/8" ^③	2"	2 1/2" ^③	3" ^③	4" ^③	5"	6"	8"
50° 105.3	2 10	4.4 10	6.1 13	11 23	20 45	30 66	43 93	61 133	82 180	122 267	220 480	335 733
40° 86.9	2 10	3.9 8.6	5.5 12	10 21	18 40	27 59	38 83	55 119	74 161	109 238	197 429	301 655
30° 70.7	2 10	3.5 7.6	4.9 11	8.6 19	16 35	24 52	34 74	49 106	66 143	98 212	176 381	269 583
20° 56.6	2 10	3.1 6.7	4.3 9.4	7.6 16	15 31	22 46	30 66	43 94	59 126	87 187	156 337	239 515
10° 44.3	2 10	2.8 5.9	3.8 8.2	6.7 14	13 27	19 41	27 58	38 82	52 111	77 164	138 296	211 452
0° 33.7	2 5	2.4 3.8	3.4 5.2	5.9 9.2	11 18	17 26	24 37	34 52	46 71	68 105	122 189	186 288
-10° 24.6	2 5	2.1 3.3	3.0 4.6	5.2 8.0	10 15	15 23	21 32	30 46	40 62	59 91	106 164	163 251
-20° 16.8	0.5 ^① 2	0.9 1.8	1.3 2.6	2.3 4.5	4.3 8.6	6.4 13	9.1 18	13 26	18 35	26 51	47 92	72 141
-30° 10.3	0.5 ^① 2	0.8 1.6	1.1 2.2	2.0 3.9	3.8 7.4	5.6 11	7.9 15	11 22	15 30	22 44	40 80	62 122
-40° 4.9	0.5 ^① 2	0.7 1.4	1.0 1.9	1.7 3.3	3.2 6.3	4.8 9.3	6.8 13	10 19	13 25	19 38	35 68	53 104

Capacities for R404a are based on 40°C (100°F) liquid and 5°C (10°F) superheat entering the regulator. Capacities are maximum and have no reserve for excess loads. Capacities apply to any A4A or A4W regulator (or S4A and S4W) regardless of variation used.

Sub-cooled liquid: For each 5°C/10°F liquid is colder than base temperature, increase table valves 4% for R404a.

① 0.034 bar (0.5 psig) pressure drop capacities apply only to regulators with LPD (low pressure drop) Variation.

② 20mm (3/4") regulator is available with throttling plug capacities equivalent to approximately 50% and 17% of the ratings in the tables.

③ The 32mm (1 1/4"), 40mm (1 5/8"), and 65mm - 100mm (2 1/2" - 4") are available with throttling plug capacities equivalent to approximately 35% of the ratings in the tables.

Note: For liquid overfeed applications (nominal 2:1 to 5:1 ratio), add 20% to the evaporator load and select a regulator based on this increased load value.

Suction Capacities - A4

R-410a (KW)

Evap T (°C) P (barg)	Pressure Drop (bar)	20mm Ⓣ	25mm	32mm Ⓣ	40mm Ⓣ	50mm	65mm Ⓣ	75mm Ⓣ	100mm Ⓣ	125mm	150mm	200mm
10° 9.87	0.14 0.7	21 47	29 65	51 113	98 216	146 320	206 453	294 647	397 873	589 1293	1059 2328	1618 3557
5° 8.35	0.14 0.7	19 43	27 59	47 104	90 198	134 293	189 414	270 592	364 799	540 1183	972 2130	1484 3254
0° 6.99	0.14 0.7	18 39	25 54	43 94	82 180	122 267	173 377	247 539	333 728	493 1079	888 1941	1357 2966
-5° 5.79	0.14 0.7	16 35	22 49	39 86	75 163	111 242	157 343	225 489	303 661	450 979	809 1762	1236 2692
-10° 4.73	0.14 0.7	15 32	20 44	36 77	68 148	101 219	143 310	204 442	276 597	408 884	735 1592	1122 2432
-15° 3.80	0.14 0.7	13 29	18 40	32 70	62 133	91 197	129 278	185 397	249 536	369 795	664 1431	1015 2186
-20° 2.99	0.14 0.35	12 19	17 26	29 45	55 86	82 128	116 181	166 259	224 349	332 517	598 931	914 1422
-25° 2.29	0.14 0.35	11 17	15 23	26 40	50 77	74 114	104 162	149 231	201 312	298 462	536 831	819 1270
-30° 1.69	0.035 Ⓣ 0.14	4.8 9.6	6.7 13	12 23	22 44	33 66	47 93	67 133	91 179	134 266	242 478	369 730
-35° 1.18	0.035 Ⓣ 0.14	4.3 8.5	6.0 12	10.4 21	20 39	30 58	42 82	60 118	81 159	119 235	215 424	328 647
-40° 0.74	0.035 Ⓣ 0.14	3.8 7.5	5.3 10.4	9.2 18	18 35	26 51	37 73	53 104	71 140	105 207	190 373	290 570

R-410a (TONS)

Evap T (°F) P (psig)	Pressure Drop (psi)	3/4" Ⓣ	1"	1 1/4" Ⓣ	1 5/8" Ⓣ	2"	2 1/2" Ⓣ	3" Ⓣ	4" Ⓣ	5"	6"	8"
50° 143.2	2 10	6.1 14	8.5 19	15 33	29 63	42 93	60 131	85 188	115 253	171 375	307 675	469 1032
40° 118.8	2 10	5.6 12	7.8 17	14 30	26 57	38 84	54 119	78 170	105 229	155 340	279 612	426 935
30° 97.4	2 10	5.1 11	7.0 15	12 27	23 51	35 76	49 107	70 153	95 207	140 307	253 552	386 843
20° 78.7	2 10	4.6 9.9	6.3 14	11 24	21 46	31 68	44 96	63 138	85 186	126 275	228 495	348 756
10° 62.4	2 10	4.1 8.8	5.7 12	9.9 21	19 41	28 61	40 86	57 123	77 166	113 245	204 441	312 674
0° 48.4	2 5	3.6 5.7	5.1 7.9	8.9 14	17 26	25 39	35 55	51 79	68 106	101 158	182 284	278 434
-10° 36.5	2 5	3.2 5.0	4.5 7.0	7.9 12	15 23	22 35	31 49	45 70	61 94	90 140	162 251	247 384
-20° 26.3	0.5 Ⓣ 2	1.4 2.9	2.0 4.0	3.5 6.9	6.7 13	9.9 20	14 28	20 40	27 53	40 79	72 143	110 218
-30° 17.8	0.5 Ⓣ 2	1.3 2.5	1.8 3.5	3.1 6.1	5.9 11.6	8.7 17	12 24	18 35	24 47	35 69	63 125	97 191
-40° 10.8	0.5 Ⓣ 2	1.1 2.2	1.5 3.0	2.7 5.3	5.1 10.1	7.6 15	11 21	15 30	21 41	31 60	55 109	84 166

Capacities for R410a are based on 40°C (100°F) liquid and 5°C (10°F) superheat entering the regulator. Capacities are maximum and have no reserve for excess loads. Capacities apply to any A4A or A4W regulator (or S4A and S4W) regardless of variation used.

Sub-cooled liquid: For each 5°C/10°F liquid is colder than base temperature, increase table values 4% for R410a.

Ⓣ 0.034 bar (0.5 psig) pressure drop capacities apply only to regulators with LPD (low pressure drop) Variation.

Ⓣ 20mm (3/4") regulator is available with throttling plug capacities equivalent to approximately 50% and 17% of the ratings in the tables.

Ⓣ The 32mm (1 1/4"), 40mm (1 5/8"), and 65mm - 100mm (2 1/2" - 4") are available with throttling plug capacities equivalent to approximately 35% of the ratings in the tables.

Note: For liquid overfeed applications (nominal 2:1 to 5:1 ratio), add 20% to the evaporator load and select a regulator based on this increased load value.

Suction Capacities - A4

R-507a (KW)

Evap T (°C) P (barg)	Pressure Drop (bar)	20mm [Ⓜ]	25mm	32mm [Ⓢ]	40mm [Ⓢ]	50mm	65mm [Ⓢ]	75mm [Ⓢ]	100mm [Ⓢ]	125mm	150mm	200mm
10° 7.45	0.14 0.7	15 33	21 45	36 79	69 151	102 223	144 316	206 451	279 609	413 903	743 1625	1135 2483
5° 6.28	0.14 0.7	13 29	19 41	33 71	62 136	93 202	131 285	187 408	252 550	374 815	673 1467	1028 2242
0° 5.23	0.14 0.7	12 26	17 37	30 64	56 122	84 181	118 257	169 366	228 495	338 733	608 1319	928 2016
-5° 4.30	0.14 0.7	11 24	15 33	27 57	51 110	75 162	106 230	152 328	205 443	304 656	547 1180	835 1804
-10° 3.48	0.14 0.7	10 21	14 29	24 51	45 97	67 144	95 204	136 292	184 394	272 584	489 1050	748 1605
-15° 2.76	0.14 0.7	8.7 19	12 26	21 45	40 86	60 128	85 181	121 258	164 348	242 516	436 929	667 1419
-20° 2.13	0.14 0.35	7.7 12	11 17	19 29	36 56	53 82	75 117	108 167	145 225	215 333	387 600	592 916
-25° 1.59	0.14 0.35	6.8 11	9.5 15	17 26	32 49	47 72	66 102	95 146	128 197	190 293	342 527	522 805
-30° 1.12	0.035 [Ⓢ] 0.14	3.0 6.0	4.2 8.3	7.4 15	14 28	21 41	30 58	42 83	57 112	84 167	152 300	232 458
-35° 0.71	0.035 [Ⓢ] 0.14	2.7 5.2	3.7 7.3	6.5 13	12 24	18 36	26 51	37 73	50 98	74 145	133 261	203 399
-40° 0.37	0.035 [Ⓢ] 0.14	2.3 4.5	3.2 6.3	5.6 11	11 21	16 31	22 44	32 63	43 85	64 125	115 226	176 345

R-507a (TONS)

Evap T (°F) P (psig)	Pressure Drop (psi)	¾" [Ⓜ]	1"	1¼" [Ⓢ]	1½" [Ⓢ]	2"	2½" [Ⓢ]	3" [Ⓢ]	4" [Ⓢ]	5"	6"	8"
50° 108.0	2 10	4.3 10	6.0 13	11 23	20 44	30 65	42 93	60 132	82 178	121 264	217 476	332 727
40° 89.2	2 10	3.9 8.5	5.4 12	9.5 21	18 39	27 58	38 83	54 118	73 159	108 236	195 425	298 649
30° 72.7	2 10	3.5 7.6	4.8 10	8.5 18	16 35	24 52	34 73	48 105	65 142	97 210	174 378	266 577
20° 58.3	2 10	3.1 6.7	4.3 9.3	7.5 16.2	14 31	21 46	30 65	43 93	58 125	86 185	155 334	236 510
10° 45.7	2 10	2.7 5.9	3.8 8.1	6.6 14	13 27	19 40	27 57	38 81	51 110	76 163	137 293	209 447
0° 34.8	2 5	2.4 3.7	3.3 5.2	5.8 9.1	11 17	17 26	23 36	33 52	45 70	67 104	120 186	184 285
-10° 25.5	2 5	2.1 3.2	2.9 4.5	5.1 7.9	10 15	14 22	20 32	29 45	39 61	58 90	105 162	160 248
-20° 17.6	0.5 [Ⓢ] 2	0.9 1.8	1.3 2.5	2.2 4.4	4.3 8.4	6.3 13	9.0 18	13 25	17 34	26 51	46 91	71 139
-30° 11.0	0.5 [Ⓢ] 2	0.8 1.6	1.1 2.2	1.9 3.8	3.7 7.3	5.5 11	7.8 15	11 22	15 29	22 44	40 78	61 120
-40° 5.4	0.5 [Ⓢ] 2	0.7 1.3	0.9 1.9	1.7 3.3	3.2 6.2	4.7 9.2	6.6 13	9.5 19	13 25	19 37	34 67	52 102

Capacities for R507a are based on 40°C (100°F) liquid and 5°C (10°F) superheat entering the regulator. Capacities are maximum and have no reserve for excess loads. Capacities apply to any A4A or A4W regulator (or S4A and S4W) regardless of variation used.

Sub-cooled liquid: For each 5°C/10°F liquid is colder than base temperature, increase table valves 4% for R507a.

Ⓢ 0.034 bar (0.5 psig) pressure drop capacities apply only to regulators with LPD (low pressure drop) Variation.

Ⓜ 20mm (¾") regulator is available with throttling plug capacities equivalent to approximately 50% and 17% of the ratings in the tables.

Ⓢ The 32mm (1¼"), 40mm (1½"), and 65mm - 100mm (2½" - 4") are available with throttling plug capacities equivalent to approximately 35% of the ratings in the tables.

Note: For liquid overfeed applications (nominal 2:1 to 5:1 ratio), add 20% to the evaporator load and select a regulator based on this increased load value.

Liquid Capacities - A4 (typical application: screw compressor oil feed control)

R-717 (KG/MIN & M³/HR)

Liquid Temp (°C)	Press. Drop (bar)	20mm ①		25mm		32mm ②		40mm ②		50mm		65mm ②		75mm ②		100mm ②	
		kg/min	m ³ /hr	kg/min	m ³ /hr	kg/min	m ³ /hr	kg/min	m ³ /hr	kg/min	m ³ /hr	kg/min	m ³ /hr	kg/min	m ³ /hr	kg/min	m ³ /hr
5°	0.69	68	68	95	95	165	165	314	314	466	466	658	658	941	941	1271	1271
-20°		70	70	97	97	169	169	323	323	478	478	676	676	966	966	1304	1304
-40°		71	71	99	99	172	172	329	329	487	487	688	688	984	984	1328	1328
5°	1.03	83	83	116	116	202	202	385	385	571	571	806	806	1152	1152	1556	1556
-20°		86	86	119	119	207	207	395	395	586	586	828	828	1183	1183	1597	1597
-40°		87	87	121	121	211	211	402	402	597	597	843	843	1205	1205	1627	1627
5°	1.38	96	96	134	134	233	233	445	445	659	659	931	931	1331	1331	1797	1797
-20°		99	99	137	137	239	239	456	456	676	676	956	956	1366	1366	1844	1844
-40°		101	101	140	140	244	244	465	465	689	689	973	973	1391	1391	1879	1879

R-717 (LB/MIN & GPM)

Liquid Temp (°F)	Press. Drop (psi)	3/4" ①		1"		1 1/4" ②		1 3/8" ②		2"		2 1/2" ②		3" ②		4" ②	
		lb/min	gpm	lb/min	gpm	lb/min	gpm	lb/min	gpm	lb/min	gpm	lb/min	gpm	lb/min	gpm	lb/min	gpm
40°	10	151	29	210	40	367	70	701	133	1038	197	1468	278	2098	397	2832	537
0°		155	28	215	39	376	68	717	130	1063	192	1503	272	2146	388	2898	524
-40°		158	27	219	38	383	67	732	127	1085	188	1534	266	2191	380	2958	514
40°	15	185	35	257	49	450	85	858	163	1272	241	1798	341	2569	487	3468	657
0°		189	34	263	48	460	83	878	159	1301	235	1840	333	2629	476	3549	642
-40°		193	34	268	47	470	82	896	156	1328	231	1879	326	2684	466	3623	629
40°	20	214	40	297	56	519	98	991	188	1468	278	2077	393	2966	562	4005	759
0°		219	40	304	55	531	96	1014	183	1503	272	2125	384	3036	549	4098	741
-40°		223	39	310	54	542	94	1035	180	1534	266	2169	377	3099	538	4183	726

R-22 (KG/MIN & M³/HR)

Liquid Temp (°C)	Press. Drop (bar)	20mm ①		25mm		32mm ②		40mm ②		50mm		65mm ②		75mm ②		100mm ②	
		kg/min	m ³ /hr	kg/min	m ³ /hr	kg/min	m ³ /hr	kg/min	m ³ /hr	kg/min	m ³ /hr	kg/min	m ³ /hr	kg/min	m ³ /hr	kg/min	m ³ /hr
5°	0.69	96	4.6	134	6.3	233	11	445	21	659	31	932	44	1331	63	1798	85
-20°		100	4.4	138	6.2	241	11	459	20	681	30	961	43	1374	61	1855	83
-40°		102	4.3	141	6.0	246	10	469	20	696	30	983	42	1404	60	1896	81
5°	1.03	118	5.6	164	7.8	286	14	545	26	808	38	1142	54	1632	77	2204	104
-20°		122	5.4	169	7.5	295	13	562	25	833	37	1177	52	1683	75	2272	101
-40°		125	5.3	173	7.4	301	13	575	25	852	36	1204	51	1720	73	2323	99
5°	1.38	136	6.5	189	9.0	330	16	629	30	933	44	1317	63	1883	89	2543	121
-20°		141	6.3	195	8.7	340	15	649	29	962	43	1360	61	1943	87	2624	117
-40°		144	6.1	200	8.5	348	15	664	28	984	42	1390	59	1986	85	2682	114

R-22 (LB/MIN & GPM)

Liquid Temp (°F)	Press. Drop (psi)	3/4" ①		1"		1 1/4" ②		1 3/8" ②		2"		2 1/2" ②		3" ②		4" ②	
		lb/min	gpm	lb/min	gpm	lb/min	gpm	lb/min	gpm	lb/min	gpm	lb/min	gpm	lb/min	gpm	lb/min	gpm
40°	10	214	20	297	28	519	49	991	94	1469	139	2078	197	2968	281	4007	379
0°		220	20	305	27	534	48	1020	91	1511	135	2137	191	3053	273	4121	369
-40°		225	19	313	27	547	47	1045	89	1549	132	2190	187	3128	266	4223	360
40°	15	262	25	364	34	636	60	1214	115	1799	170	2545	241	3635	344	4907	464
0°		269	24	374	33	654	59	1249	112	1851	166	2617	234	3739	334	5047	452
-40°		276	23	383	33	671	57	1280	109	1897	162	2682	228	3832	326	5173	441
40°	20	302	29	420	40	735	70	1402	133	2078	197	2938	278	4197	397	5667	536
0°		311	28	432	39	756	68	1442	129	2137	191	3022	270	4317	386	5828	521
-40°		319	27	442	38	774	66	1478	126	2190	187	3097	264	4424	377	5973	509

Capacities are based on -18°C (0°F) liquid ammonia and no flash gas.
 For evaporator temperatures between 4°C to -40°C (40°F to -40°F), capacities are within 5%.
 Correction factors for temperatures between -40°C (-40°F) and 30°C (86°F) are negligible.

- ① 20mm (3/4") regulator is available with throttling plug capacities equivalent to approximately 50% and 17% of the ratings in the tables.
- ② The 32mm (1 1/4"), 40mm (1 3/8"), and 65mm - 100mm (2 1/2" - 4") are available with throttling plug capacities equivalent to approximately 35% of the ratings in the tables.

Liquid Capacities - A4 (typical application: screw compressor oil feed control)

R-134a (KG/MIN & M³/HR)

Liquid Temp (°C)	Press. Drop (bar)	20mm ①		25mm		32mm ②		40mm ②		50mm		65mm ②		75mm ②		100mm ②	
		kg/min	m ³ /hr	kg/min	m ³ /hr	kg/min	m ³ /hr	kg/min	m ³ /hr	kg/min	m ³ /hr	kg/min	m ³ /hr	kg/min	m ³ /hr	kg/min	m ³ /hr
5°	0.69	97	4.6	134	6.3	235	11	447	21	663	31	937	44	1339	63	1808	85
-20°		100	4.4	139	6.1	242	11	461	20	683	30	966	43	1380	61	1863	82
-40°		102	4.3	142	6.0	247	10	471	20	698	30	986	42	1410	60	1904	81
5°	1.03	119	5.6	165	7.7	287	13	548	26	813	38	1148	54	1641	77	2216	104
-20°		122	5.4	170	7.5	296	13	565	25	837	37	1183	52	1690	75	2282	101
-40°		125	5.3	173	7.3	303	13	577	24	855	36	1208	51	1727	73	2332	99
5°	1.38	137	6.4	190	8.9	332	16	632	30	938	44	1325	62	1893	89	2556	120
-20°		141	6.2	196	8.7	342	15	652	29	967	43	1366	60	1951	86	2635	116
-40°		144	6.1	200	8.5	349	15	666	28	988	42	1395	59	1994	84	2692	114

R-134a (LB/MIN & GPM)

Liquid Temp (°F)	Press. Drop (psi)	¾" ①		1"		1¼" ②		1½" ②		2"		2½" ②		3" ②		4" ②	
		lb/min	gpm	lb/min	gpm	lb/min	gpm	lb/min	gpm	lb/min	gpm	lb/min	gpm	lb/min	gpm	lb/min	gpm
40°	10	215	20	298	28	522	49	997	93	1477	138	2089	196	2984	279	4028	377
0°		221	20	307	27	537	48	1024	91	1518	135	2146	190	3066	272	4139	367
-40°		226	19	314	27	550	46	1049	89	1555	131	2198	186	3141	265	4240	358
40°	15	263	25	365	34	640	60	1221	114	1809	169	2558	240	3655	342	4934	462
0°		270	24	376	33	657	58	1254	111	1859	165	2629	233	3755	333	5070	450
-40°		277	23	385	33	673	57	1285	109	1904	161	2692	228	3846	325	5193	439
40°	20	304	28	422	40	739	69	1410	132	2089	196	2954	277	4220	395	5697	533
0°		312	28	434	38	759	67	1448	128	2146	190	3035	269	4336	384	5854	519
-40°		320	27	444	38	777	66	1483	125	2198	186	3109	263	4441	375	5996	507

R-404a (KG/MIN & M³/HR)

Liquid Temp (°C)	Press. Drop (bar)	20mm ①		25mm		32mm ②		40mm ②		50mm		65mm ②		75mm ②		100mm ②	
		kg/min	m ³ /hr	kg/min	m ³ /hr	kg/min	m ³ /hr	kg/min	m ³ /hr	kg/min	m ³ /hr	kg/min	m ³ /hr	kg/min	m ³ /hr	kg/min	m ³ /hr
5°	0.69	91	4.8	126	6.7	221	12	421	22	624	33	881	47	1259	67	1700	90
-20°		95	4.7	131	6.5	229	11	437	21	648	32	916	45	1309	64	1767	87
-40°		97	4.5	135	6.3	235	11	449	21	665	31	940	44	1343	63	1814	85
5°	1.03	112	5.9	155	8.2	270	14	515	27	764	41	1079	57	1542	82	2082	111
-20°		116	5.7	161	7.9	281	14	536	26	794	39	1122	55	1603	79	2165	106
-40°		119	5.6	165	7.7	288	13	550	26	815	38	1151	54	1645	77	2222	104
5°	1.38	129	6.8	179	9.5	312	17	595	32	882	47	1246	66	1780	94	2404	128
-20°		134	6.6	186	9.1	324	16	618	30	917	45	1295	64	1851	91	2499	123
-40°		138	6.4	191	8.9	333	16	635	30	941	44	1329	62	1900	89	2565	120

R-404a (LB/MIN & GPM)

Liquid Temp (°F)	Press. Drop (psi)	¾" ①		1"		1¼" ②		1½" ②		2"		2½" ②		3" ②		4" ②	
		lb/min	gpm	lb/min	gpm	lb/min	gpm	lb/min	gpm	lb/min	gpm	lb/min	gpm	lb/min	gpm	lb/min	gpm
40°	10	202	21	281	30	491	52	938	99	1390	147	1965	208	2807	297	3790	401
0°		209	21	291	29	509	50	971	96	1439	142	2034	201	2906	287	3924	387
-40°		215	20	299	28	524	49	999	93	1481	138	2095	195	2992	279	4039	376
40°	15	248	26	344	36	602	64	1148	121	1702	180	2407	255	3438	364	4642	491
0°		256	25	356	35	623	61	1189	117	1762	174	2492	246	3560	351	4805	474
-40°		264	25	366	34	641	60	1224	114	1814	169	2565	239	3665	341	4947	461
40°	20	286	30	397	42	695	73	1326	140	1965	208	2779	294	3970	420	5360	567
0°		296	29	411	41	719	71	1373	135	2035	201	2877	284	4110	406	5549	548
-40°		305	28	423	39	741	69	1413	132	2095	195	2962	276	4232	394	5713	532

Capacities are based on -18°C (0°F) liquid ammonia and no flash gas.
 For evaporator temperatures between 4°C to -40°C (40°F to -40°F), capacities are within 5%.
 Correction factors for temperatures between -40°C (-40°F) and 30°C (86°F) are negligible.

① 20mm (¾") regulator is available with throttling plug capacities equivalent to approximately 50% and 17% of the ratings in the tables.
 ② The 32mm (1¼"), 40mm (1½"), and 65mm - 100mm (2½" - 4") are available with throttling plug capacities equivalent to approximately 35% of the ratings in the tables.

Liquid Capacities - A4 (typical application: screw compressor oil feed control)

R-410a (KG/MIN & M³/HR)

Liquid Temp (°C)	Press. Drop (bar)	20mm ①		25mm		32mm ②		40mm ②		50mm		65mm ②		75mm ②		100mm ②	
		kg/min	m ³ /hr	kg/min	m ³ /hr	kg/min	m ³ /hr	kg/min	m ³ /hr	kg/min	m ³ /hr	kg/min	m ³ /hr	kg/min	m ³ /hr	kg/min	m ³ /hr
5°	0.69	92	4.8	128	6.7	222	12	424	22	629	33	888	46	1269	66	1714	89
-20°		96	4.6	133	6.4	232	11	441	21	654	32	924	45	1321	64	1784	86
-40°		98	4.5	136	6.2	238	11	453	21	672	31	949	43	1357	62	1832	84
5°	1.03	113	5.9	156	8.2	272	14	519	27	770	40	1088	57	1555	81	2100	110
-20°		117	5.6	163	7.8	284	14	541	26	801	39	1132	55	1618	78	2185	105
-40°		120	5.5	167	7.6	291	13	555	25	823	38	1163	53	1662	76	2244	103
5°	1.38	130	6.8	180	9.4	315	16	600	31	889	46	1256	66	1795	94	2424	127
-20°		135	6.5	188	9.0	327	16	624	30	925	45	1307	63	1868	90	2523	122
-40°		139	6.4	193	8.8	336	15	641	29	950	43	1343	61	1919	88	2591	118

R-410a (LB/MIN & GPM)

Liquid Temp (°F)	Press. Drop (psi)	3/4" ①		1"		1 1/4" ②		1 3/8" ②		2"		2 1/2" ②		3" ②		4" ②	
		lb/min	gpm	lb/min	gpm	lb/min	gpm	lb/min	gpm	lb/min	gpm	lb/min	gpm	lb/min	gpm	lb/min	gpm
40°	10	204	21	283	29	495	52	946	98	1401	146	1982	206	2831	294	3822	398
0°		211	20	293	28	513	50	980	95	1452	141	2054	199	2934	284	3961	384
-40°		218	20	302	28	529	48	1009	92	1496	137	2116	193	3022	276	4080	372
40°	15	250	26	347	36	607	63	1158	120	1716	179	2427	252	3467	361	4681	487
0°		259	25	359	35	629	61	1200	116	1779	172	2515	244	3593	348	4851	470
-40°		267	24	370	34	648	59	1236	113	1832	167	2591	236	3702	338	4997	456
40°	20	288	30	400	42	701	73	1337	139	1982	206	2802	292	4003	416	5405	562
0°		299	29	415	40	726	70	1386	134	2054	199	2904	281	4149	402	5601	542
-40°		308	28	427	39	748	68	1428	130	2116	193	2992	273	4274	390	5770	527

R-507a (KG/MIN & M³/HR)

Liquid Temp (°C)	Press. Drop (bar)	20mm ①		25mm		32mm ②		40mm ②		50mm		65mm ②		75mm ②		100mm ②	
		kg/min	m ³ /hr	kg/min	m ³ /hr	kg/min	m ³ /hr	kg/min	m ³ /hr	kg/min	m ³ /hr	kg/min	m ³ /hr	kg/min	m ³ /hr	kg/min	m ³ /hr
5°	0.69	91	4.8	127	6.7	221	12	422	22	625	33	883	47	1262	67	1705	90
-20°		95	4.6	132	6.4	230	11	439	21	650	32	919	45	1313	64	1773	87
-40°		98	4.5	135	6.3	236	11	450	21	668	31	943	44	1348	62	1820	84
5°	1.03	112	5.9	155	8.2	271	14	516	27	766	40	1082	57	1546	82	2088	110
-20°		116	5.7	162	7.9	282	14	537	26	796	39	1125	55	1608	78	2171	106
-40°		120	5.5	166	7.7	289	13	551	26	818	38	1155	53	1651	76	2229	103
5°	1.38	129	6.8	179	9.5	313	17	596	31	884	47	1249	66	1785	94	2411	127
-20°		134	6.6	187	9.1	325	16	620	30	920	45	1299	63	1857	91	2507	122
-40°		138	6.4	191	8.9	334	15	637	29	944	44	1334	62	1906	88	2574	119

R-507a (LB/MIN & GPM)

Liquid Temp (°F)	Press. Drop (psi)	3/4" ①		1"		1 1/4" ②		1 3/8" ②		2"		2 1/2" ②		3" ②		4" ②	
		lb/min	gpm	lb/min	gpm	lb/min	gpm	lb/min	gpm	lb/min	gpm	lb/min	gpm	lb/min	gpm	lb/min	gpm
40°	10	203	21	281	30	493	52	940	99	1393	147	1970	207	2815	296	3800	400
0°		210	21	292	29	510	50	974	96	1443	142	2041	200	2915	286	3936	386
-40°		216	20	300	28	525	49	1003	93	1486	137	2102	194	3002	278	4053	375
40°	15	248	26	345	36	603	63	1151	121	1706	180	2413	254	3447	363	4654	490
0°		257	25	357	35	625	61	1193	117	1767	173	2499	245	3571	350	4820	473
-40°		265	24	368	34	643	60	1228	114	1820	168	2574	238	3677	340	4964	459
40°	20	287	30	398	42	697	73	1329	140	1970	207	2786	293	3980	419	5374	565
0°		297	29	412	40	722	71	1377	135	2041	200	2886	283	4123	404	5566	546
-40°		306	28	425	39	743	69	1418	131	2102	194	2972	275	4246	393	5732	530

Capacities are based on -18°C (0°F) liquid ammonia and no flash gas.
 For evaporator temperatures between 4°C to -40°C (40°F to -40°F), capacities are within 5%.
 Correction factors for temperatures between -40°C (-40°F) and 30°C (86°F) are negligible.

- ① 20mm (3/4") regulator is available with throttling plug capacities equivalent to approximately 50% and 17% of the ratings in the tables.
- ② The 32mm (1 1/4"), 40mm (1 3/8"), and 65mm - 100mm (2 1/2" - 4") are available with throttling plug capacities equivalent to approximately 35% of the ratings in the tables.

Oil Capacities - A4 (typical application: screw compressor oil feed control)

300 SSU Viscosity (M³/HR)

For 30°C to 50°C Oil ①			
Port Size (mm)	Pressure Drop		
	0.3 bar	0.7 bar	3.0 bar
20	3.9	5.4	12
25	5.4	7.5	17
32	9.3	13	30
40	18	25	57
50	27	36	84
65	39	52	120
75	54	75	170

300 SSU Viscosity (GPM)

For 85°F to 120°F Oil ①			
Port Size (inch)	Pressure Drop		
	5.0 psi	10 psi	50 psi
¾	17	24	54
1	24	33	74
1¼	41	58	130
1⅝	79	110	250
2	120	160	370
2½	170	230	520
3	240	330	750

① Based on no foaming of oil through regulator.

Hot Gas Bypass Capacities - A4A0

(typical application: screw compressor oil feed control)

R-717 (KW)

Inlet Pressure	Outlet Pressure Range	Port Size						
		20mm [Ⓢ]	25mm	32mm	40mm	50mm	65mm	75mm
2.1 barg	0 - 45 cm Hg	120	160	290	550	810	1100	1600
10.3 barg	3.1 bar to 45 cm Hg	380	530	930	1800	2600	3700	5300

R-717 (TONS)

Inlet Pressure	Outlet Pressure Range	Port Size						
		³ / ₄ " [Ⓢ]	1"	1 ¹ / ₄ "	1 ⁵ / ₈ "	2"	2 ¹ / ₂ "	3"
30 psig	0 - 15 in Hg	34	47	82	160	230	330	470
150 psig	45 psi to 15 in Hg	110	150	270	510	760	1100	1500

Based on near saturated inlet gas and 11 bar (150 psig) ratings for 30°C (86°F) condensing, 2 bar (30 psig) ratings for -7°C (20°F) condensing. Correction no essential for other gas or liquid temperatures.

Ⓢ For capacities of larger regulators or other conditions, contact factory. Flow coefficients for all sizes are shown on page 5 and may be used for other flow calculation and for larger regulators.

R-22 (KW)

Condensing Temp (°C)	Discharge Temp (°C)	Port Size						
		20mm [Ⓢ]	25mm	32mm	40mm	50mm	65mm	75mm
30	80	120	200	350	570	1000	1400	1900
40	80	140	240	400	660	1200	1600	2200
45	80	160	260	440	720	1300	1700	2400
50	80	170	280	480	780	1400	1900	2600

R-22 (TONS)

Condensing Temp (°F)	Discharge Temp (°F)	Port Size						
		³ / ₄ " [Ⓢ]	1"	1 ¹ / ₄ "	1 ⁵ / ₈ "	2"	2 ¹ / ₂ "	3"
86	180	35	58	99	160	290	380	550
100	180	41	67	110	190	330	440	630
110	180	44	73	130	200	370	480	690
120	180	48	79	140	220	400	530	750

Capacities are average for the condensing temperatures and the corresponding discharge temperatures listed. Liquid temperature is the same as condensing temperature; evaporator temperature 5°C (40°F) or less. Use at other reasonable conditions usually requires no capacity correction.

Ⓢ The 20mm (³/₄" port size type A4A0 regulator is available with reduced throttling plug capacities equivalent to approximately 50% to 17% of the rating shown here.

Compact Pressure Regulators - A2

The A2 type pressure regulators are compact, direct diaphragm operated, for use with refrigerant liquid or vapor. The regulators are for use in systems where a small inlet or outlet pressure regulator is needed.

Specifications

Body Gray Iron (ASTM A126 Class B)
 Temperature Range -45°C to 105°C (-50°F to 220°F)
 Maximum Rated Pressure (MRP) 27.6 barg (400 psig)

DIN Specifications

Body Ductile Iron (DIN GGG 40.3)
 Temperature Range -45°C to 105°C (-50°F to 220°F)
 Maximum Rated Pressure (MRP) 28 barg (406 psig)

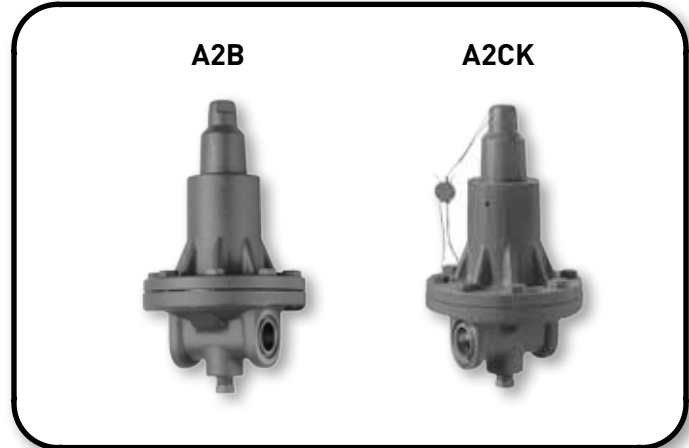

General Information

Type	Description	Flow Coefficient		Ranges Available ③	Connections Available ③	
		Kv	Cv		FPT, SW, WN	DIN Weld Neck
A2B	Small Capacity Back Pressure Regulator	0.43	0.5	V, A, D	1/4", 3/8", 1/2", 3/4"	13, 20
A2BK ①	Relief, Give pressure setting	0.34	0.4	A, D		
A2BP	Differential Regulator for ext. connection	0.43	0.5	A, D		
A2BM	Electrically Compensated	0.43	0.5	V, A, D		
A2A	Small Capacity Back Pressure Regulator	1.28	1.5	A, D	1/4", 3/8", 1/2", 3/4"	13, 20
A2BO1 ②	Small Capacity Outlet Pressure Regulator	0.09	0.1	V, D	1/4", 3/8", 1/2", 3/4"	13, 20
A2BO2 ②		0.17	0.2			
A2BO4 ②		0.43	0.5			
A2CK	Relief Regulator – Liquid Lines	0.97	1.14	D	1/4", 3/8", 1/2", 3/4"	13, 20

① The A2BK re-seating relief regulator can be used for various relief to low side applications including cold liquid line sections where buildup of dangerous hydrostatic pressure is possible. See "Safe Operation" on the back cover.

② Specify for external pressure connection.

③ Bold face type is standard size. FPT will be furnished unless specified otherwise.

Pressure Setting Ranges

Code	Set Point Range	Approx. Pressure Change per Turn of Adjustment Screw	Factory Set Point (unless other wise specified)
A ①	0.35 to 10 barg (5 to 150 psig)	1.7 barg (25 psig)	2.8 barg (40 psig)
V	500mm Hg to 8.3 barg (20 in Hg to 120 psig)	1.7 barg (25 psig)	1.0 barg (15 psig)
D	5.2 to 19.3 barg (75 to 280 psig)	3.7 barg (53 psig)	9.7 barg (140 psig)

① Standard

For variations "K" and "BK", the set point is factory set and sealed. Standard set point for each range is shown in the table above. A custom setting may be specified by adding the set point in PSIG preceded by "-" at the end of the model number. Set point must be valid for the range selected.

Application Guide

Type	Function	Operation	Typical Applications
A2B	Control inlet pressure	Regulate at preset inlet pressure	1. Small capacity back pressure regulator 2. Small capacity defrost relief regulator
A2A	Inlet regulator, greater capacity	Filed adjustable Open on rise in inlet pressure	
A2BO	Control outlet pressure	Regulate at preset outlet pressure Filed adjustable Open on drop in outlet pressure	1. Gas pressure reducing regulator 2. Liquid or oil pressure reducing regulator
A2CK ①	Relief Regulator	Regulate inlet pressure. Factory set	1. Prevent hydrostatic pressure build-up in isolated sections of liquid lines.

① The design of the A2CK valve allows for higher flow and a "quick release" feature. However, it does not offer the same type of controlled response which may be required for a standard regulator application. For those applications where a small regulator is needed for accurate upstream pressure control, and A2A or A2B direct operated regulator should be considered.

Compact Pressure Regulators - A2B, S6N

Function

One main regulator can be controlled by combinations of remote regulators and solenoids to provide a variety of functions. Because of the high cost of installation and the possibility of error in field remote piping, the A4A Series of self-contained regulators is preferred (see pages 5 - 9).

Applications

- Typical applications include:
- **Main regulator in an inaccessible location.** Pilot can be located where it can be adjusted and serviced conveniently.
 - **When better environment is required.** Remote pilots can solve electrical or pneumatic variation problems.

Typical Remote Combinations

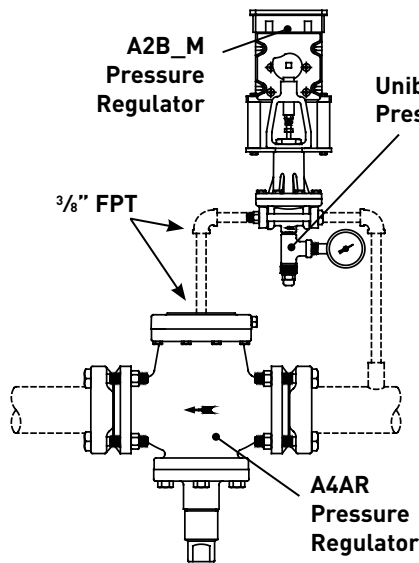

Figure 1: The remote equivalent to a 75mm (3") Type A4AM would use a 75mm (3") A4AR main valve with a A2BM pilot regulator.

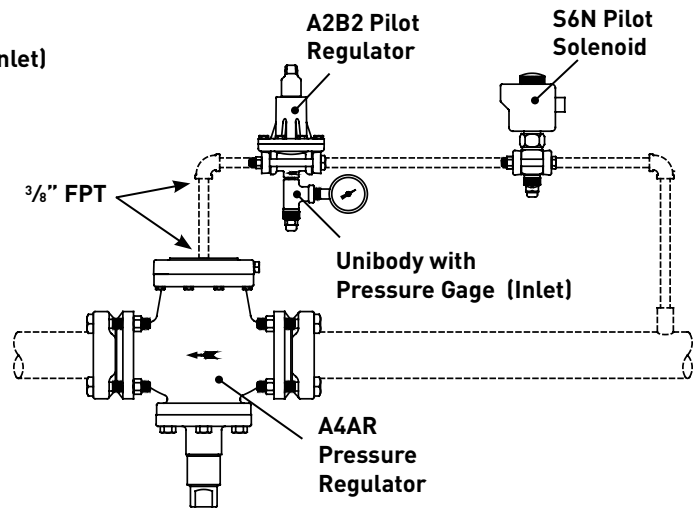

Figure 2: The remote equivalent to a 50mm (2") Type A4AS would use a 50mm (2") A4AR main valve with a A2B2 pilot regulator with an S6N pilot solenoid piped in series.

Any of the A4A or A4W regulators with or without added variations are available as a remote regulator by using an A4AR 20mm - 100mm (3/4" - 4") or A4WR 125mm - 200mm (5" - 8") main valve with the suitable pilots.

Type	Description	For use with Main Valve Size and Type	Ranges Available ①	Connections Available ①
				FPT, SW, WN
A2B2	Inlet Pressure Pilot Regulator	20mm - 50mm (3/4" - 2") A4AR	V, A, D	3/8", 1/2", 3/4"
A2B	Inlet Pressure Pilot Regulator	65mm - 100mm (2 1/2" - 4") A4AR 125mm - 200mm (5" - 8") A4WR		
A2BO2E	Outlet Pressure Pilot Regulator	20mm - 50mm (3/4" - 2") A4AR	V, D	3/8", 1/2", 3/4"
A2BO4E	Outlet Pressure Pilot Regulator	65mm - 100mm (2 1/2" - 4") A4AR 125mm - 200mm (5" - 8") A4WR		

① Bold face type is standard size. FPT will be furnished unless specified otherwise. All of the Pilot Regulators above are available as compensated controls. For Electrically Compensated, add suffix "M", as A2B2M; for Pneumatically Compensated, add suffix "P" or "3P", as A2B2P or A2B23P; for Temperature Compensated, add suffix "T", as A2BT. Temperature range and scale is - 30°C to 30°C (-20°F to 80°F).

Suction Capacities - A2

R-717 (KW)

Evap T (°C) P (bar)	Pressure Drop (bar)	A2B	A2BK	A2BP	A2A	A2BO1	A2BO2	A2BO4	A2CK
10° 5.14	0.14 0.34 0.69	3.50 5.47 7.60	2.80 4.38 6.08	3.50 5.47 7.60	10.49 16.42 22.8	0.70 1.09 1.52	1.40 2.19 3.04	3.50 5.47 7.60	16.0 25.1 34.9
5° 4.14	0.14 0.34 0.69	3.20 5.00 6.92	2.56 4.00 5.53	3.20 5.00 6.92	9.59 14.99 20.7	0.64 1.00 1.38	1.28 2.00 2.77	3.20 5.00 6.92	14.7 22.9 31.8
0° 3.28	0.14 0.34 0.69	2.91 4.54 6.25	2.33 3.63 5.00	2.91 4.54 6.25	8.74 13.62 18.7	0.58 0.91 1.25	1.16 1.82 2.50	2.91 4.54 6.25	13.4 20.8 28.7
-5° 2.53	0.14 0.34 0.69	2.64 4.11 5.62	2.11 3.29 4.50	2.64 4.11 5.62	7.93 12.32 16.8	0.53 0.82 1.12	1.06 1.64 2.25	2.64 4.11 5.62	12.1 18.8 25.8
-10° 1.89	0.14 0.34 0.69	2.39 3.69 5.01	1.91 2.96 4.01	2.39 3.69 5.01	7.16 11.08 15.0	0.48 0.74 1.00	0.95 1.48 2.00	2.39 3.69 5.01	10.9 16.9 23.0
-15° 1.35	0.14 0.34	2.15 3.30	1.72 2.64	2.15 3.30	6.44 9.91	0.43 0.66	0.86 1.32	2.15 3.30	9.87 15.1
-20° 0.89	0.14 0.34	1.92 2.93	1.53 2.34	1.92 2.93	5.75 8.79	0.38 0.59	0.77 1.17	1.92 2.93	8.82 13.4
-25° 0.50	0.14 0.34	1.70 2.57	1.36 2.06	1.70 2.57	5.11 7.72	0.34 0.51	0.68 1.03	1.70 2.57	7.84 11.8
-30° 0.18	0.14 0.34	1.50 2.23	1.20 1.79	1.50 2.23	4.51 6.70	0.30 0.45	0.60 0.89	1.50 2.23	6.92 10.2
-35° <i>-0.08</i>	0.14 0.34	1.32 1.90	1.05 1.52	1.32 1.90	3.95 5.71	0.26 0.38	0.53 0.76	1.32 1.90	6.05 8.75
-40° <i>-0.30</i>	0.14 0.34	1.14 1.57	0.91 1.26	1.14 1.57	3.42 4.71	0.23 0.31	0.46 0.63	1.14 1.57	5.24 7.23

Capacities for R717 are based on 30°C liquid. Capacities are maximum and have no reserve for excess loads. Capacities apply to any A4A or A4W regulator (or S4A and S4W) regardless of variation used.

Sub-cooled liquid: For each 5°C/10°F liquid is colder than base temperature, increase table valves 3% for R717.

Note: For liquid overfeed applications (nominal 2:1 to 5:1 ratio), add 20% to the evaporator load and select a regulator based on this increased load value.

R-717 (TONS)

Evap T (°F) P (psig)	Press Drop (psi)	A2B	A2BK	A2BP	A2A	A2BO1	A2BO2	A2BO4	A2CK
50° 74.5	2 5 10	0.99 1.56 2.16	0.80 1.24 1.73	0.99 1.56 2.16	2.98 4.67 6.49	0.20 0.31 0.43	0.40 0.62 0.86	0.99 1.56 2.16	4.57 7.16 9.95
40° 58.6	2 5 10	0.90 1.41 1.95	0.72 1.12 1.56	0.90 1.41 1.95	2.70 4.22 5.84	0.18 0.28 0.39	0.36 0.56 0.78	0.90 1.41 1.95	4.14 6.47 8.95
30° 45.0	2 5 10	0.81 1.26 1.74	0.65 1.01 1.39	0.81 1.26 1.74	2.43 3.79 5.21	0.16 0.25 0.35	0.32 0.51 0.70	0.81 1.26 1.74	3.73 5.81 7.99
20° 33.5	2 5 10	0.73 1.13 1.54	0.58 0.90 1.23	0.73 1.13 1.54	2.18 3.38 4.62	0.15 0.23 0.31	0.29 0.45 0.62	0.73 1.13 1.54	3.34 5.19 7.08
10° 23.8	2 5 10	0.65 1.00 1.35	0.52 0.80 1.08	0.65 1.00 1.35	1.94 3.00 4.05	0.13 0.20 0.27	0.26 0.40 0.54	0.65 1.00 1.35	2.98 4.60 6.21
0° 15.7	2 5	0.57 0.88	0.46 0.70	0.57 0.88	1.72 2.64	0.11 0.18	0.23 0.35	0.57 0.88	2.64 4.05
-10° 9.0	2 5	0.50 0.77	0.40 0.61	0.50 0.77	1.51 2.30	0.10 0.15	0.20 0.31	0.50 0.77	2.32 3.52
-20° 3.6	2 5	0.44 0.66	0.35 0.53	0.44 0.66	1.32 1.97	0.09 0.13	0.18 0.26	0.44 0.66	2.02 3.02
-30° <i>1.6 in Hg</i>	2 5	0.38 0.55	0.30 0.44	0.38 0.55	1.14 1.65	0.08 0.11	0.15 0.22	0.38 0.55	1.75 2.54
-40° <i>8.8 in Hg</i>	2 5	0.32 0.45	0.26 0.36	0.32 0.45	0.97 1.34	0.06 0.09	0.13 0.18	0.32 0.45	1.49 2.06

Suction Capacities - A2

R-22 (KW)

Evap T (°C) P (barg)	Pressure Drop (bar)	A2B	A2BK	A2BP	A2A	A2BO1	A2BO2	A2BO4	A2CK
10° 5.80	0.14 0.34	1.03 1.62	0.83 1.30	1.03 1.62	3.10 4.86	0.21 0.32	0.41 0.65	1.03 1.62	4.75 7.45
5° 4.83	0.14 0.34	0.95 1.48	0.76 1.19	0.95 1.48	2.84 4.45	0.19 0.30	0.38 0.59	0.95 1.48	4.36 6.82
0° 3.97	0.14 0.34	0.87 1.35	0.69 1.08	0.87 1.35	2.60 4.06	0.17 0.27	0.35 0.54	0.87 1.35	3.98 6.22
-5° 3.20	0.14 0.34	0.79 1.23	0.63 0.98	0.79 1.23	2.37 3.68	0.16 0.25	0.32 0.49	0.79 1.23	3.63 5.65
-10° 2.53	0.14 0.34	0.72 1.11	0.57 0.89	0.72 1.11	2.15 3.33	0.14 0.22	0.29 0.44	0.72 1.11	3.29 5.11
-15° 1.95	0.14 0.34	0.65 1.00	0.52 0.80	0.65 1.00	1.94 3.00	0.13 0.20	0.26 0.40	0.65 1.00	2.97 4.60
-20° 1.44	0.14 0.34	0.58 0.89	0.46 0.72	0.58 0.89	1.74 2.68	0.12 0.18	0.23 0.36	0.58 0.89	2.67 4.12
-25° 1.00	0.14 0.34	0.52 0.80	0.42 0.64	0.52 0.80	1.56 2.39	0.10 0.16	0.21 0.32	0.52 0.80	2.39 3.66
-30° 0.63	0.14 0.34	0.46 0.70	0.37 0.56	0.46 0.70	1.39 2.10	0.09 0.14	0.18 0.28	0.46 0.70	2.13 3.23
-35° 0.31	0.14 0.34	0.41 0.61	0.33 0.49	0.41 0.61	1.23 1.84	0.08 0.12	0.16 0.24	0.41 0.61	1.88 2.81
-40° 0.04	0.14 0.34	0.36 0.53	0.29 0.42	0.36 0.53	1.08 1.58	0.07 0.11	0.14 0.21	0.36 0.53	1.65 2.42

R-22 (TONS)

Evap T (°F) P (psig)	Pressure Drop (psi)	A2B	A2BK	A2BP	A2A	A2BO1	A2BO2	A2BO4	A2CK
50° 84.1	2 5	0.35 0.55	0.28 0.44	0.35 0.55	1.05 1.65	0.07 0.11	0.14 0.22	0.35 0.55	1.61 2.52
40° 68.6	2 5	0.32 0.50	0.25 0.40	0.32 0.50	0.95 1.49	0.06 0.10	0.13 0.20	0.32 0.50	1.46 2.29
30° 55.0	2 5	0.29 0.45	0.23 0.36	0.29 0.45	0.86 1.35	0.06 0.09	0.11 0.18	0.29 0.45	1.32 2.06
20° 43.1	2 5	0.26 0.40	0.21 0.32	0.26 0.40	0.78 1.21	0.05 0.08	0.10 0.16	0.26 0.40	1.19 1.85
10° 32.8	2 5	0.23 0.36	0.19 0.29	0.23 0.36	0.70 1.08	0.05 0.07	0.09 0.14	0.23 0.36	1.07 1.65
0° 24.0	2 5	0.21 0.32	0.17 0.26	0.21 0.32	0.62 0.96	0.04 0.06	0.08 0.13	0.21 0.32	0.95 1.47
-10° 16.5	2 5	0.18 0.28	0.15 0.22	0.18 0.28	0.55 0.84	0.04 0.06	0.07 0.11	0.18 0.28	0.84 1.29
-20° 10.2	2 5	0.16 0.24	0.13 0.20	0.16 0.24	0.48 0.73	0.03 0.05	0.06 0.10	0.16 0.24	0.74 1.13
-30° 4.9	2 5	0.14 0.21	0.11 0.17	0.14 0.21	0.42 0.63	0.03 0.04	0.06 0.08	0.14 0.21	0.65 0.97
-40° 0.6	2 5	0.12 0.18	0.10 0.14	0.12 0.18	0.37 0.54	0.02 0.04	0.05 0.07	0.12 0.18	0.56 0.82

Capacities for R22 are based on 40°C (100°F) liquid and 5°C (10°F) superheat entering the regulator. Capacities are maximum and have no reserve for excess loads. Capacities apply to any A4A or A4W regulator (or S4A and S4W) regardless of variation used.

Sub-cooled liquid: For each 5°C/10°F liquid is colder than base temperature, increase table values 4% for R22.

Note: For liquid overfeed applications (nominal 2:1 to 5:1 ratio), add 20% to the evaporator load and select a regulator based on this increased load value.

Suction Capacities - A2

R-134a (KW)

Evap T (°C) P (barg)	Pressure Drop (bar)	A2B	A2BK	A2BP	A2A	A2BO1	A2BO2	A2BO4	A2CK
10° 3.13	0.14 0.34	0.81 1.26	0.65 1.01	0.81 1.26	2.43 3.78	0.16 0.25	0.32 0.50	0.81 1.26	3.72 5.80
5° 2.48	0.14 0.34	0.73 1.13	0.58 0.91	0.73 1.13	2.19 3.40	0.15 0.23	0.29 0.45	0.73 1.13	3.36 5.21
0° 1.91	0.14 0.34	0.65 1.01	0.52 0.81	0.65 1.01	1.96 3.04	0.13 0.20	0.26 0.41	0.65 1.01	3.01 4.66
-5° 1.42	0.14 0.34	0.59 0.90	0.47 0.72	0.59 0.90	1.76 2.70	0.12 0.18	0.23 0.36	0.59 0.90	2.69 4.14
-10° 0.99	0.14 0.34	0.52 0.80	0.42 0.64	0.52 0.80	1.56 2.39	0.10 0.16	0.21 0.32	0.52 0.80	2.39 3.66
-15° 0.63	0.14 0.34	0.46 0.70	0.37 0.56	0.46 0.70	1.38 2.09	0.09 0.14	0.18 0.28	0.46 0.70	2.12 3.21
-20° 0.31	0.14 0.34	0.40 0.61	0.32 0.48	0.40 0.61	1.21 1.82	0.08 0.12	0.16 0.24	0.40 0.61	1.86 2.79
-25° 0.05	0.14 0.34	0.35 0.52	0.28 0.41	0.35 0.52	1.06 1.56	0.07 0.10	0.14 0.21	0.35 0.52	1.62 2.38
-30° <i>-0.17</i>	0.14 0.34	0.31 0.44	0.24 0.35	0.31 0.44	0.92 1.31	0.06 0.09	0.12 0.17	0.31 0.44	1.41 2.00
-35° <i>-0.35</i>	0.14 0.34	0.26 0.35	0.21 0.28	0.26 0.35	0.78 1.06	0.05 0.07	0.10 0.14	0.26 0.35	1.20 1.62
-40° <i>-0.50</i>	0.14 0.34	0.22 0.27	0.18 0.21	0.22 0.27	0.66 0.80	0.04 0.05	0.09 0.11	0.22 0.27	1.02 1.22

R-134a (TONS)

Evap T (°F) P (psig)	Pressure Drop (psi)	A2B	A2BK	A2BP	A2A	A2BO1	A2BO2	A2BO4	A2CK
50° 45.4	2 5	0.28 0.43	0.22 0.34	0.28 0.43	0.83 1.29	0.06 0.09	0.11 0.17	0.28 0.43	1.27 1.97
40° 35.0	2 5	0.25 0.38	0.20 0.30	0.25 0.38	0.74 1.14	0.05 0.08	0.10 0.15	0.25 0.38	1.13 1.75
30° 26.1	2 5	0.22 0.34	0.17 0.27	0.22 0.34	0.65 1.01	0.04 0.07	0.09 0.13	0.22 0.34	1.00 1.55
20° 18.4	2 5	0.19 0.29	0.15 0.24	0.19 0.29	0.58 0.88	0.04 0.06	0.08 0.12	0.19 0.29	0.88 1.36
10° 11.9	2 5	0.17 0.26	0.13 0.21	0.17 0.26	0.50 0.77	0.03 0.05	0.07 0.10	0.17 0.26	0.77 1.18
0° 6.5	2 5	0.15 0.22	0.12 0.18	0.15 0.22	0.44 0.66	0.03 0.04	0.06 0.09	0.15 0.22	0.67 1.01
-10° 1.9	2 5	0.13 0.19	0.10 0.15	0.13 0.19	0.38 0.56	0.03 0.04	0.05 0.07	0.13 0.19	0.58 0.86
-20° <i>3.7 in Hg</i>	2 5	0.11 0.15	0.09 0.12	0.11 0.15	0.32 0.46	0.02 0.03	0.04 0.06	0.11 0.15	0.50 0.71
-30° <i>9.8 in Hg</i>	2 5	0.09 0.12	0.07 0.10	0.09 0.12	0.27 0.37	0.02 0.02	0.04 0.05	0.09 0.12	0.42 0.57
-40° <i>14.8 in Hg</i>	2 5	0.08 0.09	0.06 0.07	0.08 0.09	0.23 0.27	0.02 0.02	0.03 0.04	0.08 0.09	0.35 0.42

Capacities for R134a are based on 40°C (100°F) liquid and 5°C (10°F) superheat entering the regulator. Capacities are maximum and have no reserve for excess loads. Capacities apply to any A4A or A4W regulator (or S4A and S4W) regardless of variation used.

Sub-cooled liquid: For each 5°C/10°F liquid is colder than base temperature, increase table values 4% for R134a.

Note: For liquid overfeed applications (nominal 2:1 to 5:1 ratio), add 20% to the evaporator load and select a regulator based on this increased load value.

Suction Capacities - A2

R-404a (KW)

Evap T (°C) P (barg)	Pressure Drop (bar)	A2B	A2BK	A2BP	A2A	A2BO1	A2BO2	A2BO4	A2CK
10° 7.26	0.14 0.34	0.89 1.39	0.71 1.11	0.89 1.39	2.66 4.17	0.18 0.28	0.35 0.56	0.89 1.39	4.08 6.39
5° 6.11	0.14 0.34	0.80 1.26	0.64 1.01	0.80 1.26	2.41 3.78	0.16 0.25	0.32 0.50	0.80 1.26	3.70 5.79
0° 5.09	0.14 0.34	0.73 1.13	0.58 0.91	0.73 1.13	2.18 3.40	0.15 0.23	0.29 0.45	0.73 1.13	3.34 5.22
-5° 4.18	0.14 0.34	0.65 1.02	0.52 0.82	0.65 1.02	1.96 3.06	0.13 0.20	0.26 0.41	0.65 1.02	3.00 4.69
-10° 3.38	0.14 0.34	0.59 0.91	0.47 0.73	0.59 0.91	1.76 2.73	0.12 0.18	0.23 0.36	0.59 0.91	2.69 4.19
-15° 2.67	0.14 0.34	0.52 0.81	0.42 0.65	0.52 0.81	1.57 2.43	0.10 0.16	0.21 0.32	0.52 0.81	2.40 3.73
-20° 2.06	0.14 0.34	0.46 0.72	0.37 0.57	0.46 0.72	1.39 2.15	0.09 0.14	0.19 0.29	0.46 0.72	2.13 3.30
-25° 1.52	0.14 0.34	0.41 0.63	0.33 0.50	0.41 0.63	1.23 1.89	0.08 0.13	0.16 0.25	0.41 0.63	1.88 2.90
-30° 1.06	0.14 0.34	0.36 0.55	0.29 0.44	0.36 0.55	1.08 1.65	0.07 0.11	0.14 0.22	0.36 0.55	1.65 2.53
-35° 0.67	0.14 0.34	0.31 0.48	0.25 0.38	0.31 0.48	0.94 1.43	0.06 0.10	0.13 0.19	0.31 0.48	1.44 2.19
-40° 0.34	0.14 0.34	0.27 0.41	0.22 0.33	0.27 0.41	0.81 1.22	0.05 0.08	0.11 0.16	0.27 0.41	1.25 1.87

R-404a (TONS)

Evap T (°F) P (psig)	Pressure Drop (psi)	A2B	A2BK	A2BP	A2A	A2BO1	A2BO2	A2BO4	A2CK
50° 105.3	2 5	0.30 0.48	0.24 0.38	0.30 0.48	0.91 1.43	0.06 0.10	0.12 0.19	0.30 0.48	1.40 2.20
40° 86.9	2 5	0.27 0.43	0.22 0.34	0.27 0.43	0.82 1.29	0.05 0.09	0.11 0.17	0.27 0.43	1.26 1.97
30° 70.7	2 5	0.24 0.38	0.20 0.31	0.24 0.38	0.73 1.15	0.05 0.08	0.10 0.15	0.24 0.38	1.12 1.76
20° 56.6	2 5	0.22 0.34	0.17 0.27	0.22 0.34	0.65 1.02	0.04 0.07	0.09 0.14	0.22 0.34	1.00 1.56
10° 44.3	2 5	0.19 0.30	0.15 0.24	0.19 0.30	0.58 0.90	0.04 0.06	0.08 0.12	0.19 0.30	0.88 1.38
0° 33.7	2 5	0.17 0.26	0.14 0.21	0.17 0.26	0.51 0.79	0.03 0.05	0.07 0.10	0.17 0.26	0.78 1.21
-10° 24.6	2 5	0.15 0.23	0.12 0.18	0.15 0.23	0.44 0.68	0.03 0.05	0.06 0.09	0.15 0.23	0.68 1.05
-20° 16.8	2 5	0.13 0.20	0.10 0.16	0.13 0.20	0.38 0.59	0.03 0.04	0.05 0.08	0.13 0.20	0.59 0.90
-30° 10.3	2 5	0.11 0.17	0.09 0.13	0.11 0.17	0.33 0.50	0.02 0.03	0.04 0.07	0.11 0.17	0.51 0.77
-40° 4.9	2 5	0.09 0.14	0.08 0.11	0.09 0.14	0.28 0.42	0.02 0.03	0.04 0.06	0.09 0.14	0.43 0.65

Capacities for R404a are based on 40°C (100°F) liquid and 5°C (10°F) superheat entering the regulator. Capacities are maximum and have no reserve for excess loads. Capacities apply to any A4A or A4W regulator (or S4A and S4W) regardless of variation used.

Sub-cooled liquid: For each 5°C/10°F liquid is colder than base temperature, increase table values 4% for R404a.

Note: For liquid overfeed applications (nominal 2:1 to 5:1 ratio), add 20% to the evaporator load and select a regulator based on this increased load value.

Suction Capacities - A2

R-410a (KW)

Evap T (°C) P (barg)	Pressure Drop (bar)	A2B	A2BK	A2BP	A2A	A2BO1	A2BO2	A2BO4	A2CK
10° 9.87	0.14 0.34	1.25 1.96	1.00 1.57	1.25 1.96	3.75 5.89	0.25 0.39	0.50 0.79	1.25 1.96	5.75 9.04
5° 8.35	0.14 0.34	1.15 1.80	0.92 1.44	1.15 1.80	3.44 5.40	0.23 0.36	0.46 0.72	1.15 1.80	5.27 8.28
0° 6.99	0.14 0.34	1.05 1.64	0.84 1.32	1.05 1.64	3.14 4.93	0.21 0.33	0.42 0.66	1.05 1.64	4.82 7.56
-5° 5.79	0.14 0.34	0.96 1.50	0.76 1.20	0.96 1.50	2.87 4.49	0.19 0.30	0.38 0.60	0.96 1.50	4.39 6.88
-10° 4.73	0.14 0.34	0.87 1.36	0.69 1.08	0.87 1.36	2.60 4.07	0.17 0.27	0.35 0.54	0.87 1.36	3.99 6.24
-15° 3.80	0.14 0.34	0.78 1.22	0.63 0.98	0.78 1.22	2.35 3.67	0.16 0.24	0.31 0.49	0.78 1.22	3.61 5.63
-20° 2.99	0.14 0.34	0.71 1.10	0.56 0.88	0.71 1.10	2.12 3.30	0.14 0.22	0.28 0.44	0.71 1.10	3.25 5.05
-25° 2.29	0.14 0.34	0.63 0.98	0.51 0.79	0.63 0.98	1.90 2.94	0.13 0.20	0.25 0.39	0.63 0.98	2.91 4.51
-30° 1.69	0.14 0.34	0.56 0.87	0.45 0.70	0.56 0.87	1.69 2.61	0.11 0.17	0.23 0.35	0.56 0.87	2.60 4.01
-35° 1.18	0.14 0.34	0.50 0.77	0.40 0.61	0.50 0.77	1.50 2.30	0.10 0.15	0.20 0.31	0.50 0.77	2.30 3.53
-40° 0.74	0.14 0.34	0.44 0.67	0.35 0.54	0.44 0.67	1.32 2.01	0.09 0.13	0.18 0.27	0.44 0.67	2.03 3.08

R-410a (TONS)

Evap T (°F) P (psig)	Pressure Drop (psi)	A2B	A2BK	A2BP	A2A	A2BO1	A2BO2	A2BO4	A2CK
50° 143.2	2 5	0.43 0.67	0.34 0.54	0.43 0.67	1.28 2.01	0.09 0.13	0.17 0.27	0.43 0.67	1.96 3.08
40° 118.8	2 5	0.39 0.61	0.31 0.49	0.39 0.61	1.16 1.83	0.08 0.12	0.16 0.24	0.39 0.61	1.78 2.80
30° 97.4	2 5	0.35 0.55	0.28 0.44	0.35 0.55	1.05 1.65	0.07 0.11	0.14 0.22	0.35 0.55	1.61 2.53
20° 78.7	2 5	0.32 0.49	0.25 0.40	0.32 0.49	0.95 1.48	0.06 0.10	0.13 0.20	0.32 0.49	1.45 2.28
10° 62.4	2 5	0.28 0.44	0.23 0.35	0.28 0.44	0.85 1.33	0.06 0.09	0.11 0.18	0.28 0.44	1.30 2.04
0° 48.4	2 5	0.25 0.39	0.20 0.32	0.25 0.39	0.76 1.18	0.05 0.08	0.10 0.16	0.25 0.39	1.16 1.81
-10° 36.5	2 5	0.22 0.35	0.18 0.28	0.22 0.35	0.67 1.05	0.04 0.07	0.09 0.14	0.22 0.35	1.03 1.60
-20° 26.3	2 5	0.20 0.31	0.16 0.24	0.20 0.31	0.59 0.92	0.04 0.06	0.08 0.12	0.20 0.31	0.91 1.41
-30° 17.8	2 5	0.17 0.27	0.14 0.21	0.17 0.27	0.52 0.80	0.03 0.05	0.07 0.11	0.17 0.27	0.80 1.23
-40° 10.8	2 5	0.15 0.23	0.12 0.18	0.15 0.23	0.45 0.69	0.03 0.05	0.06 0.09	0.15 0.23	0.69 1.06

Capacities for R410a are based on 40°C (100°F) liquid and 5°C (10°F) superheat entering the regulator. Capacities are maximum and have no reserve for excess loads. Capacities apply to any A4A or A4W regulator (or S4A and S4W) regardless of variation used.

Sub-cooled liquid: For each 5°C/10°F liquid is colder than base temperature, increase table values 4% for R410a.

Note: For liquid overfeed applications (nominal 2:1 to 5:1 ratio), add 20% to the evaporator load and select a regulator based on this increased load value.

Suction Capacities - A2

R-507a (KW)

Evap T (°C) P (barg)	Pressure Drop (bar)	A2B	A2BK	A2BP	A2A	A2BO1	A2BO2	A2BO4	A2CK
10° 7.45	0.14 0.34	0.82 1.29	0.61 0.96	0.82 1.29	2.66 4.18	0.20 0.32	0.41 0.64	0.82 1.29	4.10 6.43
5° 6.28	0.14 0.34	0.74 1.16	0.56 0.87	0.74 1.16	2.41 3.78	0.19 0.29	0.37 0.58	0.74 1.16	3.71 5.82
0° 5.23	0.14 0.34	0.67 1.05	0.50 0.79	0.67 1.05	2.18 3.41	0.17 0.26	0.34 0.52	0.67 1.05	3.35 5.24
-5° 4.30	0.14 0.34	0.60 0.94	0.45 0.71	0.60 0.94	1.96 3.06	0.15 0.24	0.30 0.47	0.60 0.94	3.01 4.71
-10° 3.48	0.14 0.34	0.54 0.84	0.40 0.63	0.54 0.84	1.75 2.73	0.13 0.21	0.27 0.42	0.54 0.84	2.70 4.21
-15° 2.76	0.14 0.34	0.48 0.75	0.36 0.56	0.48 0.75	1.56 2.43	0.12 0.19	0.24 0.37	0.48 0.75	2.41 3.74
-20° 2.13	0.14 0.34	0.43 0.66	0.32 0.50	0.43 0.66	1.39 2.15	0.11 0.17	0.21 0.33	0.43 0.66	2.14 3.31
-25° 1.59	0.14 0.34	0.38 0.58	0.28 0.44	0.38 0.58	1.22 1.89	0.09 0.15	0.19 0.29	0.38 0.58	1.88 2.91
-30° 1.12	0.14 0.34	0.33 0.51	0.25 0.38	0.33 0.51	1.07 1.65	0.08 0.13	0.17 0.25	0.33 0.51	1.65 2.53
-35° 0.71	0.14 0.34	0.29 0.44	0.22 0.33	0.29 0.44	0.94 1.42	0.07 0.11	0.14 0.22	0.29 0.44	1.44 2.19
-40° 0.37	0.14 0.34	0.25 0.37	0.19 0.28	0.25 0.37	0.81 1.22	0.06 0.09	0.12 0.19	0.25 0.37	1.25 1.87

R-507a (TONS)

Evap T (°F) P (psig)	Pressure Drop (psi)	A2B	A2BK	A2BP	A2A	A2BO1	A2BO2	A2BO4	A2CK
50° 108.0	2 5	0.30 0.47	0.24 0.38	0.30 0.47	0.91 1.42	0.06 0.09	0.12 0.19	0.30 0.47	1.39 2.18
40° 89.2	2 5	0.27 0.42	0.22 0.34	0.27 0.42	0.81 1.27	0.05 0.08	0.11 0.17	0.27 0.42	1.25 1.95
30° 72.7	2 5	0.24 0.38	0.19 0.30	0.24 0.38	0.73 1.13	0.05 0.08	0.10 0.15	0.24 0.38	1.11 1.74
20° 58.3	2 5	0.21 0.34	0.17 0.27	0.21 0.34	0.64 1.01	0.04 0.07	0.09 0.13	0.21 0.34	0.99 1.54
10° 45.7	2 5	0.19 0.30	0.15 0.24	0.19 0.30	0.57 0.89	0.04 0.06	0.08 0.12	0.19 0.30	0.87 1.36
0° 34.8	2 5	0.17 0.26	0.13 0.21	0.17 0.26	0.50 0.78	0.03 0.05	0.07 0.10	0.17 0.26	0.77 1.19
-10° 25.5	2 5	0.15 0.23	0.12 0.18	0.15 0.23	0.44 0.68	0.03 0.05	0.06 0.09	0.15 0.23	0.67 1.04
-20° 17.6	2 5	0.13 0.19	0.10 0.16	0.13 0.19	0.38 0.58	0.03 0.04	0.05 0.08	0.13 0.19	0.58 0.89
-30° 11.0	2 5	0.11 0.17	0.09 0.13	0.11 0.17	0.33 0.50	0.02 0.03	0.04 0.07	0.11 0.17	0.50 0.76
-40° 5.4	2 5	0.09 0.14	0.07 0.11	0.09 0.14	0.28 0.42	0.02 0.03	0.04 0.06	0.09 0.14	0.43 0.64

Capacities for R507a are based on 40°C (100°F) liquid and 5°C (10°F) superheat entering the regulator. Capacities are maximum and have no reserve for excess loads. Capacities apply to any A4A or A4W regulator (or S4A and S4W) regardless of variation used.

Sub-cooled liquid: For each 5°C/10°F liquid is colder than base temperature, increase table values 4% for R507a.

Note: For liquid overfeed applications (nominal 2:1 to 5:1 ratio), add 20% to the evaporator load and select a regulator based on this increased load value.

Liquid Capacities - A2

R-717 (KG/MIN & M³/HR)

Liquid Temp (°C)	Press. Drop (bar)	A2B		A2BK		A2BP		A2A		A2BO1		A2BO2		A2BO4		A2CK	
		kg/min	m ³ /hr	kg/min	m ³ /hr	kg/min	m ³ /hr	kg/min	m ³ /hr	kg/min	m ³ /hr	kg/min	m ³ /hr	kg/min	m ³ /hr	kg/min	m ³ /hr
5°	0.69	4.4	0.4	3.3	0.3	4.4	0.4	14	1.4	1.1	0.1	2.2	0.2	4.4	0.4	22	2.1
-20°		4.5	0.4	3.4	0.3	4.5	0.4	15	1.3	1.1	0.1	2.3	0.2	4.5	0.4	23	2.0
-40°		4.6	0.4	3.4	0.3	4.6	0.4	15	1.3	1.1	0.1	2.3	0.2	4.6	0.4	23	2.0
5°	1.03	5.4	0.5	4.0	0.4	5.4	0.5	18	1.7	1.3	0.1	2.7	0.3	5.4	0.5	27	2.6
-20°		5.5	0.5	4.1	0.4	5.5	0.5	18	1.6	1.4	0.1	2.8	0.2	5.5	0.5	28	2.5
-40°		5.6	0.5	4.2	0.4	5.6	0.5	18	1.6	1.4	0.1	2.8	0.2	5.6	0.5	28	2.4
5°	1.38	6.2	0.6	4.7	0.4	6.2	0.6	20	1.9	1.6	0.1	3.1	0.3	6.2	0.6	31	3.0
-20°		6.4	0.6	4.8	0.4	6.4	0.6	21	1.9	1.6	0.1	3.2	0.3	6.4	0.6	32	2.9
-40°		6.5	0.6	4.9	0.4	6.5	0.6	21	1.8	1.6	0.1	3.3	0.3	6.5	0.6	33	2.8

R-717 (LB/MIN & GPM)

Liquid Temp (°F)	Press. Drop (psi)	A2B		A2BK		A2BP		A2A		A2BO1		A2BO2		A2BO4		A2CK	
		lb/min	gpm	lb/min	gpm	lb/min	gpm	lb/min	gpm	lb/min	gpm	lb/min	gpm	lb/min	gpm	lb/min	gpm
40°	10	10	2.0	8.4	1.6	10	2.0	31	6.0	2.1	0.4	4.2	0.8	10	2.0	48	9.1
0°		11	1.9	8.6	1.6	11	1.9	32	5.8	2.1	0.4	4.3	0.8	11	1.9	49	8.9
-40°		11	1.9	8.8	1.5	11	1.9	33	5.7	2.2	0.4	4.4	0.8	11	1.9	50	8.8
40°	15	13	2.4	10	1.9	13	2.4	39	7.3	2.6	0.5	5.1	1.0	13	2.4	59	11
0°		13	2.4	11	1.9	13	2.4	39	7.1	2.6	0.5	5.3	1.0	13	2.4	60	11
-40°		13	2.3	11	1.9	13	2.3	40	7.0	2.7	0.5	5.4	0.9	13	2.3	62	11
40°	20	15	2.8	12	2.2	15	2.8	44	8.4	3.0	0.6	5.9	1.1	15	2.8	68	13
0°		15	2.7	12	2.2	15	2.7	46	8.2	3.0	0.5	6.1	1.1	15	2.7	70	13
-40°		15	2.7	12	2.2	15	2.7	46	8.1	3.1	0.5	6.2	1.1	15	2.7	71	12

R-22 (KG/MIN & M³/HR)

Liquid Temp (°C)	Press. Drop (bar)	A2B		A2BK		A2BP		A2A		A2BO1		A2BO2		A2BO4		A2CK	
		kg/min	m ³ /hr	kg/min	m ³ /hr	kg/min	m ³ /hr	kg/min	m ³ /hr	kg/min	m ³ /hr	kg/min	m ³ /hr	kg/min	m ³ /hr	kg/min	m ³ /hr
5°	0.69	6.2	0.3	4.7	0.2	6.2	0.3	20	1.0	1.6	0.1	3.1	0.1	6.2	0.3	31	1.5
-20°		6.4	0.3	4.8	0.2	6.4	0.3	21	0.9	1.6	0.1	3.2	0.1	6.4	0.3	32	1.4
-40°		6.6	0.3	4.9	0.2	6.6	0.3	21	0.9	1.6	0.1	3.3	0.1	6.6	0.3	33	1.4
5°	1.03	7.6	0.4	5.7	0.3	7.6	0.4	25	1.2	1.9	0.1	3.8	0.2	7.6	0.4	38	1.8
-20°		7.9	0.4	5.9	0.3	7.9	0.4	26	1.1	2.0	0.1	3.9	0.2	7.9	0.4	39	1.8
-40°		8.0	0.3	6.0	0.3	8.0	0.3	26	1.1	2.0	0.1	4.0	0.2	8.0	0.3	40	1.7
5°	1.38	8.8	0.4	6.6	0.3	8.8	0.4	29	1.4	2.2	0.1	4.4	0.2	8.8	0.4	44	2.1
-20°		9.1	0.4	6.8	0.3	9.1	0.4	30	1.3	2.3	0.1	4.5	0.2	9.1	0.4	45	2.0
-40°		9.3	0.4	7.0	0.3	9.3	0.4	30	1.3	2.3	0.1	4.6	0.2	9.3	0.4	46	2.0

R-22 (LB/MIN & GPM)

Liquid Temp (°F)	Press. Drop (psi)	A2B		A2BK		A2BP		A2A		A2BO1		A2BO2		A2BO4		A2CK	
		lb/min	gpm	lb/min	gpm	lb/min	gpm	lb/min	gpm	lb/min	gpm	lb/min	gpm	lb/min	gpm	lb/min	gpm
40°	10	15	1.4	12	1.1	15	1.4	45	4.2	3.0	0.3	5.9	0.6	15	1.4	68	6.5
0°		15	1.4	12	1.1	15	1.4	46	4.1	3.1	0.3	6.1	0.5	15	1.4	70	6.3
-40°		16	1.3	13	1.1	16	1.3	47	4.0	3.1	0.3	6.3	0.5	16	1.3	72	6.1
40°	15	18	1.7	15	1.4	18	1.7	55	5.2	3.6	0.3	7.3	0.7	18	1.7	84	7.9
0°		19	1.7	15	1.3	19	1.7	56	5.0	3.7	0.3	7.5	0.7	19	1.7	86	7.7
-40°		19	1.6	15	1.3	19	1.6	57	4.9	3.8	0.3	7.7	0.7	19	1.6	88	7.5
40°	20	21	2.0	17	1.6	21	2.0	63	6.0	4.2	0.4	8.4	0.8	21	2.0	97	9.1
0°		22	1.9	17	1.5	22	1.9	65	5.8	4.3	0.4	8.6	0.8	22	1.9	99	8.9
-40°		22	1.9	18	1.5	22	1.9	66	5.7	4.4	0.4	8.8	0.8	22	1.9	102	8.7

Capacities are based on -18°C (0°F) liquid ammonia and no flash gas.

For evaporator temperatures between 4°C to -40°C (40°F to -40°F), capacities are within 5%.

Correction factors for temperatures between -40°C (-40°F) and 30°C (86°F) are negligible.

Liquid Capacities - A2

R-134a (KG/MIN & M³/HR)

Liquid Temp (°C)	Press. Drop (bar)	A2B		A2BK		A2BP		A2A		A2BO1		A2BO2		A2BO4		A2CK	
		kg/min	m ³ /hr	kg/min	m ³ /hr	kg/min	m ³ /hr	kg/min	m ³ /hr	kg/min	m ³ /hr	kg/min	m ³ /hr	kg/min	m ³ /hr	kg/min	m ³ /hr
5°	0.69	6.3	0.3	4.7	0.2	6.3	0.3	20	1.0	1.6	0.1	3.1	0.1	6.3	0.3	31	1.5
-20°		6.4	0.3	4.8	0.2	6.4	0.3	21	0.9	1.6	0.1	3.2	0.1	6.4	0.3	32	1.4
-40°		6.6	0.3	4.9	0.2	6.6	0.3	21	0.9	1.6	0.1	3.3	0.1	6.6	0.3	33	1.4
5°	1.03	7.7	0.4	5.7	0.3	7.7	0.4	25	1.2	1.9	0.1	3.8	0.2	7.7	0.4	38	1.8
-20°		7.9	0.3	5.9	0.3	7.9	0.3	26	1.1	2.0	0.1	3.9	0.2	7.9	0.3	39	1.7
-40°		8.1	0.3	6.1	0.3	8.1	0.3	26	1.1	2.0	0.1	4.0	0.2	8.1	0.3	40	1.7
5°	1.38	8.8	0.4	6.6	0.3	8.8	0.4	29	1.3	2.2	0.1	4.4	0.2	8.8	0.4	44	2.1
-20°		9.1	0.4	6.8	0.3	9.1	0.4	30	1.3	2.3	0.1	4.6	0.2	9.1	0.4	46	2.0
-40°		9.3	0.4	7.0	0.3	9.3	0.4	30	1.3	2.3	0.1	4.7	0.2	9.3	0.4	47	2.0

R-134a (LB/MIN & GPM)

Liquid Temp (°F)	Press. Drop (psi)	A2B		A2BK		A2BP		A2A		A2BO1		A2BO2		A2BO4		A2CK	
		lb/min	gpm	lb/min	gpm	lb/min	gpm	lb/min	gpm	lb/min	gpm	lb/min	gpm	lb/min	gpm	lb/min	gpm
40°	10	15	1.4	12	1.1	15	1.4	45	4.2	3.0	0.3	6.0	0.6	15	1.4	69	6.4
0°		15	1.4	12	1.1	15	1.4	46	4.1	3.1	0.3	6.1	0.5	15	1.4	71	6.3
-40°		16	1.3	13	1.1	16	1.3	47	4.0	3.1	0.3	6.3	0.5	16	1.3	72	6.1
40°	15	18	1.7	15	1.4	18	1.7	55	5.1	3.7	0.3	7.3	0.7	18	1.7	84	7.9
0°		19	1.7	15	1.3	19	1.7	56	5.0	3.8	0.3	7.5	0.7	19	1.7	86	7.7
-40°		19	1.6	15	1.3	19	1.6	58	4.9	3.8	0.3	7.7	0.7	19	1.6	88	7.5
40°	20	21	2.0	17	1.6	21	2.0	63	5.9	4.2	0.4	8.4	0.8	21	2.0	97	9.1
0°		22	1.9	17	1.5	22	1.9	65	5.8	4.3	0.4	8.7	0.8	22	1.9	100	8.8
-40°		22	1.9	18	1.5	22	1.9	67	5.6	4.4	0.4	8.9	0.8	22	1.9	102	8.6

R-404a (KG/MIN & M³/HR)

Liquid Temp (°C)	Press. Drop (bar)	A2B		A2BK		A2BP		A2A		A2BO1		A2BO2		A2BO4		A2CK	
		kg/min	m ³ /hr	kg/min	m ³ /hr	kg/min	m ³ /hr	kg/min	m ³ /hr	kg/min	m ³ /hr	kg/min	m ³ /hr	kg/min	m ³ /hr	kg/min	m ³ /hr
5°	0.69	5.9	0.3	4.4	0.2	5.9	0.3	19	1.0	1.5	0.1	2.9	0.2	5.9	0.3	29	1.6
-20°		6.1	0.3	4.6	0.2	6.1	0.3	20	1.0	1.5	0.1	3.1	0.2	6.1	0.3	31	1.5
-40°		6.3	0.3	4.7	0.2	6.3	0.3	20	1.0	1.6	0.1	3.1	0.1	6.3	0.3	31	1.5
5°	1.03	7.2	0.4	5.4	0.3	7.2	0.4	23	1.2	1.8	0.1	3.6	0.2	7.2	0.4	36	1.9
-20°		7.5	0.4	5.6	0.3	7.5	0.4	24	1.2	1.9	0.1	3.7	0.2	7.5	0.4	37	1.8
-40°		7.7	0.4	5.8	0.3	7.7	0.4	25	1.2	1.9	0.1	3.8	0.2	7.7	0.4	38	1.8
5°	1.38	8.3	0.4	6.2	0.3	8.3	0.4	27	1.4	2.1	0.1	4.2	0.2	8.3	0.4	42	2.2
-20°		8.6	0.4	6.5	0.3	8.6	0.4	28	1.4	2.2	0.1	4.3	0.2	8.6	0.4	43	2.1
-40°		8.9	0.4	6.7	0.3	8.9	0.4	29	1.3	2.2	0.1	4.4	0.2	8.9	0.4	44	2.1

R-404a (LB/MIN & GPM)

Liquid Temp (°F)	Press. Drop (psi)	A2B		A2BK		A2BP		A2A		A2BO1		A2BO2		A2BO4		A2CK	
		lb/min	gpm	lb/min	gpm	lb/min	gpm	lb/min	gpm	lb/min	gpm	lb/min	gpm	lb/min	gpm	lb/min	gpm
40°	10	14	1.5	11	1.2	14	1.5	42	4.5	2.8	0.3	5.6	0.6	14	1.5	65	6.8
0°		15	1.4	12	1.1	15	1.4	44	4.3	2.9	0.3	5.8	0.6	15	1.4	67	6.6
-40°		15	1.4	12	1.1	15	1.4	45	4.2	3.0	0.3	6.0	0.6	15	1.4	69	6.4
40°	15	17	1.8	14	1.5	17	1.8	52	5.5	3.4	0.4	6.9	0.7	17	1.8	79	8.4
0°		18	1.8	14	1.4	18	1.8	53	5.3	3.6	0.4	7.1	0.7	18	1.8	82	8.1
-40°		18	1.7	15	1.4	18	1.7	55	5.1	3.7	0.3	7.3	0.7	18	1.7	84	7.8
40°	20	20	2.1	16	1.7	20	2.1	60	6.3	4.0	0.4	7.9	0.8	20	2.1	91	10
0°		21	2.0	16	1.6	21	2.0	62	6.1	4.1	0.4	8.2	0.8	21	2.0	95	9.3
-40°		21	2.0	17	1.6	21	2.0	63	5.9	4.2	0.4	8.5	0.8	21	2.0	97	9.1

Capacities are based on -18°C (0°F) liquid ammonia and no flash gas.

For evaporator temperatures between 4°C to -40°C (40°F to -40°F), capacities are within 5%.

Correction factors for temperatures between -40°C (-40°F) and 30°C (86°F) are negligible.

Liquid Capacities - A2

R-410a (KG/MIN & M³/HR)

Liquid Temp (°C)	Press. Drop (bar)	A2B		A2BK		A2BP		A2A		A2BO1		A2BO2		A2BO4		A2CK	
		kg/min	m ³ /hr	kg/min	m ³ /hr	kg/min	m ³ /hr	kg/min	m ³ /hr	kg/min	m ³ /hr	kg/min	m ³ /hr	kg/min	m ³ /hr	kg/min	m ³ /hr
5°	0.69	5.9	0.3	4.4	0.2	5.9	0.3	19	1.0	1.5	0.1	3.0	0.2	5.9	0.3	30	1.5
-20°		6.2	0.3	4.6	0.2	6.2	0.3	20	1.0	1.5	0.1	3.1	0.1	6.2	0.3	31	1.5
-40°		6.3	0.3	4.8	0.2	6.3	0.3	21	0.9	1.6	0.1	3.2	0.1	6.3	0.3	32	1.4
5°	1.03	7.3	0.4	5.4	0.3	7.3	0.4	24	1.2	1.8	0.1	3.6	0.2	7.3	0.4	36	1.9
-20°		7.6	0.4	5.7	0.3	7.6	0.4	25	1.2	1.9	0.1	3.8	0.2	7.6	0.4	38	1.8
-40°		7.8	0.4	5.8	0.3	7.8	0.4	25	1.2	1.9	0.1	3.9	0.2	7.8	0.4	39	1.8
5°	1.38	8.4	0.4	6.3	0.3	8.4	0.4	27	1.4	2.1	0.1	4.2	0.2	8.4	0.4	42	2.2
-20°		8.7	0.4	6.5	0.3	8.7	0.4	28	1.4	2.2	0.1	4.4	0.2	8.7	0.4	44	2.1
-40°		9.0	0.4	6.7	0.3	9.0	0.4	29	1.3	2.2	0.1	4.5	0.2	9.0	0.4	45	2.0

R-410a (LB/MIN & GPM)

Liquid Temp (°F)	Press. Drop (psi)	A2B		A2BK		A2BP		A2A		A2BO1		A2BO2		A2BO4		A2CK	
		lb/min	gpm	lb/min	gpm	lb/min	gpm	lb/min	gpm	lb/min	gpm	lb/min	gpm	lb/min	gpm	lb/min	gpm
40°	10	14	1.5	11	1.2	14	1.5	42	4.4	2.8	0.3	5.7	0.6	14	1.5	65	6.8
0°		15	1.4	12	1.1	15	1.4	44	4.3	2.9	0.3	5.9	0.6	15	1.4	67	6.5
-40°		15	1.4	12	1.1	15	1.4	45	4.1	3.0	0.3	6.0	0.6	15	1.4	70	6.3
40°	15	17	1.8	14	1.4	17	1.8	52	5.4	3.5	0.4	6.9	0.7	17	1.8	80	8.3
0°		18	1.7	14	1.4	18	1.7	54	5.2	3.6	0.3	7.2	0.7	18	1.7	83	8.0
-40°		19	1.7	15	1.4	19	1.7	56	5.1	3.7	0.3	7.4	0.7	19	1.7	85	7.8
40°	20	20	2.1	16	1.7	20	2.1	60	6.2	4.0	0.4	8.0	0.8	20	2.1	92	10
0°		21	2.0	17	1.6	21	2.0	62	6.0	4.1	0.4	8.3	0.8	21	2.0	95	9.2
-40°		21	2.0	17	1.6	21	2.0	64	5.9	4.3	0.4	8.5	0.8	21	2.0	98	9.0

R-507a (KG/MIN & M³/HR)

Liquid Temp (°C)	Press. Drop (bar)	A2B		A2BK		A2BP		A2A		A2BO1		A2BO2		A2BO4		A2CK	
		kg/min	m ³ /hr	kg/min	m ³ /hr	kg/min	m ³ /hr	kg/min	m ³ /hr	kg/min	m ³ /hr	kg/min	m ³ /hr	kg/min	m ³ /hr	kg/min	m ³ /hr
5°	0.69	5.9	0.3	4.4	0.2	5.9	0.3	19	1.0	1.5	0.1	2.9	0.2	5.9	0.3	29	1.6
-20°		6.1	0.3	4.6	0.2	6.1	0.3	20	1.0	1.5	0.1	3.1	0.1	6.1	0.3	31	1.5
-40°		6.3	0.3	4.7	0.2	6.3	0.3	20	0.9	1.6	0.1	3.1	0.1	6.3	0.3	31	1.5
5°	1.03	7.2	0.4	5.4	0.3	7.2	0.4	23	1.2	1.8	0.1	3.6	0.2	7.2	0.4	36	1.9
-20°		7.5	0.4	5.6	0.3	7.5	0.4	24	1.2	1.9	0.1	3.8	0.2	7.5	0.4	38	1.8
-40°		7.7	0.4	5.8	0.3	7.7	0.4	25	1.2	1.9	0.1	3.9	0.2	7.7	0.4	39	1.8
5°	1.38	8.3	0.4	6.3	0.3	8.3	0.4	27	1.4	2.1	0.1	4.2	0.2	8.3	0.4	42	2.2
-20°		8.7	0.4	6.5	0.3	8.7	0.4	28	1.4	2.2	0.1	4.3	0.2	8.7	0.4	43	2.1
-40°		8.9	0.4	6.7	0.3	8.9	0.4	29	1.3	2.2	0.1	4.5	0.2	8.9	0.4	45	2.1

R-507a (LB/MIN & GPM)

Liquid Temp (°F)	Press. Drop (psi)	A2B		A2BK		A2BP		A2A		A2BO1		A2BO2		A2BO4		A2CK	
		lb/min	gpm	lb/min	gpm	lb/min	gpm	lb/min	gpm	lb/min	gpm	lb/min	gpm	lb/min	gpm	lb/min	gpm
40°	10	14	1.5	11	1.2	14	1.5	42	4.4	2.8	0.3	5.6	0.6	14	1.5	65	6.8
0°		15	1.4	12	1.1	15	1.4	44	4.3	2.9	0.3	5.8	0.6	15	1.4	67	6.6
-40°		15	1.4	12	1.1	15	1.4	45	4.2	3.0	0.3	6.0	0.6	15	1.4	69	6.4
40°	15	17	1.8	14	1.5	17	1.8	52	5.4	3.4	0.4	6.9	0.7	17	1.8	79	8.3
0°		18	1.8	14	1.4	18	1.8	54	5.3	3.6	0.4	7.1	0.7	18	1.8	82	8.1
-40°		18	1.7	15	1.4	18	1.7	55	5.1	3.7	0.3	7.4	0.7	18	1.7	85	7.8
40°	20	20	2.1	16	1.7	20	2.1	60	6.3	4.0	0.4	8.0	0.8	20	2.1	92	10
0°		21	2.0	16	1.6	21	2.0	62	6.1	4.1	0.4	8.2	0.8	21	2.0	95	9.3
-40°		21	2.0	17	1.6	21	2.0	64	5.9	4.2	0.4	8.5	0.8	21	2.0	98	9.0

Capacities are based on -18°C (0°F) liquid ammonia and no flash gas.

For evaporator temperatures between 4°C to -40°C (40°F to -40°F), capacities are within 5%.

Correction factors for temperatures between -40°C (-40°F) and 30°C (86°F) are negligible.

Solenoid Valves

The solenoid valves include direct operated and pilot operated valves. Selections for most refrigeration applications are available – liquid, suction, hot gas and compressor unloading. Low or no pressure differential, equalizing and vent solenoid in sizes up to 50mm (2”).

Explosion proof SV2X and S4X hazardous environment type solenoids carry NEMA Type 4 and 7 classification.

Specifications

Maximum Opening Pressure Difference (MOPD) .. 20.7 barg (300 psig)
 Maximum Rated Pressure (MRP) 27.6 barg (400 psig)
 SV2 only 31.0 barg (450 psig)

DIN Specifications

Maximum Opening Pressure Difference (MOPD) ... 20.7 barg (300 psig)
 Maximum Rated Pressure (MRP) 28 barg (406 psig)

*For more specifications see page [34](#)



General Information

Port Size		Type	Description	Flow Coefficient		Connections Available		
mm	inch			Kv	Cv	FPT, SW, WN	ODS	WN (DN)
5	3/16	S6N	NC, Direct Operated	0.5	0.6	1/4", 3/8", 1/2", 3/4"	1/2", 5/8"	13, 20
13	1/2	S8F	NC, Spring Assisted	2.3	2.7	1/4", 3/8", 1/2", 3/4"	1/2", 5/8"	13, 20
		SV2		2.6	3.0			
20	3/4	SV2	NC, Spring Assisted	6.0	7.0	3/4", 1", 1 1/4"	7/8", 1 1/8", 1 3/8"	20, 25, 32
		S4A		6.9	8.1			
		S7A		8.7	10			
25	1	S4A	NC, Spring Assisted	8.4	9.9	3/4", 1", 1 1/4"	7/8", 1 1/8", 1 3/8"	20, 25, 32
		S7A	NC, Direct Operated	9.2	11			
		SV2	NC, Spring Assisted	10	12			
32	1 1/4	S4A	NC, Spring Assisted	17	20	1 1/4", 1 1/2"	1 5/8"	32
		S5A	NC, Gravity Assisted	16	19			
		SV2	NC, Spring Assisted	16	19			
40	1 5/8	S4A	NC, Spring Assisted	27	32	1 1/2", 2"	2 1/8", 2 5/8"	38, 50
		S5A	NC, Gravity Assisted	32	37			
50	2	S4A	NC, Spring Assisted	46	53	1 1/2", 2"	2 1/8", 2 5/8"	38, 50
		S5A	NC, Gravity Assisted	44	51			
65	2 1/2	S4A	NC, Spring Assisted	64	75	2 1/2", 3" (No FPT)	2 5/8", 3 1/8"	65
		S5A	NC, Gravity Assisted	70	82			
75	3	S4A	NC, Spring Assisted	86	100	3" (No FPT)	3 1/8", 3 5/8"	75
		S5A	NC, Gravity Assisted	98	120			
100	4	S4A	NC, Spring Assisted	130	150	4" (No FPT)	4 1/8"	100
125	5	S4W	NC, Spring Assisted	170	200	WN only		
150	6	S4W	NC, Spring Assisted	310	360	WN only		
200	8	S4W	NC, Spring Assisted	470	550	WN only		

S4A and S4W are available with 1/4" FPT connection for EXTERNAL supply of actuating pressure. Specify S4AE or S4WE. S5A is available with 1/4" FPT connection for external connection to outlet pressure.

Solenoid Valves

Solenoids

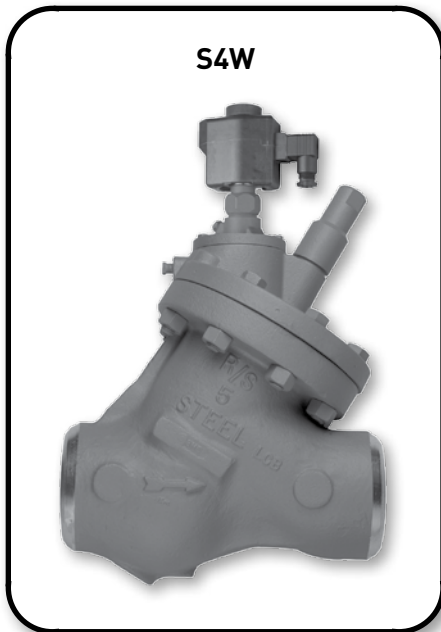
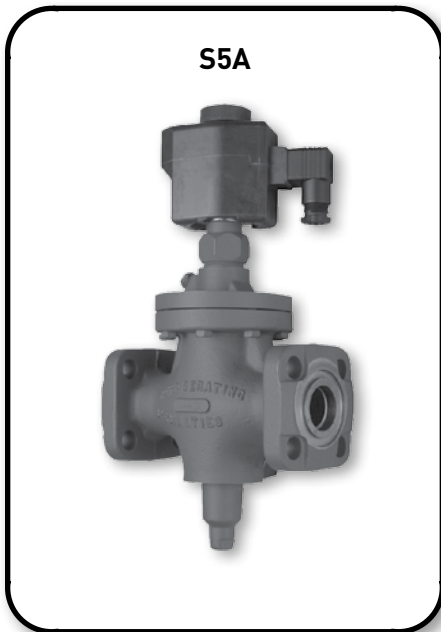

Specifications

Port Size		Type	Seat Material	Standard Body Material	*DIN Body Material	Minimum Pressure Drop		Temperature Range		Operation	Bulletin
mm	inch					bar	psi	°C	°F		
5	3/16	S6N	PTFE	Ductile Iron	GGG-40.3	0	0	-50 to 105	-60 to 220	Normally Closed	30-90
13	1/2	S8F	PTFE	Ductile Iron	Stainless Steel	0.07	1	-50 to 105	-60 to 220	Normally Closed	30-91
20 - 25	3/4 - 1	S7A	PTFE	Gray Iron	GGG-40.3	0	0	-30 to 105	-25 to 220	Normally Closed	30-92
13 - 32	1/2 - 1 1/4	SV2	PTFE	Ductile Iron	N/A	0.24	3.5	-45 to 105	-50 to 220	Normally Closed	30-06
32	1 1/4	S5A	PTFE	Gray Iron	GGG-40.3	0.07	1	-30 to 105	-25 to 220	Normally Closed	30-93
40 - 75	1 5/8 - 3	S5A	Metal	Gray Iron	GGG-40.3	0.07	1	-30 to 105	-25 to 220	Normally Closed	30-93
20 - 32	3/4 - 1 1/4	S4A	PTFE	Gray Iron	GGG-40.3	0.28	4	-45 to 105	-50 to 220	Normally Closed	30-94
40 - 100	1 5/8 - 4	S4A	Metal	Gray Iron	GGG-40.3	0.14	2	-50 to 105	-60 to 220	Normally Closed	30-94
125 - 200	5 - 8	S4W	Metal	Cast Steel	N/A	0.14	2	-50 to 105	-60 to 220	Normally Closed	30-05

*Complies with Pressure Equipment Directive 97/23/EC

Application Guide

Refrigerant Application	Refrigerant Temperature Range	Valve Recommendation - Listed by Port Size										
		5mm	13mm	20mm	25mm	32mm	40mm	50mm	65mm	75mm	100mm	125-200mm
		3/16"	1/2"	3/4"	1"	1 1/4"	1 5/8"	2"	2 1/2"	3"	4"	5"-8"
Liquid	Conventional Warm High Pressure	S6N	S8F SV2	S4A SV2	S4A SV2	S4A SV2	S4A	S4A	S4A	S4A	S4A	S4W
	Above -50°C (-60°F)	S6N	S8F	—	—	—	S4A	S4A	S4A	S4A	S4A	S4W
	Above -45°C (-50°F)	S6N	S8F SV2	S4A SV2	S4A SV2	S4A SV2	S4A	S4A	S4A	S4A	S4A	S4W
Suction	Above -30°C (-25°F)	S6N	S8F	S7A	S7A	S5A	S5A	S5A	S5A	S5A	S5A	S4W
Hot Gas Defrost	Below 105°C (220°F)	S6N	S8F SV2	S4A SV2	S4A SV2	S4A SV2	S4A	S4A	S4A	S4A	S4A	S4W
Bypass Compressor Unloading	Below 105°C (220°F)	S6N	S8F	S7A	S7A	S4AE	S4AE	S4AE	S4AE	S4AE	S4AE	—
Equalizing Lines	—	S6N	—	S7A	S7A	—	—	—	—	—	—	—

Solenoid Valves

R-717 (KW)

Port Size mm	Type	Liquid Capacities ①		Suction Capacities ②				Hot Gas Reclaim ③					
		0.14 bar ΔP	0.27 bar ΔP	0.07 bar ΔP		0.14 bar ΔP		21°C Condensing		30°C Condensing		35°C Condensing	
				-10°C	-20°C	-10°C	-20°C	0.24 bar ΔP	0.34 bar ΔP	0.24 bar ΔP	0.34 bar ΔP	0.24 bar ΔP	0.34 bar ΔP
5	S6N	55	77	—	—	—	—	—	—	—	—	—	—
13	S8F SV2	249	346	9.3	7.5	13	11	—	—	—	—	—	—
		—	385	—	—	—	—	35	41	38	46	40	48
20	S4A ④ S7A SV2	—	923	—	—	—	—	83	99	92	110	97	116
		739	1026	28	22	39	32	—	—	—	—	—	—
		—	897	—	—	—	—	81	96	90	107	94	112
25	S4A S7A SV2	—	1282	—	—	—	—	116	138	128	152	135	161
		923	1282	34	28	49	39	—	—	—	—	—	—
		—	1538	—	—	—	—	139	165	154	183	162	193
32	S4A S5A SV2	—	2243	—	—	—	—	202	241	224	267	236	281
		1754	2436	65	53	93	75	—	—	—	—	—	—
		—	2436	—	—	—	—	220	261	243	290	256	305
40	S4A S5A	3083	4282	—	—	163	132	386	460	428	509	451	537
		3416	4743	127	103	180	146	—	—	—	—	—	—
50	S4A S5A	4570	6346	—	—	241	195	572	681	634	755	668	795
		4708	6538	176	142	248	201	—	—	—	—	—	—
65	S4A S5A	6462	8974	—	—	341	276	809	963	897	1067	945	1125
		7570	10512	282	229	399	323	—	—	—	—	—	—
75	S4A S5A	9231	12820	—	—	487	394	1156	1376	1281	1525	1350	1607
		10616	14743	396	321	560	453	—	—	—	—	—	—
100	S4A	14955	20768	Use CK-2 or S9A ⑤		789	639	1873	2230	2075	2470	2187	2603
125	S4W	—	—	Use CK-2 or S9A ⑤		974	788	2313	2753	2562	3049	2700	3213
150	S4W	—	—	Use CK-2 or S9A ⑤		1753	1419	4163	4955	4611	5488	4860	5784
200	S4W	—	—	Use CK-2 or S9A ⑤		2679	2168	6360	7569	7045	8385	7424	8837

All capacities are maximum for the conditions listed and have no reserve for excess loads.

- ① R717 capacities are based on -7°C liquid with no flashing, -15°C evaporator temperature and no liquid overfeed. For liquid overfeed, multiply evaporator KW by recirculating rate and size valve to the KW result. Use of -7°C liquid for capacities in this table is sufficiently accurate for most liquid overfeed systems. To convert for 30°C input, multiply values in the table by 0.9.
- ② R717 capacities are based on 30°C condensing temperature and the evaporator temperatures listed. See A4A suction capacities on page **10** for other pressure drops and for corrections for liquid overfeed and sub-cooled liquid.
- ③ Hot gas heat reclaim capacities are in terms of heat of condensation rejected at the condenser and are based on saturated inlet conditions at pressures equivalent to the condensing temperatures and for the pressure drops listed.
- ④ The 20mm port size S4A is available with capacities equal to 50% of the ratings shown.
- ⑤ CK-2 and S9A. See page **49** and **52** for low pressure drop at temperatures below -10°C.

Solenoid Valves

R-717 (TONS)

Port Size	Type	Liquid Capacities ①		Suction Capacities ②				Hot Gas Reclaim ③					
		2 psi ΔP	4 psi ΔP	1 psi ΔP		2 psi ΔP		70°F Condensing		86°F Condensing		95°F Condensing	
				20°F	0°F	20°F	0°F	3.5 psi ΔP	5 psi ΔP	3.5 psi ΔP	5 psi ΔP	3.5 psi ΔP	5 psi ΔP
Inch													
3/16	S6N	16	22	—	—	—	—	—	—	—	—	—	—
1/2	S8F	70	99	2.8	2.2	4.0	3.2	—	—	—	—	—	—
	SV2	—	110	—	—	—	—	119	142	132	157	139	166
3/4	S4A ④	—	265	—	—	—	—	285	341	316	377	333	398
	S7A	208	295	8.3	6.6	12	9.3	—	—	—	—	—	—
	SV2	—	258	—	—	—	—	277	332	307	367	324	387
1	S4A	—	368	—	—	—	—	396	474	439	524	462	552
	S7A	260	368	10	8.3	15	12	—	—	—	—	—	—
	SV2	—	442	—	—	—	—	476	569	526	629	555	663
1 1/4	S4A	—	644	—	—	—	—	694	829	767	917	809	967
	S5A	495	699	20	16	28	22	—	—	—	—	—	—
	SV2	—	699	—	—	—	—	753	900	833	996	878	1050
1 5/8	S4A	869	1230	—	—	49	39	1324	1582	1465	1751	1544	1845
	S5A	963	1362	38	31	54	43	—	—	—	—	—	—
2	S4A	1289	1822	—	—	73	58	1962	2345	2171	2594	2288	2734
	S5A	1328	1878	53	42	75	60	—	—	—	—	—	—
2 1/2	S4A	1822	2577	—	—	103	82	2775	3317	3070	3669	3235	3867
	S5A	2135	3019	85	68	121	96	—	—	—	—	—	—
3	S4A	2603	3681	120	—	147	117	3964	4738	4385	5241	4622	5524
	S5A	2994	4234	—	95	169	134	—	—	—	—	—	—
4	S4A	4217	5964	Use CK-2 or S9A ⑤		238	189	6422	7675	7104	8491	7487	8949
5	S4W	—	—	Use CK-2 or S9A ⑤		294	234	7928	9476	8771	10483	9243	11048
6	S4W	—	—	Use CK-2 or S9A ⑤		529	421	14271	17057	15787	18869	16638	19886
8	S4W	—	—	Use CK-2 or S9A ⑤		809	643	21802	26059	24119	28828	25419	30382

All capacities are maximum for the conditions listed and have no reserve for excess loads.

① R717 capacities are based on 20°F liquid with no flashing, 5°F evaporator temperature and no liquid overfeed. For liquid overfeed, multiply evaporator ton by recirculating rate and size valve to the ton result. Use of 20°F liquid for capacities in this table is sufficiently accurate for most liquid overfeed systems. To convert for 86°F input, multiply values in the table by 0.9.

② R717 capacities are based on 86°F condensing temperature and the evaporator temperatures listed. See A4A suction capacities on page **11** for other pressure drops and for corrections for liquid overfeed and sub-cooled liquid.

③ Hot gas heat reclaim capacities are in terms of heat of condensation rejected at the condenser and are based on saturated inlet conditions at pressures equivalent to the condensing temperatures and for the pressure drops listed.

④ The 3/4" port size S4A is available with capacities equal to 50% of the ratings shown.

⑤ CK-2 and S9A. See page **49** and **52** for low pressure drop at temperatures below 14°F.

Solenoid Valves

R-22 (KW)

Port Size	Type	Liquid Capacities ①		Suction Capacities ②				Hot Gas Reclaim ③					
		0.14 bar ΔP	0.27 bar ΔP	0.07 bar ΔP		0.14 bar ΔP		32°C Condensing		43°C Condensing		54°C Condensing	
				-10°C	-20°C	-10°C	-20°C	0.24 bar ΔP	0.34 bar ΔP	0.24 bar ΔP	0.34 bar ΔP	0.24 bar ΔP	0.34 bar ΔP
mm													
5	S6N	9.0	12	0.7	0.6	1.0	0.8	—	—	—	—	—	—
13	S8F SV2	41 —	56 62	3.2 —	2.7 —	4.6 —	3.8 —	— 14	— 17	— 15	— 18	— 16	— 19
20	S4A ④ S7A SV2	— 120 —	150 167 146	— 10 —	— 7.9 —	— 14 —	— 11 —	34 — 33	41 — 40	37 — 36	44 — 43	39 — 38	46 — 45
25	S4A S7A SV2	— 150 —	208 208 250	— 12 —	— 10 —	— 17 —	— 14 —	48 — 57	57 — 68	51 — 62	61 — 73	54 — 65	64 — 77
32	S4A S5A SV2	— 285 —	365 396 396	— 23 —	— 19 —	— 32 —	— 26 —	84 — 91	99 — 108	90 — 98	107 — 116	95 — 103	113 — 122
40	S4A S5A	501 555	696 771	— 45	— 36	57 63	46 51	160 —	190 —	171 —	204 —	180 —	215 —
50	S4A S5A	743 765	1031 1062	— 61	— 50	84 87	69 71	236 —	281 —	254 —	302 —	267 —	318 —
65	S4A S5A	1050 1230	1458 1708	— 99	— 81	119 140	97 114	334 —	398 —	359 —	428 —	378 —	450 —
75	S4A S5A	1500 1725	2083 2396	— 140	— 113	170 196	139 160	478 —	568 —	513 —	611 —	540 —	643 —
100	S4A	2430	3375	—	—	276	225	774	921	831	990	875	1042
125	S4W	—	—	—	—	—	—	955	1137	1026	1222	1081	1286
150	S4W	—	—	—	—	—	—	1719	2047	1848	2199	1945	2315
200	S4W	—	—	—	—	—	—	2627	3127	2823	3360	2972	3537

All capacities are maximum for the conditions listed and have no reserve for excess loads.

- ① Liquid capacities for R22 are based on 40°C condensing and 5°C evaporator temperatures with no flashing through the valve for the pressure drops listed. For each 5°C liquid is below 40°C, INCREASE values by 5%.
- ② Suction capacities for R22 are based on 40°C liquid and 5°C superheat entering the valve at the pressure drops and evaporator temperatures listed. For each 5°C liquid is below 40°C, INCREASE values by 5%.
- ③ Hot gas heat reclaim capacities are in terms of heat of condensation rejected at the condenser and are based on saturated inlet conditions at pressures equivalent to the condensing temperatures and for the pressure drops listed.
- ④ The 20mm port size S4A is available with capacities equal to 50% of the ratings shown.

Solenoid Valves

R-22 (TONS)

Port Size	Type	Liquid Capacities ①		Suction Capacities ②				Hot Gas Reclaim ③					
		2 psi ΔP	4 psi ΔP	1 psi ΔP		2 psi ΔP		90°F Condensing		110°F Condensing		130°F Condensing	
				20°F	0°F	20°F	0°F	3.5 psi ΔP	5 psi ΔP	3.5 psi ΔP	5 psi ΔP	3.5 psi ΔP	5 psi ΔP
Inch													
3/16	S6N	2.6	3.7	0.2	0.2	0.3	0.3	—	—	—	—	—	—
1/2	S8F	12	17	1.0	0.8	1.4	1.1	—	—	—	—	—	—
	SV2	—	18	—	—	—	—	49	59	53	63	56	66
3/4	S4A ④	—	44	—	—	—	—	118	141	127	151	133	159
	S7A	35	49	3.0	2.4	4.2	3.4	—	—	—	—	—	—
	SV2	—	43	—	—	—	—	115	137	123	147	130	155
1	S4A	—	61	—	—	—	—	164	196	176	210	185	221
	S7A	43	61	3.7	3.0	5.2	4.2	—	—	—	—	—	—
	SV2	—	73	—	—	—	—	197	235	211	252	222	266
1 1/4	S4A	—	107	—	—	—	—	287	343	308	368	324	388
	S5A	82	116	7.0	5.6	9.9	8.0	—	—	—	—	—	—
	SV2	—	116	—	—	—	—	311	372	334	400	352	421
1 5/8	S4A	145	204	—	—	17	14	547	654	588	703	619	740
	S5A	160	227	14	11	19	16	—	—	—	—	—	—
2	S4A	210	303	—	—	26	21	811	969	871	1042	917	1096
	S5A	221	312	19	15	27	21	—	—	—	—	—	—
2 1/2	S4A	303	429	—	—	37	29	1147	1370	1232	1473	1297	1550
	S5A	350	502	30	24	43	34	—	—	—	—	—	—
3	S4A	433	612	—	—	52	42	1638	1958	1760	2104	1853	2215
	S5A	498	704	43	34	60	48	—	—	—	—	—	—
4	S4A	701	992	—	—	85	68	2653	3171	2852	3409	3002	3588
5	S4W	—	—	—	—	—	—	3276	3915	3521	4208	3706	4429
6	S4W	—	—	—	—	—	—	5896	7048	6337	7575	6671	7973
8	S4W	—	—	—	—	—	—	9009	10767	9682	11572	10191	12181

All capacities are maximum for the conditions listed and have no reserve for excess loads.

① Liquid capacities for R22 are based on 100°F condensing and 40°F evaporator temperatures with no flashing through the valve for the pressure drops listed. For each 40°F liquid is below 100°F, INCREASE values by 5%.

② Suction capacities for R22 are based on 100°F liquid and 40°F superheat entering the valve at the pressure drops and evaporator temperatures listed. For each 10°F liquid is below 100°F, INCREASE values by 5%.

③ Hot gas heat reclaim capacities are in terms of heat of condensation rejected at the condenser and are based on saturated inlet conditions at pressures equivalent to the condensing temperatures and for the pressure drops listed.

④ The 3/4" port size S4A is available with capacities equal to 50% of the ratings shown.

Solenoid Valves

R-134a (KW)

Port Size	Type	Liquid Capacities ①		Suction Capacities ②				Hot Gas Reclaim ③					
		0.14 bar ΔP	0.27 bar ΔP	0.07 bar ΔP		0.14 bar ΔP		21°C Condensing		30°C Condensing		35°C Condensing	
				-10°C	-20°C	-10°C	-20°C	0.24 bar ΔP	0.34 bar ΔP	0.24 bar ΔP	0.34 bar ΔP	0.24 bar ΔP	0.34 bar ΔP
mm													
5	S6N	8.4	12	0.5	0.4	0.7	0.6	—	—	—	—	—	—
13	S8F SV2	38 —	52 58	2.4 —	1.9 —	3.4 —	2.6 —	— 12	— 14	— 13	— 16	— 14	— 17
20	S4A ④ S7A SV2	— 112 —	140 155 136	— 7.1 —	— 5.6 —	— 10 —	— 7.9 —	29 — 28	34 — 33	32 — 31	38 — 37	34 — 33	40 — 39
25	S4A S7A SV2	— 140 —	194 194 233	— 8.8 —	— 6.9 —	— 12 —	— 10 —	40 — 48	48 — 57	44 — 53	52 — 63	47 — 56	56 — 67
32	S4A S5A SV2	— 265 —	339 368 368	— 17 —	— 13 —	— 24 —	— 19 —	70 — 76	84 — 91	77 — 83	91 — 99	82 — 89	98 — 106
40	S4A S5A	466 516	647 717	— 33	— 26	42 46	33 36	134 —	160 —	147 —	174 —	157 —	187 —
50	S4A S5A	691 712	959 988	— 45	— 35	62 64	49 50	199 —	237 —	217 —	259 —	233 —	277 —
65	S4A S5A	977 1144	1357 1589	— 72	— 57	87 102	69 80	281 —	335 —	307 —	366 —	329 —	392 —
75	S4A S5A	1396 1605	1938 2229	— 100	— 80	125 144	98 113	402 —	478 —	439 —	522 —	470 —	560 —
100	S4A	2261	3140	—	—	202	159	651	774	711	846	762	907
125	S4W	—	—	—	—	—	—	803	956	878	1045	941	1119
150	S4W	—	—	—	—	—	—	1446	1721	1580	1880	1693	2015
200	S4W	—	—	—	—	—	—	2209	2629	2414	2873	2587	3079

All capacities are maximum for the conditions listed and have no reserve for excess loads.

- ① Liquid capacities for R134a are based on 40°C condensing and 5°C evaporator temperatures with no flashing through the valve for the pressure drops listed. For each 5°C liquid is below 40°C, INCREASE values by 5%.
- ② Suction capacities for R134a are based on 40°C liquid and 5°C superheat entering the valve at the pressure drops and evaporator temperatures listed. For each 5°C liquid is below 40°C, INCREASE values by 5%.
- ③ Hot gas heat reclaim capacities are in terms of heat of condensation rejected at the condenser and are based on saturated inlet conditions at pressures equivalent to the condensing temperatures and for the pressure drops listed.
- ④ The 20mm port size S4A is available with capacities equal to 50% of the ratings shown.

Solenoid Valves

R-134a (TONS)

Port Size	Type	Liquid Capacities ①		Suction Capacities ②				Hot Gas Reclaim ③					
		2 psi ΔP	4 psi ΔP	1 psi ΔP		2 psi ΔP		90°F Condensing		110°F Condensing		130°F Condensing	
				20°F	0°F	20°F	0°F	3.5 psi ΔP	5 psi ΔP	3.5 psi ΔP	5 psi ΔP	3.5 psi ΔP	5 psi ΔP
Inch													
3/16	S6N	2.4	3.4	0.2	0.1	0.2	0.2	—	—	—	—	—	—
1/2	S8F	11	15	0.7	0.6	1.1	0.8	—	—	—	—	—	—
	SV2	—	17	—	—	—	—	41	49	45	54	48	58
3/4	S4A ④	—	41	—	—	—	—	99	119	108	130	116	139
	S7A	32	46	2.2	1.7	3.1	2.4	—	—	—	—	—	—
	SV2	—	40	—	—	—	—	96	115	105	126	113	135
1	S4A	—	57	—	—	—	—	138	165	151	180	161	193
	S7A	40	57	2.8	2.1	3.9	3.0	—	—	—	—	—	—
	SV2	—	69	—	—	—	—	165	198	181	216	194	231
1 1/4	S4A	—	100	—	—	—	—	241	288	264	315	282	338
	S5A	77	109	5.2	4.0	7.4	5.7	—	—	—	—	—	—
	SV2	—	109	—	—	—	—	262	313	286	342	307	367
1 5/8	S4A	135	191	—	—	13	10	460	550	503	601	539	644
	S5A	149	211	10	8	14	11	—	—	—	—	—	—
2	S4A	200	283	—	—	19	15	682	815	745	891	799	955
	S5A	206	291	14	11	20	15	—	—	—	—	—	—
2 1/2	S4A	283	400	—	—	27	21	964	1153	1054	1260	1130	1350
	S5A	330	468	23	17	32	25	—	—	—	—	—	—
3	S4A	404	571	—	—	39	30	1378	1647	1506	1800	1614	1929
	S5A	464	657	32	24	45	35	—	—	—	—	—	—
4	S4A	654	925	—	—	63	49	2232	2668	2440	2916	2615	3125
5	S4W	—	—	—	—	—	—	2756	3294	3012	3600	3228	3858
6	S4W	—	—	—	—	—	—	4960	5929	5422	6480	5810	6944
8	S4W	—	—	—	—	—	—	7578	9058	8283	9900	8876	10609

All capacities are maximum for the conditions listed and have no reserve for excess loads.

- ① Liquid capacities for R134a are based on 100°F condensing and 40°F evaporator temperatures with no flashing through the valve for the pressure drops listed. For each 40°F liquid is below 100°F, INCREASE values by 5%.
- ② Suction capacities for R134a are based on 100°F liquid and 40°F superheat entering the valve at the pressure drops and evaporator temperatures listed. For each 10°F liquid is below 100°F, INCREASE values by 5%.
- ③ Hot gas heat reclaim capacities are in terms of heat of condensation rejected at the condenser and are based on saturated inlet conditions at pressures equivalent to the condensing temperatures and for the pressure drops listed.
- ④ The 3/4" port size S4A is available with capacities equal to 50% of the ratings shown.

Solenoid Valves

R-404a (KW)

Port Size	Type	Liquid Capacities ①		Suction Capacities ②				Hot Gas Reclaim ③					
		0.14 bar ΔP	0.27 bar ΔP	0.07 bar ΔP		0.14 bar ΔP		21°C Condensing		30°C Condensing		35°C Condensing	
				-10°C	-20°C	-10°C	-20°C	0.24 bar ΔP	0.34 bar ΔP	0.24 bar ΔP	0.34 bar ΔP	0.24 bar ΔP	0.34 bar ΔP
mm													
5	S6N	5.7	7.9	0.6	0.5	0.8	0.7	—	—	—	—	—	—
13	S8F SV2	26 —	36 40	2.6 —	2.1 —	3.7 —	3.0 —	— 13	— 16	— 14	— 16	— 13	— 16
20	S4A ④ S7A SV2	— 76 —	95 106 93	— 7.8 —	— 6.2 —	— 11 —	— 8.7 —	32 — 31	38 — 36	33 — 32	39 — 38	32 — 31	38 — 37
25	S4A S7A SV2	— 95 —	132 132 159	— 9.7 —	— 7.7 —	— 14 —	— 11 —	44 — 53	52 — 63	45 — 54	54 — 65	45 — 53	53 — 64
32	S4A S5A SV2	— 181 —	232 252 252	— 19 —	— 15 —	— 26 —	— 21 —	77 — 83	91 — 99	79 — 86	94 — 103	78 — 85	93 — 101
40	S4A S5A	318 353	442 490	— 36	— 29	46 51	37 40	146 —	174 —	151 —	180 —	149 —	177 —
50	S4A S5A	472 486	655 675	— 50	— 39	68 70	54 56	217 —	258 —	224 —	267 —	220 —	262 —
65	S4A S5A	667 782	927 1086	— 80	— 63	96 113	77 90	307 —	365 —	317 —	378 —	312 —	371 —
75	S4A S5A	954 1097	1324 1523	— 110	— 89	138 158	109 126	438 —	521 —	453 —	540 —	445 —	530 —
100	S4A	1545	2145	—	—	223	178	710	845	734	874	721	858
125	S4W	—	—	—	—	—	—	876	1043	907	1079	890	1060
150	S4W	—	—	—	—	—	—	1577	1877	1632	1942	1603	1908
200	S4W	—	—	—	—	—	—	2409	2868	2493	2967	2449	2915

All capacities are maximum for the conditions listed and have no reserve for excess loads.

- ① Liquid capacities for R404a are based on 40°C condensing and 5°C evaporator temperatures with no flashing through the valve for the pressure drops listed. For each 5°C liquid is below 40°C, INCREASE values by 5%.
- ② Suction capacities for R404a are based on 40°C liquid and 5°C superheat entering the valve at the pressure drops and evaporator temperatures listed. For each 5°C liquid is below 40°C, INCREASE values by 5%.
- ③ Hot gas heat reclaim capacities are in terms of heat of condensation rejected at the condenser and are based on saturated inlet conditions at pressures equivalent to the condensing temperatures and for the pressure drops listed.
- ④ The 20mm port size S4A is available with capacities equal to 50% of the ratings shown.

Solenoid Valves

R-404a (TONS)

Port Size	Type	Liquid Capacities ①		Suction Capacities ②				Hot Gas Reclaim ③					
		2 psi ΔP	4 psi ΔP	1 psi ΔP		2 psi ΔP		90°F Condensing		110°F Condensing		130°F Condensing	
				20°F	0°F	20°F	0°F	3.5 psi ΔP	5 psi ΔP	3.5 psi ΔP	5 psi ΔP	3.5 psi ΔP	5 psi ΔP
Inch													
3/16	S6N	1.7	2.4	0.2	0.1	0.3	0.2	—	—	—	—	—	—
1/2	S8F	7.6	11	0.8	0.6	1.2	0.9	—	—	—	—	—	—
	SV2	—	12	—	—	—	—	45	54	47	56	46	55
3/4	S4A ④	—	28	—	—	—	—	108	129	112	134	109	131
	S7A	22	32	2.5	1.9	3.5	2.7	—	—	—	—	—	—
	SV2	—	28	—	—	—	—	105	126	109	130	106	127
1	S4A	—	40	—	—	—	—	150	179	155	186	152	182
	S7A	28	40	3.1	2.4	4.3	3.4	—	—	—	—	—	—
	SV2	—	47	—	—	—	—	180	215	186	223	182	218
1 1/4	S4A	—	69	—	—	—	—	263	314	272	325	266	318
	S5A	53	75	5.8	4.5	8.3	6.4	—	—	—	—	—	—
	SV2	—	75	—	—	—	—	285	341	295	353	289	345
1 5/8	S4A	93	132	—	—	15	11	501	599	519	620	508	607
	S5A	103	146	11	9	16	13	—	—	—	—	—	—
2	S4A	140	196	—	—	22	17	743	888	769	919	753	900
	S5A	143	202	16	12	22	17	—	—	—	—	—	—
2 1/2	S4A	196	277	—	—	30	24	1051	1256	1087	1299	1064	1272
	S5A	230	324	25	20	36	28	—	—	—	—	—	—
3	S4A	280	396	—	—	43	34	1501	1794	1553	1856	1520	1817
	S5A	322	455	35	28	50	39	—	—	—	—	—	—
4	S4A	453	641	—	—	71	55	2432	2907	2515	3006	2463	2944
5	S4W	—	—	—	—	—	—	3003	3589	3105	3711	3041	3635
6	S4W	—	—	—	—	—	—	5405	6460	5589	6680	5474	6542
8	S4W	—	—	—	—	—	—	8257	9869	8539	10206	8363	9995

All capacities are maximum for the conditions listed and have no reserve for excess loads.

① Liquid capacities for R404a are based on 100°F condensing and 40°F evaporator temperatures with no flashing through the valve for the pressure drops listed. For each 40°F liquid is below 100°F, INCREASE values by 5%.

② Suction capacities for R404a are based on 100°F liquid and 40°F superheat entering the valve at the pressure drops and evaporator temperatures listed. For each 10°F liquid is below 100°F, INCREASE values by 5%.

③ Hot gas heat reclaim capacities are in terms of heat of condensation rejected at the condenser and are based on saturated inlet conditions at pressures equivalent to the condensing temperatures and for the pressure drops listed.

④ The 3/4" port size S4A is available with capacities equal to 50% of the ratings shown.

Solenoid Valves

R-410a (KW)

Port Size	Type	Liquid Capacities ①		Suction Capacities ②				Hot Gas Reclaim ③					
		0.14 bar ΔP	0.27 bar ΔP	0.07 bar ΔP		0.14 bar ΔP		21°C Condensing		30°C Condensing		35°C Condensing	
				-10°C	-20°C	-10°C	-20°C	0.24 bar ΔP	0.34 bar ΔP	0.24 bar ΔP	0.34 bar ΔP	0.24 bar ΔP	0.34 bar ΔP
mm													
5	S6N	8.3	12	0.9	0.7	1.2	1.0	—	—	—	—	—	—
13	S8F SV2	37 —	52 58	3.9 —	3.2 —	5.5 —	4.5 —	— 18	— 21	— 18	— 22	— 18	— 21
20	S4A ④ S7A SV2	— 111 —	139 154 135	— 12 —	— 9.5 —	— 16 —	— 13 —	42 — 41	50 — 49	43 — 42	52 — 50	42 — 41	51 — 49
25	S4A S7A SV2	— 139 —	193 193 231	— 15 —	— 12 —	— 21 —	— 17 —	58 — 70	70 — 83	60 — 72	72 — 86	59 — 71	70 — 84
32	S4A S5A SV2	— 264 —	337 366 366	— 28 —	— 23 —	— 39 —	— 32 —	102 — 111	122 — 132	106 — 115	126 — 137	103 — 112	123 — 133
40	S4A S5A	463 513	644 713	— 54	— 44	69 76	56 62	195 —	232 —	202 —	240 —	197 —	235 —
50	S4A S5A	687 708	954 983	— 74	— 60	102 105	83 85	289 —	344 —	299 —	356 —	292 —	348 —
65	S4A S5A	971 1138	1349 1580	— 119	— 97	144 168	117 137	409 —	487 —	423 —	503 —	413 —	491 —
75	S4A S5A	1387 1596	1927 2216	— 170	— 136	205 236	168 193	585 —	696 —	604 —	718 —	590 —	702 —
100	S4A	2248	3121	—	—	331	271	947	1127	978	1164	956	1137
125	S4W	—	—	—	—	—	—	1169	1392	1207	1437	1180	1404
150	S4W	—	—	—	—	—	—	2104	2505	2173	2586	2124	2528
200	S4W	—	—	—	—	—	—	3215	3827	3320	3951	3244	3862

All capacities are maximum for the conditions listed and have no reserve for excess loads.

- ① Liquid capacities for R410a are based on 40°C condensing and 5°C evaporator temperatures with no flashing through the valve for the pressure drops listed. For each 5°C liquid is below 40°C, INCREASE values by 5%.
- ② Suction capacities for R410a are based on 40°C liquid and 5°C superheat entering the valve at the pressure drops and evaporator temperatures listed. For each 5°C liquid is below 40°C, INCREASE values by 5%.
- ③ Hot gas heat reclaim capacities are in terms of heat of condensation rejected at the condenser and are based on saturated inlet conditions at pressures equivalent to the condensing temperatures and for the pressure drops listed.
- ④ The 20mm port size S4A is available with capacities equal to 50% of the ratings shown.

Solenoid Valves

R-410a (TONS)

Port Size	Type	Liquid Capacities ①		Suction Capacities ②				Hot Gas Reclaim ③					
		2 psi ΔP	4 psi ΔP	1 psi ΔP		2 psi ΔP		90°F Condensing		110°F Condensing		130°F Condensing	
				20°F	0°F	20°F	0°F	3.5 psi ΔP	5 psi ΔP	3.5 psi ΔP	5 psi ΔP	3.5 psi ΔP	5 psi ΔP
Inch													
3/16	S6N	2.4	3.4	0.3	0.2	0.4	0.3	—	—	—	—	—	—
1/2	S8F	11	15	1.2	1.0	1.7	1.4	—	—	—	—	—	—
	SV2	—	17	—	—	—	—	60	72	62	74	60	72
3/4	S4A ④	—	41	—	—	—	—	144	172	149	178	145	173
	S7A	32	46	3.6	2.9	5.1	4.1	—	—	—	—	—	—
	SV2	—	40	—	—	—	—	140	168	145	173	141	168
1	S4A	—	57	—	—	—	—	200	239	207	247	201	241
	S7A	40	57	4.5	3.6	6.4	5.1	—	—	—	—	—	—
	SV2	—	69	—	—	—	—	240	287	248	296	242	289
1 1/4	S4A	—	100	—	—	—	—	351	419	362	432	352	421
	S5A	77	109	8.5	6.9	12	9.7	—	—	—	—	—	—
	SV2	—	109	—	—	—	—	381	455	393	469	383	457
1 5/8	S4A	135	191	—	—	21	17	669	800	690	825	673	804
	S5A	150	212	17	13	24	19	—	—	—	—	—	—
2	S4A	200	283	—	—	31	25	992	1185	1023	1223	997	1191
	S5A	206	292	23	18	32	26	—	—	—	—	—	—
2 1/2	S4A	283	400	—	—	44	36	1402	1676	1447	1730	1410	1685
	S5A	330	469	37	30	52	42	—	—	—	—	—	—
3	S4A	404	572	—	—	64	51	2003	2395	2067	2471	2014	2407
	S5A	465	658	52	41	73	59	—	—	—	—	—	—
4	S4A	655	927	—	—	102	82	3246	3879	3349	4003	3262	3899
5	S4W	—	—	—	—	—	—	4007	4789	4134	4942	4028	4814
6	S4W	—	—	—	—	—	—	7212	8621	7442	8895	7250	8665
8	S4W	—	—	—	—	—	—	11019	13170	11370	13589	11076	13238

All capacities are maximum for the conditions listed and have no reserve for excess loads.

- ① Liquid capacities for R410a are based on 100°F condensing and 40°F evaporator temperatures with no flashing through the valve for the pressure drops listed. For each 40°F liquid is below 100°F, INCREASE values by 5%.
- ② Suction capacities for R410a are based on 100°F liquid and 40°F superheat entering the valve at the pressure drops and evaporator temperatures listed. For each 10°F liquid is below 100°F, INCREASE values by 5%.
- ③ Hot gas heat reclaim capacities are in terms of heat of condensation rejected at the condenser and are based on saturated inlet conditions at pressures equivalent to the condensing temperatures and for the pressure drops listed.
- ④ The 3/4" port size S4A is available with capacities equal to 50% of the ratings shown.

Solenoid Valves

R-507a (KW)

Port Size	Type	Liquid Capacities ①		Suction Capacities ②				Hot Gas Reclaim ③					
		0.14 bar ΔP	0.27 bar ΔP	0.07 bar ΔP		0.14 bar ΔP		21°C Condensing		30°C Condensing		35°C Condensing	
				-10°C	-20°C	-10°C	-20°C	0.24 bar ΔP	0.34 bar ΔP	0.24 bar ΔP	0.34 bar ΔP	0.24 bar ΔP	0.34 bar ΔP
mm													
5	S6N	5.5	7.7	0.6	0.5	0.8	0.7	—	—	—	—	—	—
13	S8F SV2	25 —	35 38	2.6 —	2.1 —	3.7 —	2.9 —	— 13	— 16	— 13	— 16	— 13	— 16
20	S4A ④ S7A SV2	— 74 —	92 103 90	— 7.8 —	— 6.2 —	— 11 —	— 8.7 —	31 — 31	37 — 36	32 — 31	39 — 37	31 — 31	37 — 36
25	S4A S7A SV2	— 92 —	128 128 154	— 10 —	— 7.7 —	— 14 —	— 11 —	44 — 52	52 — 62	45 — 54	54 — 64	44 — 52	52 — 62
32	S4A S5A SV2	— 175 —	224 243 243	— 18 —	— 15 —	— 26 —	— 21 —	76 — 83	91 — 99	79 — 85	94 — 102	76 — 83	91 — 99
40	S4A S5A	308 341	428 474	— 36	— 29	46 51	36 40	146 —	174 —	150 —	179 —	146 —	174 —
50	S4A S5A	457 471	634 654	— 49	— 39	68 70	54 56	216 —	257 —	223 —	265 —	216 —	258 —
65	S4A S5A	646 757	897 1051	— 80	— 63	96 113	76 89	306 —	364 —	315 —	375 —	306 —	364 —
75	S4A S5A	923 1061	1281 1474	— 110	— 89	137 158	109 125	437 —	520 —	450 —	535 —	437 —	520 —
100	S4A	1495	2076	—	—	222	176	708	842	728	867	708	843
125	S4W	—	—	—	—	—	—	874	1040	899	1070	874	1040
150	S4W	—	—	—	—	—	—	1572	1872	1619	1927	1573	1873
200	S4W	—	—	—	—	—	—	2402	2859	2473	2944	2404	2861

All capacities are maximum for the conditions listed and have no reserve for excess loads.

- ① Liquid capacities for R507a are based on 40°C condensing and 5°C evaporator temperatures with no flashing through the valve for the pressure drops listed. For each 5°C liquid is below 40°C, INCREASE values by 5%.
- ② Suction capacities for R507a are based on 40°C liquid and 5°C superheat entering the valve at the pressure drops and evaporator temperatures listed. For each 5°C liquid is below 40°C, INCREASE values by 5%.
- ③ Hot gas heat reclaim capacities are in terms of heat of condensation rejected at the condenser and are based on saturated inlet conditions at pressures equivalent to the condensing temperatures and for the pressure drops listed.
- ④ The 20mm port size S4A is available with capacities equal to 50% of the ratings shown.

Solenoid Valves

R-507a (TONS)

Port Size	Type	Liquid Capacities ①		Suction Capacities ②				Hot Gas Reclaim ③					
		2 psi ΔP	4 psi ΔP	1 psi ΔP		2 psi ΔP		90°F Condensing		110°F Condensing		130°F Condensing	
				20°F	0°F	20°F	0°F	3.5 psi ΔP	5 psi ΔP	3.5 psi ΔP	5 psi ΔP	3.5 psi ΔP	5 psi ΔP
Inch													
3/16	S6N	1.6	2.3	0.2	0.1	0.3	0.2	—	—	—	—	—	—
1/2	S8F	7.3	10	0.8	0.6	1.2	0.9	—	—	—	—	—	—
	SV2	—	11	—	—	—	—	45	54	46	55	45	53
3/4	S4A ④	—	28	—	—	—	—	108	129	111	133	107	128
	S7A	22	31	2.4	1.9	3.5	2.7	—	—	—	—	—	—
	SV2	—	27	—	—	—	—	105	125	108	129	104	125
1	S4A	—	38	—	—	—	—	150	179	154	184	149	178
	S7A	27	38	3.1	2.4	4.3	3.4	—	—	—	—	—	—
	SV2	—	46	—	—	—	—	180	215	185	221	179	214
1 1/4	S4A	—	67	—	—	—	—	262	313	269	322	261	312
	S5A	51	73	5.8	4.5	8.2	6.4	—	—	—	—	—	—
	SV2	—	73	—	—	—	—	284	340	293	350	283	339
1 5/8	S4A	91	128	—	—	14	11	500	598	514	615	498	595
	S5A	100	142	11	9	16	12	—	—	—	—	—	—
2	S4A	130	190	—	—	21	17	741	886	762	911	738	882
	S5A	138	195	16	12	22	17	—	—	—	—	—	—
2 1/2	S4A	190	268	—	—	30	24	1048	1252	1078	1288	1044	1248
	S5A	220	314	25	20	36	28	—	—	—	—	—	—
3	S4A	271	383	—	—	43	34	1497	1789	1540	1841	1492	1783
	S5A	312	441	35	27	50	39	—	—	—	—	—	—
4	S4A	439	621	—	—	70	55	2425	2898	2495	2982	2416	2888
5	S4W	—	—	—	—	—	—	2994	3578	3080	3681	2983	3566
6	S4W	—	—	—	—	—	—	5389	6441	5544	6626	5370	6418
8	S4W	—	—	—	—	—	—	8233	9840	8469	10123	8204	9805

All capacities are maximum for the conditions listed and have no reserve for excess loads.

- ① Liquid capacities for R507a are based on 100°F condensing and 40°F evaporator temperatures with no flashing through the valve for the pressure drops listed. For each 40°F liquid is below 100°F, INCREASE values by 5%.
- ② Suction capacities for R507a are based on 100°F liquid and 40°F superheat entering the valve at the pressure drops and evaporator temperatures listed. For each 10°F liquid is below 100°F, INCREASE values by 5%.
- ③ Hot gas heat reclaim capacities are in terms of heat of condensation rejected at the condenser and are based on saturated inlet conditions at pressures equivalent to the condensing temperatures and for the pressure drops listed.
- ④ The 3/4" port size S4A is available with capacities equal to 50% of the ratings shown.

Gas Powered Valves

The CK-2 and CK-5, normally open, gas powered suction stop valves are uniquely constructed to use discharge pressure to close. These valves are typically used for low temperature applications in wet return lines on liquid recirculation systems or on the liquid and gas return legs of flooded evaporators. Due to its normally open construction, pressure drop is minimal in suction or wet return applications. In addition, normal gravity circulation is unrestricted on flooded evaporators. For gravity flooded evaporators, both valves should be installed with their flow arrows pointing towards the surge drum. Being pressure powered to close, this valve can overcome sticking at low temperatures caused by the presence of viscous oil.

Unlike the CK-2, the CK-5 is designed to remain in a closed position in the event that power to the pilot solenoid is inadvertently interrupted (i.e. a power failure), during hot gas defrost. This prevents a “suction shock” condition under these circumstances.

The S9A, normally closed, gas powered suction stop valve is a pilot operated valve but uses an external source of higher pressure gas to operate the valve, and, therefore requires no minimum pressure drop to open. The external gas pressure for the Type S9A must be at least 0.69 bar (10 psi) above valve internal upstream pressure for positive opening. This valve is normally closed.

The S9A valve is designed to promptly and fully open or close under conditions which make conventional solenoid valves unreliable or unsuitable, such as viscous oil conditions, location in a vertical pipeline, or where very low valve pressure drop is required. This valve is a two-position valve using condenser gas pressure acting upon a piston for opening, and a strong spring for closing. A twin pilot solenoid valve assembly (S9) serves to admit condenser gas pressure to the piston for opening and to bleed this gas pressure to the suction line for valve closing.

Specifications

Temperature Range -50°C to 105°C (-60°F to 220°F)
 Maximum Rated Pressure (MRP) 27.6 barg (400 psig)

DIN Specifications

Temperature Range -50°C to 105°C (-60°F to 220°F)
 Maximum Rated Pressure (MRP) 28 barg (406 psig)

*For more specifications see below table

Gas Powered



Specifications

Port Size		Type	Seat Material	Standard Body Material	*DIN Body Material	Minimum Pressure Drop to Open		Minimum Pressure Drop to Close		Operation	Bulletin
mm	inch					bar	psi	bar	psi		
32	1¼	CK-2	PTFE	Gray Iron	GGG-40.3	0	0	0.35	5	Normally Open	50-12
40 - 100	1½ - 4	CK-2	Metal	Gray Iron	GGG-40.3	0	0	0.35	5	Normally Open	50-12
125 - 150	5 - 6	CK-2	Metal	Gray Iron	-	0	0	0.35	5	Normally Open	50-12
32	1¼	CK-5	PTFE	Gray Iron	GGG-40.3	0	0	0.35	5	Normally Open	50-23
40 - 100	1½ - 4	CK-5	Metal	Gray Iron	GGG-40.3	0	0	0.35	5	Normally Open	50-23
125 - 150	5 - 6	CK-5	Metal	Gray Iron	-	0	0	0.35	5	Normally Open	50-23
50 - 100	2 - 4	S9A	Metal	Gray Iron	-	0.69	10	0	0	Normally Closed	31-90
125 - 200	5 - 8	S9W	Metal	Gray Iron	-	0.69	10	0	0	Normally Closed	30-05

*Complies with Pressure Equipment Directive 97/23/EC

Gas Powered Valves



Application Guide

Refrigerant Application	Refrigerant Temperature Range	Operation	Valve Recommendation - Listed by Port Size								
			32mm	40mm	50mm	65mm	75mm	100mm	125mm	150mm	200mm
			1 1/4"	1 5/8"	2"	2 1/2"	3"	4"	5"	6"	8"
Suction	Above -50°C (-60°F)	Normally Open	CK-2 CK-5	CK-2A CK-5	CK-2 CK-5	CK-2 CK-5	CK-2 CK-5	CK-2 CK-5	CK-2 CK-5	CK-2 CK-5	— —
	Above -45°C (-50°F)	Normally Closed	—	—	S9A	S9A	S9A	S9A	S9W	S9W	S9W

Recommendations assume no highly viscous oil, dirt, moisture or foreign substance in refrigerant; also no abnormal shock impact below -30°C (-25°F). Use CK-2 only above -30°C (-25°F) if not powered by near oil free hot gas such as in rotary screw compressor systems.

General Information

Port Size		Type	Description	Flow Coefficient		Connections Available			Pilot Solenoid
mm	inch			Kv	Cv	FPT, SW, WN	ODS	WN (DN)	
32	1 1/4"	CK-2	Normally Open	16	19	1 1/4", 1 1/2"	1 5/8"	32	S6N (1)
		CK-5	Normally Open	16	19				*S6B or S6A (1)
40	1 5/8"	CK-2	Normally Open	32	37	1 1/2", 2"	2 1/8", 2 5/8"	38, 50	S6N (1)
		CK-5	Normally Open	32	37				*S6B or S6A (1)
50	2"	S9A	Normally Closed	39	45	1 1/2", 2"	2 1/8", 2 5/8"	38, 50	S6N (2)
		CK-2	Normally Open	44	51				S6N (1)
		CK-5	Normally Open	44	51				*S6B or S6A (1)
65	2 1/2"	S9A	Normally Closed	56	65	2 1/2", 3" (No FPT)	2 5/8", 3 1/8"	65	S6N (2)
		CK-2	Normally Open	70	82				S6N (1)
		CK-5	Normally Open	70	82				*S6B or S6A (1)
75	3"	S9A	Normally Closed	86	100	3" (No FPT)	3 1/8", 3 5/8"	75	S6N (2)
		CK-2	Normally Open	103	120				S6N (1)
		CK-5	Normally Open	103	120				*S6B or S6A (1)
100	4"	S9A	Normally Closed	154	180	4" (No FPT)	4 1/8"	100	S6N (2)
		CK-2	Normally Open	171	200				S6N (1)
		CK-5	Normally Open	171	200				*S6B or S6A (1)
125	5"	S9W	Normally Closed	171	200	WN only			S6N (2)
		CK-2	Normally Open	244	285	5" (No FPT)	N.A.	N.A.	S8F (1)
		CK-5	Normally Open	244	285				S8F (1)
150	6"	S9W	Normally Closed	308	360	WN only			S6N (2)
		CK-2	Normally Open	342	400	6" (No FPT)	N.A.	N.A.	S8F (1)
		CK-5	Normally Open	342	400				S8F (1)
200	8"	S9W	Normally Closed	471	550	WN only			S6N (2)

* Valve containing S6B coils can be installed in a vertical or horizontal position

Gas Powered

Suction Capacities - CK-2/CK-5

R-717 (KW)

Evap. Temp (°C)	Evap. Pressure (barg)	ΔP (bar)	Port Size							
			32mm	40mm	50mm	65mm	75mm	100mm	125mm	150mm
-10	1.89	0.035	52	101	139	223	327	545	777	1090
		0.017	37	71	98	158	231	385	549	771
-20	0.89	0.035	42	83	114	183	268	446	636	892
		0.017	30	58	80	129	189	315	449	631
-35 ①	-0.08	0.035	34	66	91	146	213	356	507	712
		0.017	24	47	64	103	151	252	358	503
-45 ①	-0.47	0.035	26	51	70	113	165	276	393	551
		0.017	19	36	50	80	117	195	278	390

R-717 (TONS)

Evap. Temp (°F)	Evap. Pressure (psig)	ΔP (psi)	Port Size							
			1¼"	1½"	2"	2½"	3"	4"	5"	6"
10	23.8	0.50	15	29	40	64	93	155	221	310
		0.25	10	20	28	45	66	110	156	219
-10	9.0	0.50	12	23	33	52	76	127	181	254
		0.25	8.5	17	23	37	54	90	128	179
-30 ①	1.6 in Hg	0.50	9.6	19	26	41	61	101	144	202
		0.25	6.8	13	18	29	43	72	102	143
-50 ①	14.3 in Hg	0.50	7.4	14	20	32	47	78	112	157
		0.25	5.3	10	14	23	33	55	79	111

R-22 (KW)

Evap. Temp (°C)	Evap. Pressure (barg)	ΔP (bar)	Port Size							
			32mm	40mm	50mm	65mm	75mm	100mm	125mm	150mm
-10	2.53	0.035	22	42	58	93	137	228	325	456
		0.017	15	30	41	66	97	161	230	322
-20	1.44	0.035	18	36	49	79	116	194	276	387
		0.017	13	25	35	56	82	137	195	274
-35 ①	0.31	0.035	15	30	41	66	97	161	229	322
		0.017	11	21	29	47	68	114	162	228
-45 ①	-0.18	0.035	12	24	33	53	78	130	186	260
		0.017	8.7	17	23	38	55	92	131	184

R-22 (TONS)

Evap. Temp (°F)	Evap. Pressure (psig)	ΔP (psi)	Port Size							
			1¼"	1½"	2"	2½"	3"	4"	5"	6"
10	32.8	0.50	6.2	12	17	27	39	65	92	130
		0.25	4.4	8.5	12	19	28	46	65	92
-10	16.5	0.50	5.2	10	14	23	33	55	79	110
		0.25	3.7	7.2	9.9	16	23	39	56	78
-30 ①	4.9	0.50	4.3	8.5	12	19	27	46	65	92
		0.25	3.1	6.0	8.3	13	19	32	46	65
-50 ①	6.1 in Hg	0.50	3.5	6.9	9.4	15	22	37	53	74
		0.25	2.5	4.8	6.7	11	16	26	37	52

Capacities are based on liquid temperatures equal to evaporator temperatures. For liquid overfeed systems, nominal 2:1 to 5:1 ratio, add 20% to the evaporator load and select a valve based on the increased load.

① The CK2 may be used at these temperatures if it is powered by nearly oil free hot gas (such as in rotary screw compressor systems). If the gas is not nearly oil free, use the CK2 only at temperatures above -30°C (-25°F).

Suction Capacities - CK-2/CK-5

R-134a (KW)

Evap. Temp (°C)	Evap. Pressure (barg)	ΔP (bar)	Port Size							
			32mm	40mm	50mm	65mm	75mm	100mm	125mm	150mm
-10	0.99	0.035	17	33	45	73	107	178	253	356
		0.017	12	23	32	52	75	126	179	252
-20	0.31	0.035	14	27	38	60	89	148	210	295
		0.017	9.9	19	27	43	63	104	149	209
-35 ①	-0.35	0.035	11	22	30	49	72	119	170	239
		0.017	8.0	16	22	35	51	84	120	169
-45 ①	-0.62	0.035	8.9	17	24	38	56	94	133	187
		0.017	6.3	12	17	27	40	66	94	132

R-134a (TONS)

Evap. Temp (°F)	Evap. Pressure (psig)	ΔP (psi)	Port Size							
			1¼"	1½"	2"	2½"	3"	4"	5"	6"
10	11.9	0.50	4.8	9.4	13	21	30	51	72	101
		0.25	3.4	6.6	9.1	15	21	36	51	72
-10	1.9	0.50	4.0	7.8	11	17	25	42	60	84
		0.25	2.8	5.5	7.6	12	18	30	42	59
-30 ①	9.8 in Hg	0.50	3.2	6.3	8.6	14	20	34	48	68
		0.25	2.3	4.4	6.1	9.8	14	24	34	48
-50 ①	18.7 in Hg	0.50	2.5	4.9	6.8	11	16	27	38	53
		0.25	1.8	3.5	4.8	7.7	11	19	27	38

R-404a (KW)

Evap. Temp (°C)	Evap. Pressure (barg)	ΔP (bar)	Port Size							
			32mm	40mm	50mm	65mm	75mm	100mm	125mm	150mm
-10	3.38	0.035	21	41	57	92	134	224	319	448
		0.017	15	29	40	65	95	158	226	317
-20	2.06	0.035	18	36	49	79	115	192	274	385
		0.017	13	25	35	56	82	136	194	272
-35 ①	0.67	0.035	15	30	41	66	97	161	230	323
		0.017	11	21	29	47	68	114	163	228
-45 ①	0.06	0.035	13	24	34	54	79	132	188	264
		0.017	8.9	17	24	38	56	93	133	187

R-404a (TONS)

Evap. Temp (°F)	Evap. Pressure (psig)	ΔP (psi)	Port Size							
			1¼"	1½"	2"	2½"	3"	4"	5"	6"
10	44.3	0.50	6.0	12	16	26	38	64	91	127
		0.25	4.3	8.3	11	18	27	45	64	90
-10	24.6	0.50	5.2	10	14	22	33	55	78	109
		0.25	3.7	7.2	9.9	16	23	39	55	77
-30 ①	10.3	0.50	4.4	8.5	12	19	28	46	65	92
		0.25	3.1	6.0	8.3	13	19	32	46	65
-50 ①	0.5	0.50	3.6	6.9	9.6	15	23	38	53	75
		0.25	2.5	4.9	6.8	11	16	27	38	53

Capacities are based on liquid temperatures equal to evaporator temperatures. For liquid overfeed systems, nominal 2:1 to 5:1 ratio, add 20% to the evaporator load and select a valve based on the increased load.

① The CK2 may be used at these temperatures if it is powered by nearly oil free hot gas (such as in rotary screw compressor systems). If the gas is not nearly oil free, use the CK2 only at temperatures above -30°C (-25°F).

Gas Powered

Suction Capacities - CK-2/CK-5

R-410a (KW)

Evap. Temp (°C)	Evap. Pressure (barg)	ΔP (bar)	Port Size							
			32mm	40mm	50mm	65mm	75mm	100mm	125mm	150mm
-10	4.73	0.035	28	55	76	123	180	299	427	599
		0.017	20	39	54	87	127	212	302	423
-20	2.99	0.035	24	48	66	105	154	257	367	515
		0.017	17	34	46	75	109	182	259	364
-35 ①	1.18	0.035	21	40	55	89	130	216	308	432
		0.017	15	28	39	63	92	153	218	306
-45 ①	0.38	0.035	17	33	45	72	106	177	252	353
		0.017	12	23	32	51	75	125	178	250

R-410a (TONS)

Evap. Temp (°F)	Evap. Pressure (psig)	ΔP (psi)	Port Size							
			1¼"	1⅝"	2"	2½"	3"	4"	5"	6"
10	62.4	0.50	8.1	16	22	35	51	85	121	170
		0.25	5.7	11	15	25	36	60	86	120
-10	36.5	0.50	7.0	14	19	30	44	73	104	146
		0.25	4.9	9.6	13	21	31	52	74	103
-30 ①	17.8	0.50	5.8	11	16	25	37	61	88	123
		0.25	4.1	8.0	11	18	26	43	62	87
-50 ①	5.0	0.50	4.8	9.3	13	21	30	50	72	101
		0.25	3.4	6.6	9.1	15	21	36	51	71

R-507a (KW)

Evap. Temp (°C)	Evap. Pressure (barg)	ΔP (bar)	Port Size							
			32mm	40mm	50mm	65mm	75mm	100mm	125mm	150mm
-10	3.48	0.035	21	42	58	93	135	226	322	452
		0.017	15	30	41	65	96	160	228	319
-20	2.13	0.035	18	36	50	80	117	195	277	389
		0.017	13	25	35	56	83	138	196	275
-35 ①	0.71	0.035	16	30	42	67	98	164	233	328
		0.017	11	21	30	47	69	116	165	232
-45 ①	0.09	0.035	13	25	34	55	81	134	191	269
		0.017	9.0	18	24	39	57	95	135	190

R-507a (TONS)

Evap. Temp (°F)	Evap. Pressure (psig)	ΔP (psi)	Port Size							
			1¼"	1⅝"	2"	2½"	3"	4"	5"	6"
10	45.7	0.50	6.1	12	16	26	39	64	91	128
		0.25	4.3	8.4	12	19	27	45	65	91
-10	25.5	0.50	5.3	10	14	23	33	55	79	111
		0.25	3.7	7.2	10	16	23	39	56	78
-30 ①	11.0	0.50	4.4	8.6	12	19	28	47	66	93
		0.25	3.1	6.1	8.4	14	20	33	47	66
-50 ①	3.0	0.50	3.6	7.1	9.7	16	23	38	54	76
		0.25	2.6	5.0	6.9	11	16	27	38	54

Capacities are based on liquid temperatures equal to evaporator temperatures. For liquid overfeed systems, nominal 2:1 to 5:1 ratio, add 20% to the evaporator load and select a valve based on the increased load.

① The CK2 may be used at these temperatures if it is powered by nearly oil free hot gas (such as in rotary screw compressor systems). If the gas is not nearly oil free, use the CK2 only at temperatures above -30°C (-25°F).

Suction Capacities - S9A/S9W

R-717 (KW)

Evap. Temp (°C)	Evap. Pressure (barg)	ΔP (bar)	Port Size						
			50mm	65mm	75mm	100mm	125mm	150mm	200mm
-10	1.89	0.035	123	177	272	490	545	981	1499
		0.017	87	125	193	347	385	694	1060
-20	0.89	0.035	100	145	223	401	446	803	1226
		0.017	71	102	158	284	315	568	867
-35	<i>-0.08</i>	0.035	80	116	178	320	356	640	978
		0.017	57	82	126	226	252	453	692
-45	<i>-0.47</i>	0.035	62	90	138	248	276	496	758
		0.017	44	63	97	175	195	351	536

R-717 (TONS)

Evap. Temp (°F)	Evap. Pressure (psig)	ΔP (psi)	Port Size						
			2"	2½"	3"	4"	5"	6"	8"
10	23.8	0.50	35	50	77	139	155	279	426
		0.25	25	36	55	99	110	197	301
-10	9.0	0.50	29	41	63	114	127	228	349
		0.25	20	29	45	81	90	161	247
-30	<i>1.6 in Hg</i>	0.50	23	33	51	91	101	182	278
		0.25	16	23	36	64	72	129	197
-50	<i>14.3 in Hg</i>	0.50	18	25	39	71	78	141	215
		0.25	12	18	28	50	55	100	152

R-22 (KW)

Evap. Temp (°C)	Evap. Pressure (barg)	ΔP (bar)	Port Size						
			50mm	65mm	75mm	100mm	125mm	150mm	200mm
-10	2.53	0.035	51	74	114	205	228	410	627
		0.017	36	52	81	145	161	290	443
-20	1.44	0.035	44	63	97	174	194	349	533
		0.017	31	45	68	123	137	247	377
-35	0.31	0.035	36	52	80	145	161	290	443
		0.017	26	37	57	102	114	205	313
-45	<i>-0.18</i>	0.035	29	42	65	117	130	234	358
		0.017	21	30	46	83	92	166	253

R-22 (TONS)

Evap. Temp (°F)	Evap. Pressure (psig)	ΔP (psi)	Port Size						
			2"	2½"	3"	4"	5"	6"	8"
10	32.8	0.50	15	21	32	58	65	117	178
		0.25	10	15	23	41	46	83	126
-10	16.5	0.50	12	18	28	50	55	99	151
		0.25	8.8	13	19	35	39	70	107
-30	4.9	0.50	10	15	23	41	46	82	126
		0.25	7.3	11	16	29	62	58	89
-50	<i>6.1 in Hg</i>	0.50	8.3	12	19	33	67	67	102
		0.25	5.9	8.5	13	24	26	47	72

Capacities are based on liquid temperatures equal to evaporator temperatures. For liquid overfeed systems, nominal 2:1 to 5:1 ratio, add 20% to the evaporator load and select a valve based on the increased load.

Suction Capacities - S9A/S9W

R-134a (KW)

Evap. Temp (°C)	Evap. Pressure (barg)	ΔP (bar)	Port Size						
			50mm	65mm	75mm	100mm	125mm	150mm	200mm
-10	0.99	0.035	40	58	89	160	178	320	489
		0.017	28	41	63	113	126	226	346
-20	0.31	0.035	33	48	74	133	148	266	406
		0.017	23	34	52	94	104	188	287
-35	-0.35	0.035	27	39	60	107	119	215	328
		0.017	19	27	42	76	84	152	232
-45	-0.62	0.035	21	30	47	84	94	168	257
		0.017	15	21	33	60	66	119	182

R-134a (TONS)

Evap. Temp (°F)	Evap. Pressure (psig)	ΔP (psi)	Port Size						
			2"	2½"	3"	4"	5"	6"	8"
10	11.9	0.50	11	16	25	46	51	91	139
		0.25	8.0	12	18	32	36	64	98
-10	1.9	0.50	9.4	14	21	38	42	76	115
		0.25	6.7	9.6	15	27	30	53	82
-30	9.8 in Hg	0.50	7.6	44	17	31	34	61	93
		0.25	5.4	7.8	12	22	24	43	66
-50	18.7 in Hg	0.50	6.0	8.6	13	24	27	48	73
		0.25	4.2	6.1	9.4	17	19	34	52

R-404a (KW)

Evap. Temp (°C)	Evap. Pressure (barg)	ΔP (bar)	Port Size						
			50mm	65mm	75mm	100mm	125mm	150mm	200mm
-10	3.38	0.035	50	73	112	202	224	403	616
		0.017	36	51	79	142	158	285	435
-20	2.06	0.035	43	63	96	173	192	346	529
		0.017	31	44	68	122	136	245	374
-35	0.67	0.035	36	52	81	145	161	291	444
		0.017	26	37	57	103	114	205	314
-45	0.06	0.035	30	43	66	119	132	237	363
		0.017	21	30	47	84	93	168	256

R-404a (TONS)

Evap. Temp (°F)	Evap. Pressure (psig)	ΔP (psi)	Port Size						
			2"	2½"	3"	4"	5"	6"	8"
10	44.3	0.50	14	21	32	57	64	115	175
		0.25	10	15	23	41	45	81	124
-10	24.6	0.50	12	18	27	49	55	98	150
		0.25	8.7	13	19	35	39	70	104
-30	10.3	0.50	10	15	23	41	46	83	126
		0.25	7.3	11	16	29	32	58	89
-50	0.5	0.50	8.4	12	19	34	38	68	103
		0.25	6.0	8.6	13	24	27	48	73

Capacities are based on liquid temperatures equal to evaporator temperatures. For liquid overfeed systems, nominal 2:1 to 5:1 ratio, add 20% to the evaporator load and select a valve based on the increased load.

Suction Capacities - S9A/S9W

R-410a (KW)

Evap. Temp (°C)	Evap. Pressure (barg)	ΔP (bar)	Port Size						
			50mm	65mm	75mm	100mm	125mm	150mm	200mm
-10	4.73	0.035	67	97	150	269	299	539	823
		0.017	48	69	106	191	212	381	582
-20	2.99	0.035	58	84	129	232	257	463	708
		0.017	41	59	91	164	182	327	500
-35	1.18	0.035	49	70	108	194	216	389	594
		0.017	34	50	76	137	153	275	420
-45	0.38	0.035	40	57	88	159	177	318	486
		0.017	28	41	62	112	125	225	344

R-410a (TONS)

Evap. Temp (°F)	Evap. Pressure (psig)	ΔP (psi)	Port Size						
			2"	2½"	3"	4"	5"	6"	8"
10	62.4	0.50	19	28	43	77	85	153	234
		0.25	14	20	30	54	60	108	166
-10	36.5	0.50	16	24	37	66	73	132	201
		0.25	12	17	26	47	52	93	142
-30	17.8	0.50	14	20	31	55	61	111	169
		0.25	10	14	22	39	43	78	119
-50	5.0	0.50	11	16	25	45	50	90	138
		0.25	8.0	12	18	32	36	64	98

R-507a (KW)

Evap. Temp (°C)	Evap. Pressure (barg)	ΔP (bar)	Port Size						
			50mm	65mm	75mm	100mm	125mm	150mm	200mm
-10	3.48	0.035	51	73	113	203	226	406	621
		0.017	36	52	80	144	160	287	439
-20	2.13	0.035	44	63	97	175	195	350	535
		0.017	31	45	69	124	138	248	378
-35	0.71	0.035	37	53	82	147	164	295	450
		0.017	26	38	58	104	116	208	318
-45	0.09	0.035	30	44	67	121	134	242	369
		0.017	21	31	48	86	95	171	261

R-507a (TONS)

Evap. Temp (°F)	Evap. Pressure (psig)	ΔP (psi)	Port Size						
			2"	2½"	3"	4"	5"	6"	8"
10	45.7	0.50	14	21	32	58	64	116	177
		0.25	10	15	23	41	45	82	125
-10	25.5	0.50	12	18	28	50	55	100	152
		0.25	8.8	13	20	35	39	70	108
-30	11.0	0.50	10	15	23	42	47	84	128
		0.25	7.4	11	16	30	33	59	91
-50	3.0	0.50	8.6	12	19	34	38	69	105
		0.25	6.1	8.8	14	24	27	49	74

Capacities are based on liquid temperatures equal to evaporator temperatures. For liquid overfeed systems, nominal 2:1 to 5:1 ratio, add 20% to the evaporator load and select a valve based on the increased load.

Gas Powered

Gravity Flooded Capacities

R-717 (KW)

Port Size	Valve Type	Liquid Leg	Gas Return for Evaporator Temperature			
			-10 °C	-20 °C	-30 °C	-40 °C
32	CK-2 CK-5	14	9.1	7.3	5.6	4.2
40	CK-2 CK-5	21	14	11	8.4	6.3
50	CK-2 CK-5 S9A	39	34	27	21	16
65	CK-2 CK-5 S9A	63	56	42	34	26
75	CK-2 CK-5 S9A	100	94	73	56	42
100	CK-2 CK-5 S9A	210	200	160	120	94
125	CK-2 CK-5 S9W	350	360	290	220	160
150	CK-2 CK-5 S9W	560	590	460	360	270
200	S9W	880	880	730	560	420

R-717 (TONS)

Port Size	Valve Type	Liquid Leg	Gas Return for Evaporator Temperature			
			20 °F	0 °F	-20 °F	-40 °F
1¼	CK-2 CK-5	4	2.6	2.1	1.6	1.2
1½	CK-2 CK-5	6	4.0	3.2	2.4	1.8
2	CK-2 CK-5 S9A	11	9.7	7.7	5.9	4.5
2½	CK-2 CK-5 S9A	18	16	12	9.6	7.3
3	CK-2 CK-5 S9A	30	27	21	16	12
4	CK-2 CK-5 S9A	60	57	45	35	27
5	CK-2 CK-5 S9W	100	100	82	63	48
6	CK-2 CK-5 S9W	160	170	130	100	78
8	S9W	250	270	210	160	120

Capacities are nominal and are based on accepted industry practice concerning surge drum height and evaporator geometry.

R-22 (KW)

Port Size	Valve Type	Liquid Leg	Gas Return for Evaporator Temperature			
			-10 °C	-20 °C	-30 °C	-40 °C
32	CK-2 CK-5	3.2	3.5	3.0	2.5	2.1
40	CK-2 CK-5	4.6	6.2	5.3	4.5	3.7
50	CK-2 CK-5 S9A	8.9	13	12	9.8	8.0
65	CK-2 CK-5 S9A	14	20	17	15	12
75	CK-2 CK-5 S9A	24	36	31	26	21
100	CK-2 CK-5 S9A	48	77	67	56	46
125	CK-2 CK-5 S9W	76	130	120	91	75
150	CK-2 CK-5 S9W	130	230	200	160	140
200	S9W	200	350	330	250	210

R-22 (TONS)

Port Size	Valve Type	Liquid Leg	Gas Return for Evaporator Temperature			
			20 °F	0 °F	-20 °F	-40 °F
1¼	CK-2 CK-5	0.93	1.1	0.96	0.79	1.2
1½	CK-2 CK-5	1.3	2.0	1.7	1.4	2.2
2	CK-2 CK-5 S9A	2.5	3.8	3.2	2.7	3.4
2½	CK-2 CK-5 S9A	4.3	6.1	5.2	4.3	5.9
3	CK-2 CK-5 S9A	7.1	10	9.0	7.5	12
4	CK-2 CK-5 S9A	14	20	19	16	20
5	CK-2 CK-5 S9W	25 25 22	37	31	25	35
6	CK-2 CK-5 S9W	39	65	53	43	57
8	S9W	60	100	88	73	

Capacities are nominal and are based on accepted industry practice concerning surge drum height and evaporator geometry.

Dual Position Control Valves

Designed to eliminate the damaging effects of hydraulic shock caused by liquid deceleration, vapor propelled liquid slugs, and condensation induced hydraulic shock, the S4AD, CK-2D, and CK-6D combine the features of hot gas/soft gas valve configurations and suction stop with equalization valve configurations. The S4AD can additionally be used for high pressure liquid make up applications to prevent liquid hammer, replacing parallel liquid line solenoid valves.

The CK-2D and CK-6D are low pressure drop, gas powered suction stop valves, for low temperature ammonia, approved CFC, HCFC, or HFC refrigerants and corresponding approved refrigerant oils or fluids. The CK-2D is a normally open valve, which uses discharge gas to power the valve closed. The CK-6D incorporates a fail safe feature, which holds the valve in the equalizing position until a safe coil pressure is reached, should a power failure occur during the defrost cycle.

The valve position is controlled via the sequencing of two integral pilot solenoids and can be held in a closed, partially

open (approximately 10% of full flow) or fully open position. By sequencing the solenoids based on time, users have the flexibility to set each stage to meet their specific needs.

Use solenoid capacity tables on pages **35 - 46** for the S4AD valve and gas powered capacity tables on pages **49 - 54** for the CK-2D and CK-6D valves.

Specifications

Temperature Range -50°C to 105°C (-60°F to 220°F)
 Maximum Rated Pressure (MRP) 27.6 bar (400 psig)

DIN Specifications

Temperature Range -50°C to 105°C (-60°F to 220°F)
 Maximum Rated Pressure (MRP) 28 bar (406 psig)

Gas Powered

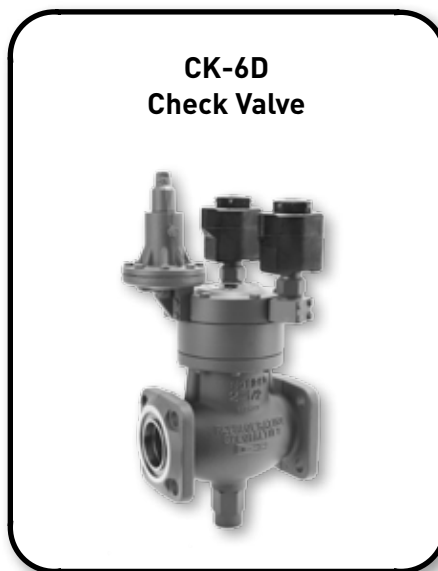

Specifications

Port Size		Type	Seat Material	Standard Body Material	*DIN Body Material	Minimum Pressure Drop to Open		Minimum Pressure Drop to Close		Operation	Coil	Bulletin
mm	inch					bar	psi	bar	psi			
20 - 32	¾ - 1¼	S4AD	PTFE	Gray Iron	GGG-40.3	0.28	4	-	-	Normally Closed	S6A	30-95
40 - 100	1½ - 4	S4AD	Metal	Gray Iron	GGG-40.3	0.14	2	-	-	Normally Closed	S6A	30-95
40 - 100	1½ - 4	CK-2D	Metal	Gray Iron	GGG-40.3	0	0	0.35	5	Normally Open	S6A or *S6B	50-24
40 - 100	1½ - 4	CK-6D	Metal	Gray Iron	GGG-40.3	0	0	0.35	5	Normally Open	S6A or *S6B	50-25

*Complies with Pressure Equipment Directive 97/23/EC

Bold* Valves containing S6B coils can be installed in a vertical or horizontal position.

Recommendations assume no highly viscous oil, dirt, moisture or foreign substance in refrigerant; also no abnormal shock impact below -30°C (-25°F). Use CK-2 only above -30°C (-25°F) if not powered by near oil free hot gas such as in rotary screw compressor systems.

Dual Position Control Valves

General Information

Port Size		Type	Description	Flow Coefficient		Connections Available		
mm	inch			Kv	Cv	FPT, SW, WN	ODS	WN (DN)
20	¾	S4AD	Spring Closing	6.9	8.1	¾", 1", 1¼"	7⁄8", 1½", 1¾"	20, 25, 32
25	1	S4AD	Spring Closing	8.4	9.9	¾", 1", 1¼"	7⁄8", 1½", 1¾"	20, 25, 32
32	1¼	S4AD	Spring Closing	17	20	1¼", 1½"	1½"	32
		CK-2D	Normally Open	16	19			
		CK-6D	Normally Open	16	19			
40	1½	S4AD	Spring Closing	27	32	1½", 2"	2½", 2⅝"	38, 50
		CK-2D	Normally Open	32	37			
		CK-6D	Normally Open	32	37			
50	2	S4AD	Spring Closing	46	53	1½", 2"	2½", 2⅝"	38, 50
		CK-2D	Normally Open	44	51			
		CK-6D	Normally Open	44	51			
65	2½	S4AD	Spring Closing	64	75	2½", 3" (No FPT)	2⅝", 3⅞"	65
		CK-2D	Normally Open	70	82			
		CK-6D	Normally Open	70	82			
75	3	S4AD	Spring Closing	86	100	3" (No FPT)	3⅞", 3⅝"	75
		CK-2D	Normally Open	103	120			
		CK-6D	Normally Open	103	120			
100	4	S4AD	Spring Closing	130	150	4" (No FPT)	4⅞"	100
		CK-2D	Normally Open	171	200			
		CK-6D	Normally Open	171	200			

FPT flanges are only available 20 - 50mm (¾" - 2")

Coils

S6A Modular Solenoid Pilot

Adds electric shut-off (S) or electric wide opening (B) and is used with Modular Pressure Pilot A2D/A2D2 for dual (D) variations. Class "F" U.L. approved system with housing meeting 3R and 4 requirements.

Furnished with bolts and O-rings. Mounts to Moduadapter®. Same for all regulator sizes.

Coil (Volts/Hz)	Power Lead	Neutral Lead	Inrush Current (Amps)	Running Current (Amps)	Fuse Size (Amps)	Temp °C (°F)
24/50	Brown	White	6.82	2.99	4	250 (482)
24/60	Brown	White	6.70	2.73	4	250 (482)
115/50	Purple	White	1.22	0.21	1	90 (194)
120/60	Blue	White	1.18	0.46	1	90 (194)
208/60	Red	White	0.63	0.24	1	90 (194)
230/50	Yellow	White	0.65	0.26	1	90 (194)
240/50	Black	White	0.59	0.24	1	90 (194)
240/60	Orange	White	0.60	0.23	1	98 (208)
12 DC	Brown	White	-	-	-	-
24 DC	Brown	White	6.70	6.70	-	204 (400)

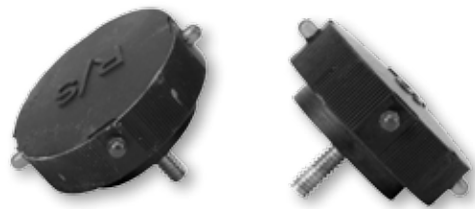

Notes: LED knobs can only be used on AC coils.

S6B Compact Modular Solenoid Pilot

The S6B, Class "H" coil, is an optional pilot solenoid which can be mounted on the CK-5 gas powered suction stop valve, CK-2D and CK-6D dual position gas powered suction stop valves. Due to the "spring assisted" construction of the valve's plunger assembly allow the valves to be mounted on its side as opposed to the S6A, which must be mounted in a vertical position for the pilot solenoid to positively close when de-energized.

The supply circuits must be properly sized to give adequate voltage at the coil leads even when other electrical equipment is operating. The coil is designed to operate at 15% under voltage. Operating with line voltage below the limit will result in lowering the valve opening pressure differential.

S6B Voltage Availability

110-120V 50-60Hz, 220-240V 50-60Hz, 208V 60Hz, 240V 50Hz, and 24V 60Hz



Coils

Coils

SV2 Compact Modular Solenoid Pilot

These water resistant Class “H” solenoid coil is designed for long life and powerful opening force. The solenoid coil must be connected to electrical lines with Volts and Hertz the same as specified on the coil assembly. The supply circuits must be properly sized to give adequate voltage at the coil leads even when other electrical equipment is operating. The coil is designed to operate at 15% under voltage. Operating with line voltage below the limit will result in lowering the valve opening pressure differential.



Coil Type	Watts	Inrush Current (Amps)	Running Current (Amps)	Temp °C (°F)
Standard AC Coil - Class 'H'	10.5	37	23	180 (365)

SV2 Coil Voltage Availability

110-120V 50-60Hz, 220-240V 50-60Hz, 208V 60Hz, 240V 50Hz, and 24V 60Hz

Voltages

Available Voltages for Coils and Remote Pilot Lights	Module	Class	120/60	120/6/60	208/60	208/6/60	240/60	240/6/60	115/50	230/50	240/50	24/60	24/50	48/50	24 VDC	48 VDC
Encapsulated w/Leads	S6A	F	•	•	•	•	•	•		•		•	•	•	•	
Encapsulated w/Leads & Integral Pilot Light	S6A	F	•		•		•									
Encapsulated w/DIN Connector	S6A	F	•				•		•	•	•				•	•
Encapsulated w/DIN & Integral Pilot Light	S6A	F	•				•		•	•	•					
Compact Operator w/Leads	S6B	H	•		•		•		•	•	•					
Compact Operator w/DIN Connector	S6B	H	•		•		•		•	•	•					
Explosion Proof	X	—	•		•		•		•	•		•			•	
Compact Operator w/Leads	SV2	H	■		•		■		•	•	•	•	•			
Compact Operator w/DIN Connector	SV2	H	■		•		■		•	•	•	•	•			

Coils are available from stock with most standard voltages; see table above.
 Non-standard voltages; shown in the shaded area of table.
 Consult factory for other voltages.

- These voltages for the Class “H” coils are 120/60 - 110/50, 240/60 - 220/50, 480/60 - 440/50.

Notes: Remote pilot lights cannot be used with explosion proof or unleaded coils.
 Consult factory for information on explosion proof coils.

Check Valves (CK-1)

These piston type, gravity closing, heavy duty check valves prevent backward flow of fluid in refrigerant suction, hot gas or liquid lines. They are recommended for compressor discharge lines, also for liquid lines and suction lines.

The check valve opens by the pressure difference between valve inlet and outlet. The pressure difference must be a minimum of 0.03 bar (0.5 psi).

Specifications

Port Sizes	20mm to 150mm (¾" to 6")
Temperature Range	-30°C to 105°C (-25°F to 220°F)
Maximum Rated Pressure (MRP)	27.6 barg (400 psig)
Minimum Pressure Drop to Open	0.03 bar (0.5 psi)
Body	Gray Iron (ASTM A126 Class B)
Seat Material: 20mm - 32mm (¾" - 1¼")	PTFE
40mm - 150mm (1½" - 6")	Metal

DIN Specifications

Port Sizes	32mm to 100mm (1¼" to 4")
Temperature Range	-30°C to 105°C (-25°F to 220°F)
Maximum Rate Pressure (MRP)	28 barg (406 psig)
Minimum Pressure Drop to Open	0.03 bar (0.5 psi)
Body	Ductile Iron (GGG40.3)
Seat: 20mm - 32mm (¾" - 1¼")	PTFE
40mm - 150mm (1½" - 6")	Metal



General Information

Port Size		Operation	Flow Coefficient		Connections Available			
mm	inch		Kv	Cv	FPT	SW, WN	ODS	WN (DN)
20	¾	Gravity Closing	8.1	9.5	¾", 1", 1¼"	¾", 1", 1¼"	7/8", 1½", 1¾"	20, 25, 32
25	1	Gravity Closing	8.6	10	¾", 1", 1¼"	¾", 1", 1¼"	7/8", 1½", 1¾"	20, 25, 32
32	1¼	Gravity Closing	16	19	1¼", 1½"	1¼", 1½"	1½"	32
40	1½	Gravity Closing	32	37	1½", 2"	1½", 2"	2½", 2¾"	38, 50
50	2	Gravity Closing	44	51	1½", 2"	1½", 2"	2½", 2¾"	38, 50
65	2½	Gravity Closing	70	82	—	2½", 3"	2¾", 3½"	65, 75
75	3	Gravity Closing	103	120	—	3"	3½", 3¾"	75
100	4	Gravity Closing	171	200	—	4"	4½"	100
125	5	Gravity Closing	244	285	—	5" WN only	—	—
150	6	Gravity Closing	342	400	—	6" WN only	—	—

For more information see bulletin 50-10.

Application Guide

Port Size		Operation	Mounting
mm	inch		
20 - 150	¾ - 6	1. Slow speed compressor discharge lines 2. Liquid lines 3. Suction lines down to -30°C (-25°F) 4. Side port applications on screw compressors	Horizontal lines with opening stem in the vertical position

Note: Close coupling, valves sizes through 4", using male adapter ring to outlet of R/S control valves.

CK-1 Capacity Tables

R-717 (KW)

Port Size (mm)	Liquid Line ①		Hot Gas Discharge ②		Liquid Line ③ (m ³ /hr)
	Pressure Drop (bar)		Pressure Drop (bar)		
	0.034	0.21	0.034	0.21	
20	531	1062	44	109	1.5
25	559	1118	47	114	1.6
32	1062	2124	89	217	3.0
40	2068	4135	173	423	5.9
50	2850	5700	238	583	8.1
65	4582	9165	382	937	13
75	6706	13412	560	1371	19
100	11177	22353	933	2285	32
125	—	—	1329	3256	—
150	—	—	1866	4570	—

R-717 (TONS)

Port Size (inch)	Liquid Line ①		Hot Gas Discharge ②		Liquid Line ③ (gpm)
	Pressure Drop (psi)		Pressure Drop (psi)		
	0.5	3.0	0.5	3.0	
¾	151	302	13	31	6.6
1	159	318	13	32	7.0
1¼	302	604	25	62	13
1½	588	1176	49	120	26
2	810	1621	68	166	36
2½	1303	2606	109	266	57
3	1907	3814	159	390	84
4	3178	6356	265	650	139
5	—	—	378	926	—
6	—	—	531	1300	—

R-22 (KW)

Port Size (mm)	Liquid Line ①		Hot Gas Discharge ②		Liquid Line ③ (m ³ /hr)
	Pressure Drop (bar)		Pressure Drop (bar)		
	0.034	0.21	0.034	0.21	
20	102	249	18	44	2.0
25	107	262	19	46	2.1
32	204	498	36	88	4.0
40	396	971	70	171	7.8
50	546	1338	96	236	11
65	878	2151	155	379	17
75	1285	3148	226	554	25
100	2142	5247	377	924	42
125	—	—	537	1316	—
150	—	—	754	1847	—

R-22 (TONS)

Port Size (inch)	Liquid Line ①		Hot Gas Discharge ②		Liquid Line ③ (gpm)
	Pressure Drop (psi)		Pressure Drop (psi)		
	0.5	3.0	0.5	3.0	
¾	29	71	5.1	12	8.8
1	30	75	5.4	13	9.2
1¼	58	142	10.2	25	18
1½	113	276	20	49	34
2	155	380	27	67	47
2½	250	612	44	108	76
3	365	895	64	158	111
4	609	1492	107	263	185
5	—	—	153	374	—
6	—	—	214	525	—

① Liquid Line Capacities

R717 is based on -7°C (20°F) liquid and -18°C (0°F) evaporator temperatures. To correct for 30°C (86°F) liquid, multiply capacities by 0.9.

R22 is based on -7°C (20°F) liquid and -7°C (20°F) evaporator temperatures. For each 5°C/10°F liquid is below -7°C (20°F), increase capacities by 3%.

② Hot Gas Discharge Capacities

R717 is based on 30°C (86°F) condensing and -20°C (0°F) evaporator temperatures. Use at other typical conditions normally requires no capacity correction.

R22 is based on 38°C (100°F) condensing and -7°C (20°F) evaporator temperatures.

③ Liquid Capacities

R717 is based on -7°C (20°F) liquid temperature and 0.051 bar (0.75 psi) pressure drop.

R22 is based on 38°C (100°F) liquid temperature and 0.051 bar (0.75 psi) pressure drop.

Correction factors for temperatures between -40°C (-40°F) and 30°C (86°F) are negligible.

Suction Line Capacities

CK-1 suction line capacities are the same as the values for the CK-2 valves at 0.034 bar (0.5 psi) pressure drop. Refer to the CK-2 tables on page 49.

CK-1 Capacity Tables

R-134a (KW)

Port Size (mm)	Liquid Line ①		Hot Gas Discharge ②		Liquid Line ③ (m ³ /hr)
	Pressure Drop (bar)		Pressure Drop (bar)		
	0.034	0.21	0.034	0.21	
20	99	242	15	37	2.0
25	104	255	16	39	2.1
32	198	485	30	74	4.0
40	386	944	59	145	7.8
50	531	1302	82	200	11
65	854	2093	131	321	17
75	1250	3063	192	470	25
100	2084	5104	320	784	42
125	—	—	456	1117	—
150	—	—	640	1567	—

R-134a (TONS)

Port Size (inch)	Liquid Line ①		Hot Gas Discharge ②		Liquid Line ③ (gpm)
	Pressure Drop (psi)		Pressure Drop (psi)		
	0.5	3.0	0.5	3.0	
3/4	28	69	4.3	11	8.8
1	30	73	4.5	11	9.3
1 1/4	56	138	8.6	21	18
1 5/8	110	269	17	41	34
2	151	370	23	57	48
2 1/2	243	595	37	91	76
3	356	871	55	134	112
4	593	1451	91	223	186
5	—	—	130	317	—
6	—	—	182	446	—

R-404a (KW)

Port Size (mm)	Liquid Line ①		Hot Gas Discharge ②		Liquid Line ③ (m ³ /hr)
	Pressure Drop (bar)		Pressure Drop (bar)		
	0.034	0.21	0.034	0.21	
20	79	193	8.2	20	1.8
25	83	203	8.6	21	1.9
32	158	386	16	40	3.7
40	307	752	32	78	7.2
50	423	1036	44	108	9.9
65	680	1666	71	173	16
75	996	2439	104	254	23
100	1659	4065	173	423	39
125	—	—	246	602	—
150	—	—	345	845	—

R-404a (TONS)

Port Size (inch)	Liquid Line ①		Hot Gas Discharge ②		Liquid Line ③ (gpm)
	Pressure Drop (psi)		Pressure Drop (psi)		
	0.5	3.0	0.5	3.0	
3/4	22	55	2.3	5.7	8.1
1	24	58	2.5	6.0	8.6
1 1/4	45	110	4.7	11	16
1 5/8	87	214	9.1	22	32
2	120	295	13	31	44
2 1/2	193	474	20	49	70
3	283	693	29	72	103
4	472	1156	49	120	171
5	—	—	70	171	—
6	—	—	98	240	—

① Liquid Line Capacities

R134a is based on -7°C (20°F) liquid and -7°C (20°F) evaporator temperatures. For each 5°C/10°F liquid is below -7°C (20°F), increase capacities by 3.5%.
R404a is based on -7°C (20°F) liquid and -7°C (20°F) evaporator temperatures. For each 5°C/10°F liquid is below -7°C (20°F), increase capacities by 4.0%.

② Hot Gas Discharge Capacities

R134a and R404a are based on 38°C (100°F) condensing and -7°C (20°F) evaporator temperatures.

③ Liquid Capacities

R134a and R404a are based on 38°C (100°F) liquid temperature and 0.051 bar (0.75 psi) pressure drop.
Correction factors for temperatures between -40°C (-48°F) and 30°C (86°F) are negligible.

Suction Line Capacities

CK-1 suction line capacities are the same as the values for the CK-2 valves at 0.034 bar (0.5 psi) pressure drop. Refer to the CK-2 tables on page 50.

CK-1 Capacity Tables

R-410a (KW)

Port Size (mm)	Liquid Line ①		Hot Gas Discharge ②		Liquid Line ③ (m³/hr)
	Pressure Drop (bar)		Pressure Drop (bar)		
	0.034	0.21	0.034	0.21	
20	106	260	22	53	1.9
25	112	274	23	55	2.0
32	212	520	43	105	3.7
40	414	1013	84	205	7.2
50	570	1397	116	283	10
65	917	2246	186	455	16
75	1342	3287	272	666	23
100	2236	5478	453	1110	39
125	—	—	646	1582	—
150	—	—	906	2220	—

R-410a (TONS)

Port Size (inch)	Liquid Line ①		Hot Gas Discharge ②		Liquid Line ③ (gpm)
	Pressure Drop (psi)		Pressure Drop (psi)		
	0.5	3.0	0.5	3.0	
¾	30	74	6	15	8.2
1	32	78	6	16	8.6
1¼	60	148	12	30	16
1½	118	288	24	58	32
2	162	397	33	80	44
2½	261	639	53	129	71
3	382	935	77	189	103
4	636	1558	129	316	172
5	—	—	184	450	—
6	—	—	258	631	—

R-507a (KW)

Port Size (mm)	Liquid Line ①		Hot Gas Discharge ②		Liquid Line ③ (m³/hr)
	Pressure Drop (bar)		Pressure Drop (bar)		
	0.034	0.21	0.034	0.21	
20	77	189	16	39	1.8
25	81	199	17	41	1.9
32	155	379	32	79	3.7
40	301	738	63	153	7.2
50	415	1017	86	211	9.9
65	667	1635	139	340	16
75	977	2392	203	497	23
100	1628	3987	338	828	39
125	—	—	482	1180	—
150	—	—	676	1656	—

R-507a (TONS)

Port Size (inch)	Liquid Line ①		Hot Gas Discharge ②		Liquid Line ③ (gpm)
	Pressure Drop (psi)		Pressure Drop (psi)		
	0.5	3.0	0.5	3.0	
¾	22	54	4.6	11	8.1
1	23	57	4.8	12	8.6
1¼	44	108	9.1	22	16
1½	86	210	18	44	32
2	118	289	25	60	44
2½	190	465	39	97	70
3	278	680	58	141	103
4	463	1134	96	235	171
5	—	—	137	336	—
6	—	—	192	471	—

① **Liquid Line Capacities**

R410a is based on -7°C (20°F) liquid and -7°C (20°F) evaporator temperatures. For each 5°C/10°F liquid is below -7°C (20°F), increase capacities by 3.5%. R507a is based on -7°C (20°F) liquid and -7°C (20°F) evaporator temperatures. For each 5°C/10°F liquid is below -7°C (20°F), increase capacities by 4.0%.

② **Hot Gas Discharge Capacities**

R410a and R507a are based on 38°C (100°F) condensing and -7°C (20°F) evaporator temperatures.

③ **Liquid Capacities**

R410a and R507a are based on 38°C (100°F) liquid temperature and 0.051 bar (0.75 psi) pressure drop. Correction factors for temperatures between -40°C (-48°F) and 30°C (86°F) are negligible.

Suction Line Capacities

CK-1 suction line capacities are the same as the values for the CK-2 valves at 0.034 bar (0.5 psi) pressure drop. Refer to the CK-2 tables on page 51.

Check Valves

Check Valves (CK-3)

The in-line CK-3 check valve prevents backward flow of high pressure refrigerant gases and liquid. The PTFE valve seat and stainless steel body allows the CK-3 to withstand corrosive environments associated in industrial refrigeration conditions.

The spring loaded check valve requires a minimum 0.34 bar (5 psi) pressure drop to overcome the spring force and lift the valve seat, allowing the check valve to be mounted in any position. The valve opens wide for flow in the arrow direction on the body of the valve. When flow reversal occurs the CK-3 valve closes quickly and reliably.

Specifications

Temperature Range	-30°C to 105°C (-25°F to 220°F)
Maximum Rated Pressure (MRP)	27.6 bar (400 psig)
Body	Stainless Steel
Seat	PTFE
Minimum Pressure Drop	0.34 barg (5.0 psig)



General Information

Port Size		Flow Coefficient		Connections Available
mm	inch	Kv	Cv	FPT
13	1/2	8.1	9.5	1/2"
20	3/4	9.0	10.5	3/4"
25	1	9.8	11.5	1"

For more information see bulletin 50-13.

Application Guide

Port Size		Operation	Mounting
mm	inch		
13 - 25	1/2 - 1	1. Hot gas lines from pan to evaporator 2. Liquid lines	Any position

Check Valves

In-Line Check Valves (CK4A)

The in-line CK4A check valves prevent backward flow of fluid in refrigerant suction, hot gas or liquid lines. The primary use for these valves is in discharge and suction lines of screw compressor systems. They are also suited for high speed piston compressor discharge and for compressor suctions

Specifications

Port Sizes	13mm to 200mm (1/2" to 8")
Temperature Range	-50°C to 105°C (-60°F to 220°F)
Maximum Rated Pressure (MRP)	34.5 barg (500 psig)
Body: 13mm (1/2")	Cast Steel
20mm - 200mm (3/4" - 8")	Cast Steel (A-352 GR, LCB)
Pressure Drop: 13mm - 100mm (1/2" - 4")	0.05 barg (0.75 psig)
125mm - 200mm (5" - 8")	0.04 barg (0.60 psig)
Operation	Spring Closing

DIN Specifications

Port Sizes	13mm to 100mm (1/2" to 4")
Temperature Range	-50°C to 105°C (-60°F to 220°F)
Maximum Rated Pressure (MRP)	34.5 barg (500 psig)
Body	Ductile Iron (GGG-40.3)
Pressure Drop: 13mm - 100mm (1/2" - 4")	0.05 barg (0.75 psig)
125mm - 200mm (5" - 8")	0.04 barg (0.60 psig)
Operation	Spring Closing



General Information

Type	Port Size		Flow Coefficient		Connections Available			
	mm	inch	Kv	Cv	FPT	SW, WN	ODS	WN (DN)
CK4A-2	13	1/2	2.9	3.4	1/2", 3/8", 3/4"	1/2", 3/8", 3/4"	1/2", 5/8", 7/8"	20, 25, 32
CK4A-3	20	3/4	6.1	7.1	3/4", 1", 1 1/4"	3/4", 1", 1 1/4"	7/8", 1 1/8", 1 3/8"	20, 25, 32
CK4A-4	25	1	11	13	3/4", 1", 1 1/4"	3/4", 1", 1 1/4"	7/8", 1 1/8", 1 3/8"	32
CK4A-6	32	1 1/4	16	19	1 1/4", 1 1/2"	1 1/4", 1 1/2"	1 5/8"	38, 50
CK4A-8	50	2	39	46	1 1/2", 2"	1 1/2", 2"	2 1/8", 2 5/8"	38, 50
CK4A-9	65	2 1/2	60	70	—	2 1/2", 3"	2 5/8", 3 1/8"	65, 75
CK4A-0	75	3	96	112	—	3"	3 1/8", 3 5/8"	75
CK4A-16	100	4	180	210	—	4"	4 1/8"	100
CK4A-20	125	5	240	280	—	5"	—	—
CK4A-24	150	6	390	455	—	6"	—	—
CK4A-32	200	8	670	783	—	8"	—	—

Close coupling, valves sizes through 100mm (4"), using male adapter ring to outlet of R/S control valves.
 For more information see bulletin 50-16 for valve types CK4A-2 to CK4A-16 and 50-20 for valve types CK4A-20 to CK4A-32.

Application Guide

Port Size		Operation	Mounting
mm	inch		
13 - 200	1/2 - 8	1. Liquid lines 2. High speed compressor discharge lines (Not recommended for slow speed compressor discharge lines) 3. Pump discharge lines 4. Suction lines down to -55°C (-60°F) 5. Hot gas lines from pan to evaporator 6. Defrost relief regulator venting to an intermediate pressure 7. Prevent receiver pressure from backing up into a cold condenser 8. Prevent liquid returning to compressor during shutdown 9. Prevent liquid from flowing down into drain pan 10. Prevent reverse flow in suction line due to unusual load conditions	Any position Note: not recommended for side port applications on screw compressors

Check Valves

CK4A Capacity Tables

R-717 (KW)

Port Size (mm)	Liquid Line ①		Hot Gas Discharge ②		Suction Line ③	Liquid Line ④ (m³/hr)
	Pressure Drop (bar)		Pressure Drop (bar)			
	0.052	0.21	0.052	0.21		
13	190	380	19	39	7.5	0.5
20	397	794	41	81	16	1.1
25	726	1453	74	149	29	2.1
32	1062	2124	109	217	42	3.0
50	2571	5141	263	526	101	7.3
65	3912	7824	400	800	154	11
75	6259	12518	640	1280	247	18
100	11735	23471	1200	2399	463	33
125	—	—	1600	3199	617	—
150	—	—	2599	5199	1002	—
200	—	—	4473	8946	1725	—

R-717 (TONS)

Port Size (inch)	Liquid Line ①		Hot Gas Discharge ②		Suction Line ③	Liquid Line ④ (gpm)
	Pressure Drop (psi)		Pressure Drop (psi)			
	0.75	3.0	0.75	3.0		
½	54	108	5.5	11	2.1	2.4
¾	113	226	12	23	4.4	4.9
1	207	413	21	42	8.1	9.1
1¼	302	604	31	62	12	13
2	731	1462	75	149	29	32
2½	1112	2225	114	227	44	49
3	1780	3559	182	364	70	78
4	3337	6674	341	682	132	146
5	—	—	455	910	175	—
6	—	—	739	1478	285	—
8	—	—	1272	2544	490	—

R-22 (KW)

Port Size (mm)	Liquid Line ①		Hot Gas Discharge ②		Suction Line ③	Liquid Line ④ (m³/hr)
	Pressure Drop (bar)		Pressure Drop (bar)			
	0.052	0.21	0.052	0.21		
13	45	89	7.9	16	3.8	0.7
20	93	186	16	33	7.9	1.5
25	171	341	30	60	14	2.7
32	249	498	44	88	21	4.0
50	603	1207	106	212	51	9.7
65	918	1837	162	323	78	15
75	1469	2938	259	517	125	24
100	2755	5510	485	970	234	44
125	—	—	647	1293	312	—
150	—	—	1051	2101	507	—
200	—	—	1808	3616	872	—

R-22 (TONS)

Port Size (inch)	Liquid Line ①		Hot Gas Discharge ②		Suction Line ③	Liquid Line ④ (gpm)
	Pressure Drop (psi)		Pressure Drop (psi)			
	0.75	3.0	0.75	3.0		
½	13	25	2.2	4.5	1.1	3.1
¾	26	53	4.7	9.3	2.2	6.6
1	48	97	8.5	17	4.1	12
1¼	71	142	12	25	6.0	18
2	172	343	30	60	15	43
2½	261	522	46	92	22	65
3	418	836	74	147	35	104
4	783	1567	138	276	67	194
5	—	—	184	368	89	—
6	—	—	299	597	144	—
8	—	—	514	1028	248	—

① Liquid Line Capacities

R717 is based on -7°C (20°F) liquid and -18°C (0°F) evaporator temperatures. To correct for 30°C (86°F) liquid, multiply capacities by 0.9.

R22 is based on -7°C (20°F) liquid and -7°C (20°F) evaporator temperatures. For each 5°C/10°F liquid is below -7°C (20°F), increase capacities by 3%.

② Hot Gas Discharge Capacities

R717 is based on 30°C (86°F) condensing and -20°C (0°F) evaporator temperatures. Use at other typical conditions normally requires no capacity correction.

R22 is based on 38°C (100°F) condensing and -7°C (20°F) evaporator temperatures.

③ Suction Line Capacities

R717 is based on 32°C (90°F) liquid and -23°C (-10°F) evaporator temperatures and 0.052 bar (0.75 psi) pressure drop.

R22 is based on 38°C (100°F) liquid and -7°C (20°F) evaporator temperatures and 0.052 bar (0.75 psi) pressure drop.

④ Liquid Capacities

R717 is based on -7°C (20°F) liquid temperature and 0.51 bar (0.75 psi) pressure drop.

R22 is based on 38°C (100°F) liquid temperature and 0.051 bar (0.75 psi) pressure drop.

Correction factors for temperatures between -40°C (-48°F) and 30°C (86°F) are negligible.

Check Valves

CK4A Capacity Tables

R-134a (KW)

Port Size (mm)	Liquid Line ①		Hot Gas Discharge ②		Suction Line ③	Liquid Line ④ (m ³ /hr)
	Pressure Drop (bar)		Pressure Drop (bar)			
	0.052	0.21	0.052	0.21		
13	43	87	6.7	13	2.8	0.7
20	91	181	13.9	28	5.9	1.5
25	166	332	25	51	11	2.7
32	242	485	37	74	16	4.0
50	587	1174	90	180	38	9.7
65	893	1787	137	274	58	15
75	1429	2858	219	439	92	24
100	2680	5360	411	823	173	44
125	—	—	548	1097	231	—
150	—	—	891	1783	375	—
200	—	—	1534	3068	646	—

R-134a (TONS)

Port Size (inch)	Liquid Line ①		Hot Gas Discharge ②		Suction Line ③	Liquid Line ④ (gpm)
	Pressure Drop (psi)		Pressure Drop (psi)			
	0.75	3.0	0.75	3.0		
½	12	25	1.9	3.8	0.8	3.2
¾	26	52	4.0	7.9	1.7	6.6
1	47	94	7.2	14	3.0	12
1¼	69	138	11	21	4.5	18
2	167	334	26	51	11	43
2½	254	508	39	78	16	65
3	406	813	62	125	26	104
4	762	1524	117	234	49	196
5	—	—	156	312	66	—
6	—	—	253	507	107	—
8	—	—	436	872	184	—

R-404a (KW)

Port Size (mm)	Liquid Line ①		Hot Gas Discharge ②		Suction Line ③	Liquid Line ④ (m ³ /hr)
	Pressure Drop (bar)		Pressure Drop (bar)			
	0.052	0.21	0.052	0.21		
13	35	69	7.1	14	3.1	0.7
20	72	144	15	30	6.4	1.4
25	132	264	27	54	12	2.5
32	193	386	40	79	17	3.7
50	467	935	96	191	42	8.9
65	711	1423	146	291	63	14
75	1138	2276	233	466	101	22
100	2134	4268	437	874	190	41
125	—	—	583	1166	254	—
150	—	—	947	1894	412	—
200	—	—	1630	3259	709	—

R-404a (TONS)

Port Size (inch)	Liquid Line ①		Hot Gas Discharge ②		Suction Line ③	Liquid Line ④ (gpm)
	Pressure Drop (psi)		Pressure Drop (psi)			
	0.75	3.0	0.75	3.0		
½	9.8	19.6	2.0	4.0	0.9	2.9
¾	21	41	4.2	8.4	1.8	6.1
1	38	75	7.7	15	3.3	11
1¼	55	110	11	22	4.9	16
2	133	266	27	54	12	39
2½	202	405	41	83	18	60
3	324	647	66	133	29	96
4	607	1214	124	249	54	180
5	—	—	166	331	72	—
6	—	—	269	539	117	—
8	—	—	463	927	202	—

① Liquid Line Capacities

R134a is based on -7°C (20°F) liquid and -7°C (20°F) evaporator temperatures. For each 5°C/10°F liquid is below -7°C (20°F), increase capacities by 3.5%. R404a is based on -7°C (20°F) liquid and -7°C (20°F) evaporator temperatures. For each 5°C/10°F liquid is below -7°C (20°F), increase capacities by 4.0%.

② Hot Gas Discharge Capacities

R134a and R404a are based on 38°C (100°F) condensing and -7°C (20°F) evaporator temperatures.

③ Suction Line Capacities

R134a and R404a are based on 38°C (100°F) liquid and -7°C (20°F) evaporator temperatures and 0.052 bar (0.75 psi) pressure drop.

④ Liquid Capacities

R134a and R404a are based on 38°C (100°F) liquid temperature and 0.051 bar (0.75 psi) pressure drop. Correction factors for temperatures between -40°C (-48°F) and 30°C (86°F) are negligible.

CK4A Capacity Tables

R-410a (KW)

Port Size (mm)	Liquid Line ①		Hot Gas Discharge ②		Suction Line ③	Liquid Line ④ (m³/hr)
	Pressure Drop (bar)		Pressure Drop (bar)			
	0.052	0.21	0.052	0.21		
13	47	93	4.8	9.5	4.6	0.7
20	97	194	9.9	20	10	1.4
25	178	356	18	36	17	2.5
32	260	520	27	53	26	3.7
50	630	1260	64	129	62	9.0
65	959	1917	98	196	94	14
75	1534	3067	157	313	150	22
100	2876	5751	294	588	282	41
125	—	—	392	784	376	—
150	—	—	637	1273	611	—
200	—	—	1096	2191	1052	—

R-410a (TONS)

Port Size (inch)	Liquid Line ①		Hot Gas Discharge ②		Suction Line ③	Liquid Line ④ (gpm)
	Pressure Drop (psi)		Pressure Drop (psi)			
	0.75	3.0	0.75	3.0		
½	13	26	1.4	2.7	1.3	2.9
¾	28	55	2.8	5.7	2.7	6.1
1	51	101	5.2	10	5.0	11
1¼	74	148	7.6	15	7.3	16
2	179	358	18	37	18	40
2½	273	545	28	56	27	60
3	436	872	45	89	43	96
4	818	1635	84	167	80	181
5	—	—	111	223	107	—
6	—	—	181	362	174	—
8	—	—	312	623	299	—

R-507a (KW)

Port Size (mm)	Liquid Line ①		Hot Gas Discharge ②		Suction Line ③	Liquid Line ④ (m³/hr)
	Pressure Drop (bar)		Pressure Drop (bar)			
	0.052	0.21	0.052	0.21		
13	34	68	7.0	14.1	3.1	0.7
20	71	142	14.7	29	6.4	1.4
25	130	259	27	54	12	2.5
32	189	379	39	79	17	3.7
50	459	917	95	190	41	9.0
65	698	1395	145	290	63	14
75	1116	2233	232	464	101	22
100	2093	4186	435	870	189	41
125	—	—	580	1159	253	—
150	—	—	942	1884	410	—
200	—	—	1621	3242	706	—

R-507a (TONS)

Port Size (inch)	Liquid Line ①		Hot Gas Discharge ②		Suction Line ③	Liquid Line ④ (gpm)
	Pressure Drop (psi)		Pressure Drop (psi)			
	0.75	3.0	0.75	3.0		
½	9.6	19.3	2.0	4.0	0.9	2.9
¾	20	40	4.2	8.4	1.8	6.1
1	37	74	7.7	15	3.3	11
1¼	54	108	11	22	4.9	16
2	130	261	27	54	12	39
2½	198	397	41	82	18	60
3	317	635	66	132	29	96
4	595	1190	124	247	54	180
5	—	—	165	330	72	—
6	—	—	268	536	117	—
8	—	—	461	922	201	—

① Liquid Line Capacities

R410a is based on -7°C (20°F) liquid and -7°C (20°F) evaporator temperatures. For each 5°C/10°F liquid is below -7°C (20°F), increase capacities by 3.5%.
 R507a is based on -7°C (20°F) liquid and -7°C (20°F) evaporator temperatures. For each 5°C/10°F liquid is below -7°C (20°F), increase capacities by 4.0%.

② Hot Gas Discharge Capacities

R410a and R507a are based on 38°C (100°F) condensing and -7°C (20°F) evaporator temperatures.

③ Suction Line Capacities

R410a and R507a are based on 38°C (100°F) liquid and -7°C (20°F) evaporator temperatures and 0.052 bar (0.75 psi) pressure drop.

④ Liquid Capacities

R410a and R507a are based on 38°C (100°F) liquid temperature and 0.051 bar (0.75 psi) pressure drop.
 Correction factors for temperatures between -40°C (-48°F) and 30°C (86°F) are negligible.

Check Valves

Strainers

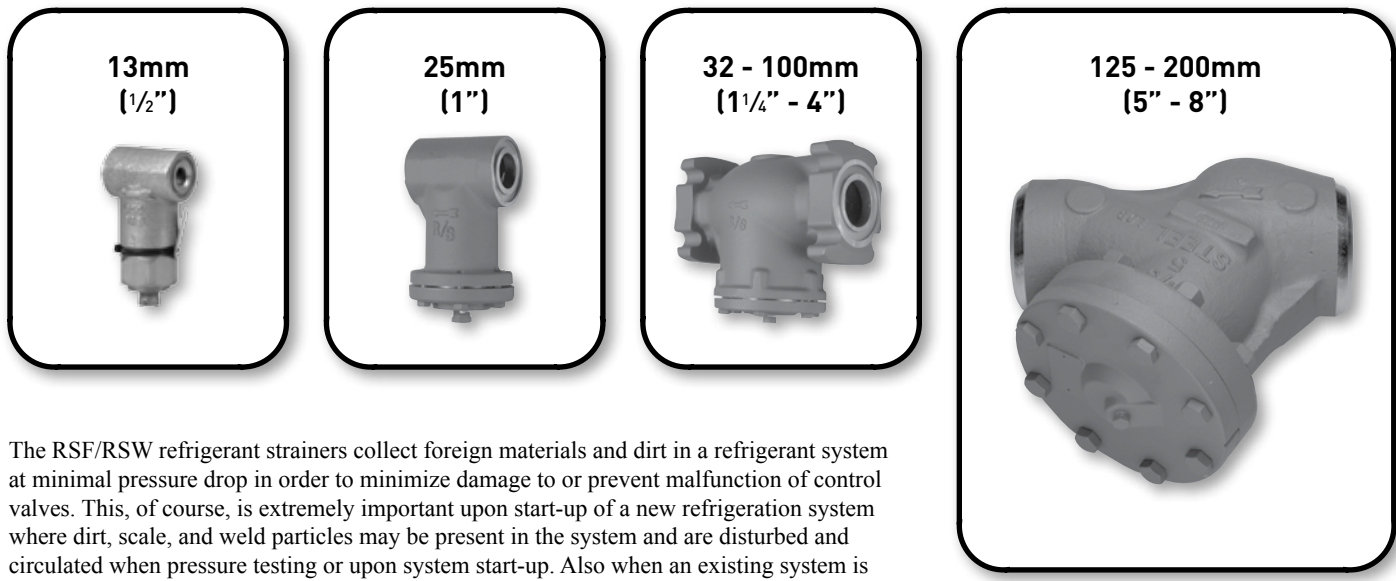

The RSF/RSW refrigerant strainers collect foreign materials and dirt in a refrigerant system at minimal pressure drop in order to minimize damage to or prevent malfunction of control valves. This, of course, is extremely important upon start-up of a new refrigeration system where dirt, scale, and weld particles may be present in the system and are disturbed and circulated when pressure testing or upon system start-up. Also when an existing system is revised, any settled dirt or foreign matter may be disturbed and circulated throughout the system.

The fine stainless screen mesh will collect particles as small as 0.009" in diameter (60 mesh @ 0.0075" wire). Generous available screen area allows maximum dirt capacity at minimum pressure drop. The strainers may be close coupled to Refrigerating Specialties valves having the same flange gasket size.

Specifications

- Port Sizes 13mm to 200mm (1/2" to 8")
- Temperature Range -50°C to 105°C (-60°F to 220°F)
- Maximum Rated Pressure (MRP) 27.6 barg (400 psig)
- Body: 13mm -100mm (1/2" - 4") Gray Iron (ASTM A126 Class B)
- 125mm - 200mm (5" - 8") Cast Steel (A-352 GR, LCB)
- Screen (60 Mesh) Stainless Steel

DIN Specifications

- Port Sizes 13mm to 125mm (1/2" to 5")
- Temperature Range -50°C to 105°C (-60°F to 220°F)
- Maximum Rated Pressure (MRP) 28 barg (406 psig)
- Body Ductile Iron (GGG40.3)
- Screen (60 Mesh) Stainless Steel

General Information

Type	Port Size		Flow Coefficient		Connections Available				Screen Area	
	mm	inch	Kv	Cv	FPT	SW, WN	ODS	WN (DN)	cm ²	in ²
RSF	5 - 13	3/16 - 1/2	2.6	3.0	3/8", 1/2", 3/4"	3/8", 1/2", 3/4"	1/2", 5/8", 7/8"	10, 15, 20	39	6
RSF	20 - 25	1/2 - 1	8.1	9.4	3/4", 1", 1 1/4"	3/4", 1", 1 1/4"	7/8", 1 1/8"	20, 25, 32	116	18
RSF	32	1 1/4	14	16	1 1/4", 1 1/2"	1 1/4", 1 1/2"	1 5/8"	32	230	36
RSF	40 - 50	1 5/8 - 2	58	68	1 1/2", 2"	1 1/2", 2"	2 1/8", 2 5/8"	40, 50	500	78
RSF	65	2 1/2	96	112	—	2 1/2"	2 5/8", 3 1/8"	65, 75	570	88
RSF	75	3	96	112	—	3"	3 1/8", 3 5/8"	75	570	88
RSF	100	4	146	170	—	4"	4 1/8"	100	794	123
RSW	125	5	185	216	—	5" (WN only)	—	—	794	123
RSW	150	6	311	362	—	6" (WN only)	—	—	1410	218
RSW	200	8	610	710	—	8" (WN only)	—	—	1750	272

For more information see bulletin 00-10 for valve type RSF and 00-12 for valve types RSW.

Strainers

Flanges

These forged flanges are used to connect two pieces of pipe or valve onto a line. In order to meet our customer needs they come in different connection types and sizes. For proper flange gasket sealing, care must be taken when threading or welding to assure flanges are parallel to each other and perpendicular to the pipe. Gaskets should be lightly oiled and all bolts must be tightened evenly.

Standard Flange Specifications

Material: 13mm - 150mm (1/2" - 6") Forged Steel and conform to ASTM A105
 Temperature Range: 13mm - 100mm (1/2" - 4") -45°C - 105°C (-50°F - 220°F)
 125mm - 200mm (5" - 8") -50°C - 105°C (-60°F - 220°F)
 Maximum Rated Pressure (MRP) 28 barg (406 psig)
 Gasket Material: 13mm - 200mm (1/2" - 8") Garlock 2930

Stainless Steel Flange Specifications

Material: 13mm (1/2") 304SS ASTM A314
 Temperature Range: 13mm (1/2") -45°C - 105°C (-50°F - 220°F)
 Maximum Rated Pressure (MRP) 28 barg (406 psig)
 Gasket Material: 13mm (1/2") Garlock 2930

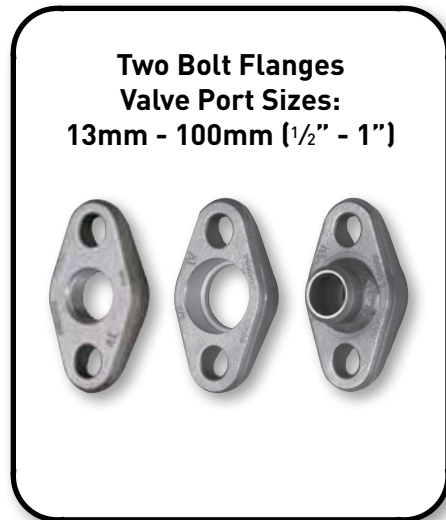

Two Bolt Flanges
Valve Port Sizes:
13mm - 100mm (1/2" - 1")

General Information

Port Size		Connections Available			
mm	inch	FPT	SW, WN	ODS	WN (DN)
5	3/16	1/4", 3/8", 1/2", 3/4"	1/4", 3/8", 1/2", 3/4"	1/2", 5/8"	13, 20
13	1/2	1/4", 3/8", 1/2", 3/4"	1/4", 3/8", 1/2", 3/4"	1/2", 5/8"	13, 20
20	3/4	3/4", 1", 1 1/4"	3/4", 1", 1 1/4"	7/8", 1 1/8", 1 3/8"	20, 25, 32
25	1	3/4", 1", 1 1/4"	3/4", 1", 1 1/4"	7/8", 1 1/8", 1 3/8"	20, 25, 32
32	1 1/4	1 1/4", 1 1/2"	1 1/4", 1 1/2"	1 5/8"	32
40	1 5/8	1 1/2", 2"	1 1/2", 2"	2 1/8", 2 5/8"	38, 50
50	2	1 1/2", 2"	1 1/2", 2"	2 1/8", 2 5/8"	38, 50
65	2 1/2	—	2 1/2", 3"	2 5/8", 3 1/8"	65, 75
75	3	—	3"	3 1/8", 3 5/8"	75
100	4	—	4"	4 1/8"	100
125	5	—	5" WN only	—	—
150	6	—	6" WN only	—	—
200	8	—	8" WN only	—	—



Four Bolt Flanges
Valve Port Sizes:
125mm - 200mm (1 1/4" - 4")

Flange and Pipe Dimensions

Nominal Inch	US Pipe Sizes		Equivalent Metric Steel Tubing		Socket Weld Flange I.D.		Weld Neck Flange O.D.		ANSI Slip-On Socket I.D.		ANIS WN Neck O.D.	
	mm	inch	NW	O.D. mm	mm	inch	mm	inch	mm	inch	mm	inch
1/4	13.72	0.540	8	13.5	14.22	0.560	13.72	0.540	—	—	—	—
3/8	17.14	0.675	10	17.2	17.65	0.695	17.14	0.675	—	—	—	—
1/2	21.34	0.840	15	21.3	21.84	0.860	21.34	0.840	—	—	—	—
3/4	26.67	1.050	20	26.9	27.81	1.090	26.67	1.050	—	—	—	—
1	33.40	1.315	25	33.7	34.67	1.365	33.40	1.315	—	—	—	—
1 1/4	42.16	1.660	32	42.4	43.31	1.705	42.16	1.660	—	—	—	—
1 5/8	48.26	1.900	40	48.3	59.02	1.930	48.25	1.900	—	—	—	—
2	60.32	2.375	50	60.3	62.1	2.445	60.30	2.375	—	—	—	—
2 1/2	73.02	2.875	65	76.1	74.8	2.945	73.03	2.875	—	—	—	—
3	88.90	3.500	75	88.9	90.81	3.575	88.90	3.500	—	—	—	—
4	114.30	4.500	100	114.3	116.2	4.575	114.30	4.500	—	—	—	—
5	141.30	5.563	125	139.7	144.0	5.670	141.30	5.563	144.14	5.675	141.3	5.563
6	168.28	6.625	150	165.1	170.9	6.730	168.28	6.625	171.07	6.735	168.28	6.625
8	—	—	—	—	—	—	—	—	221.87	8.735	219.08	8.625

Flanges Unions

The flange union kits are used to combine a male and a female flange within the same flange size code. Union kits are available for flange sizes up to 100mm (4").

The kits consists of a flange gasket and the appropriate bolts for the flange size.

**Two Bolt Flange
Threaded (FPT)**



**Four Bolt Flange
Socket Weld/Outside
Diameter Sweat (SW/ODS)**



**Four Bolt Flange
Weld Neck (WN)**



For proper flange gasket sealing, care must be taken when threading or welding to assure flanges are parallel to each other and perpendicular to the pipe. Gasket should be lightly oiled and all bolts must be tightened evenly.

Adapter Rings

Adaptor rings are furnished with two matching flange gaskets.

Male Adapter Rings (MAR)

Are used to close couple CK4A or CK-1 check valves to the outlet of Refrigerating Specialties Control Valves.

Female Adapter Rings (FAR)

Are used in unions of two male flanges.

Male Adaptor Ring



Female Adaptor Ring



Hot Gas Defrost Valve Group

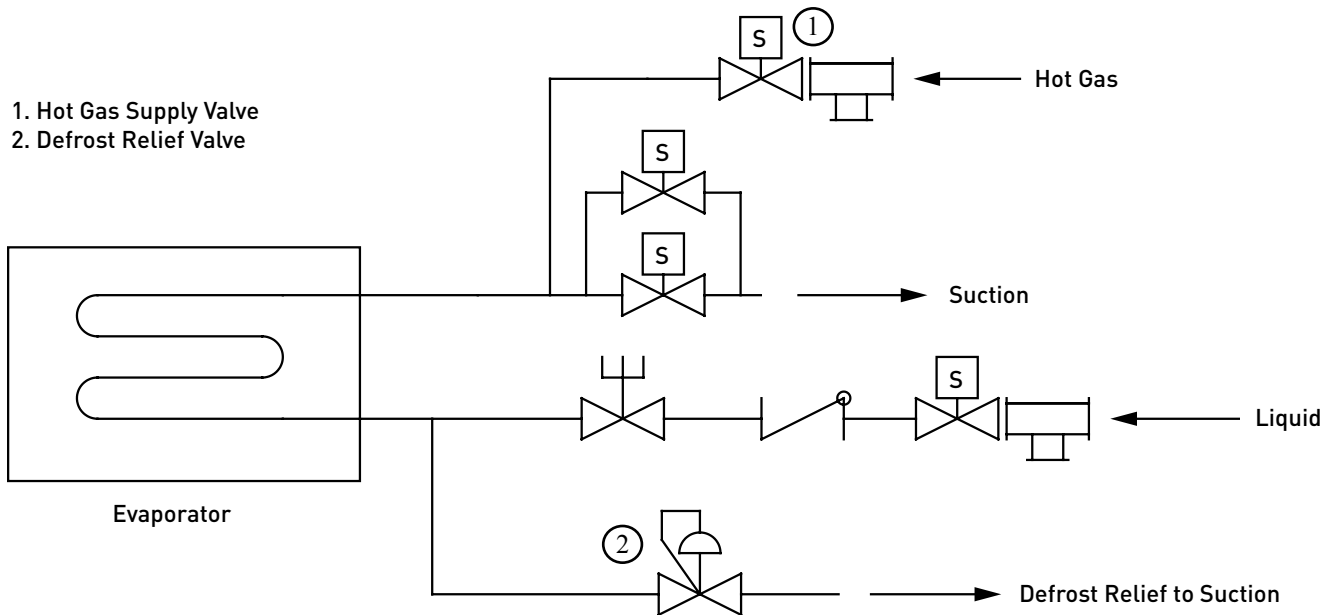

R-717 (KW)

Hot Gas Supply Valve ①		Defrost Relief Valve ②		Evaporator Temperature				
Port Size (mm)	Valve Type	Port Size (mm)	Valve Type	-10 °C	-20 °C	-30 °C	-40 °C	-50 °C
13 20	S8F, SV2 50% A4AOS	20	50% A4AOS	41	33	28	24	19
20	SV2, S4A, A4AOS	20	A4AK	78	73	63	56	47
25	SV2, S4A, A4AOS	25	A4AK	110	89	91	85	72
32	SV2, S4A, A4AOS	32	A4AK	210	190	16	140	120
40	S4A, A4AOS	40	A4AK	500	430	390	320	260
50	S4A, A4AOS	50	A4AK	640	570	460	390	330

Notes:

Nominal capacities listed are based on normal defrost times saturated hot gas inlet to valve no less than 30°C (86°F), a 5°C/10°F difference between evaporator, and an 8°C (47°F) defrost temperature. These capacities can be adjusted depending on the evaporator type and mass, the thickness of frost and other factors affecting the duration of the defrost process.

R-717 (TONS)

Hot Gas Supply Valve ①		Defrost Relief Valve ②		Evaporator Temperature				
Port Size (inch)	Valve Type	Port Size (inch)	Valve Type	20 °F	0 °F	-20 °F	-40 °F	-60 °F
½ ¾	S8F, SV2 50% A4AOS	¾	50% A4AOS	14	10	7.9	6.7	5.2
¾	SV2, S4A, A4AOS	¾	A4AK	27	22	18	16	13
1	SV2, S4A, A4AOS	1	A4AK	38	27	26	24	20
1¼	SV2, S4A, A4AOS	1¼	A4AK	72	56	45	40	34
1½	S4A, A4AOS	1½	A4AK	170	130	110	90	72
2	S4A, A4AOS	2	A4AK	220	170	130	110	91

Equalizing the coil pressure after a defrost is critical to ensure that large suction valves do not open immediately and “shock” the system after the defrost has been terminated. This is especially true on large, low temperature coils, where the difference between the defrost pressure and the house suction is the greatest, and where the internal volume of the coil is largest. The addition of a vent solenoid (usually piped in parallel to the automatic suction valve), which opens for a pre-determined period after defrost (when the hot gas solenoid de-energizes, and the suction stop valve or suction solenoid remains closed), slowly bleeds down the coil pressure. This effectively allows the defrost to terminate in a “soft” and safe manner.

Hot Gas Defrost Valve Group

- 1. Hot Gas Supply Valve
- 2. Defrost Relief Valve

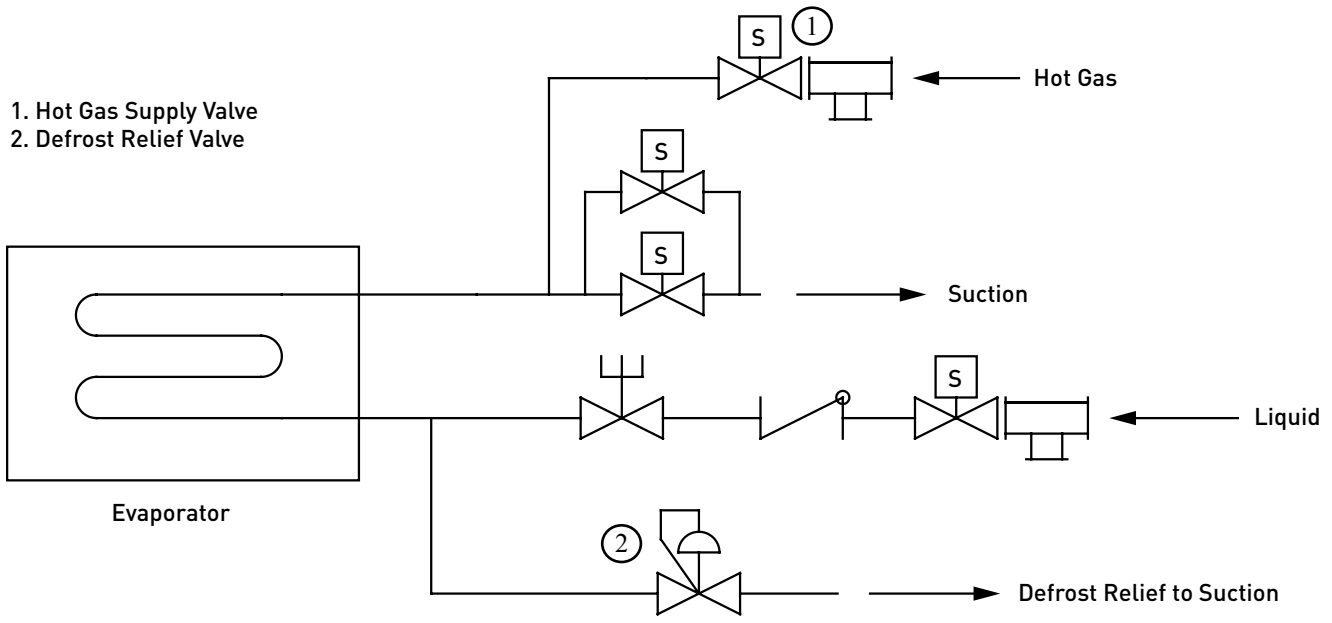

R-22 (KW)

Hot Gas Supply Valve ①		Defrost Relief Valve ②		Evaporator Temperature				
Port Size (mm)	Valve Type	Port Size (mm)	Valve Type	-10 °C	-20 °C	-30 °C	-40 °C	-50 °C
13 20	S8F, SV2 50% A4AOS	20	50% A4AOS	16	13	11	9.5	8.3
20	SV2, S4A, A4AOS	20	A4AK	32	29	25	22	19
25	SV2, S4A, A4AOS	25	A4AK	41	36	35	33	27
32	SV2, S4A, A4AOS	32	A4AK	81	73	60	56	47
40	S4A, A4AOS	40	A4AK	200	160	140	120	97
50	S4A, A4AOS	50	A4AK	250	210	180	150	120

Notes:
 Nominal capacities listed are based on normal defrost times saturated hot gas inlet to valve no less than 30°C (86°F), a 5°C/10°F difference between evaporator, and an 8°C (47°F) defrost temperature. These capacities can be adjusted depending on the evaporator type and mass, the thickness of frost and other factors affecting the duration of the defrost process.

R-22 (TONS)

Hot Gas Supply Valve ①		Defrost Relief Valve ②		Evaporator Temperature				
Port Size (inch)	Valve Type	Port Size (inch)	Valve Type	20 °F	0 °F	-20 °F	-40 °F	-60 °F
1/2 3/4	S8F, SV2 50% A4AOS	3/4	50% A4AOS	5.5	4.1	3.2	2.7	2.3
3/4	SV2, S4A, A4AOS	3/4	A4AK	11	8.7	7.1	6.3	5.4
1	SV2, S4A, A4AOS	1	A4AK	14	11	10	9.3	7.6
1 1/4	SV2, S4A, A4AOS	1 1/4	A4AK	28	22	17	16	13
1 5/8	S4A, A4AOS	1 5/8	A4AK	66	47	40	33	27
2	S4A, A4AOS	2	A4AK	84	64	50	42	34

Equalizing the coil pressure after a defrost is critical to ensure that large suction valves do not open immediately and “shock” the system after the defrost has been terminated. This is especially true on large, low temperature coils, where the difference between the defrost pressure and the house suction is the greatest, and where the internal volume of the coil is largest. The addition of a vent solenoid (usually piped in parallel to the automatic suction valve), which opens for a pre-determined period after defrost (when the hot gas solenoid de-energizes, and the suction stop valve or suction solenoid remains closed), slowly bleeds down the coil pressure. This effectively allows the defrost to terminate in a “soft” and safe manner.

Hot Gas Defrost

Defrost Controller

The Refrigerating Specialties defrost controller is a powerful, yet user friendly, device for controlling the sequence of events that occur during system defrost cycles. The controller may be applied to both industrial and commercial refrigeration systems, and is suitable for use on hot gas, electric, or water defrost applications.

Features

- Digital display
- Wide range of programmable features
- Easily upgradable to new versions of software
- Three selectable defrost initiation and termination modes
- Real time 24 hour digital clock
- 30 day time/date/day retention after power failure
- Weekend/holiday energy-saving schedules
- Settings stored indefinitely in nonvolatile memory
- RS485 communication port
- Operating temperature range 5°F to 120°F (-20°C to 50°C)
- UL/CSA/CE Approval

Basic Operating Modes

The Refrigerating Specialties defrost controller operates in any of the three basic modes below.

Normal Operation: Defrost cycles occur according to any of the initiation and termination modes.

Initiation modes: 24 hour / constant interval, constant interval, exact time, liquid feed time, remote, 24 hour / constant / remote, constant remote, or exact remote.

Termination modes: Time, time / temperature, or time remote

Weekend Operation: Allows the user to specify a special schedule to occur once each week for 1-3 days. At the end of the weekend, the normal schedule resumes. Weekend operation only works in conjunction with 24 hour / constant interval initiation.

Holiday Operation: Allows the user to specify a holiday schedule that occurs one-time only for a period of one to six days. At the end of the holiday schedule, either the normal or weekend Schedule will resume, depending on the day of the week. Holiday operation observes the defrost frequency programmed for weekend operation.

Within each of these operating modes, the controller will initiate or terminate defrost cycles based on a variety of criteria.

Defrost Cycle

The Refrigerating Specialties defrost controller will go through the following sequence when initiating a defrost cycle.

Pump Out Cycle: This prepares the evaporator for defrost by allowing the liquid refrigerant in the evaporator to be pumped or drained out through the suction line. The length of this pump out cycle is user defined, and can vary from 1 to 30 minutes.

Soft Gas Cycle (optional): The soft gas cycle reduces the likelihood of damaging pressure shocks on the evaporator coil. The length of this soft gas cycle is user defined, and can vary from 0 to 15 minutes.

Hot Gas Cycle: The length of the hot gas cycle is user defined, and can vary from 1 to 45 minutes. This cycle may also be terminated before the time expires by an analog temperature measurement that has reached its pre-set limit, or a closed remote contact.



Equalization Cycle: The equalization phase can reduce or eliminate system disruptions and sudden compressor loading caused by warm refrigerant being quickly released into the system, as well as a reduction of vapor propelled liquid. The length of this equalization cycle is user defined, and can vary from 1 to 60 minutes.

Fan Delay Cycle: This allows any remaining droplets of water on the evaporator coil to freeze, so they are not blown into the refrigerated space upon fan start up. The length of the fan delay is user defined, and can vary from 1 to 5 minutes.

Safety Relief Valves - H Series

The H series high capacity safety relief valves are designed and constructed to meet the requirements of ASME Boiler and Pressure Vessel Code and ANSI/ASHRAE 15-2007 Code requirements and bear the ASME Code Symbol (UV) indicating compliance with these codes. Employing proven principles of design, these safety relief valves are highly reliable and dependable. Precision machined moving parts of stainless steel, a PTFE disc and a cadmium-plated spring prevent sticking due to corrosion or cold welding, to assure valve opening at the set pressure long after installation. They are not suitable for corrosive ambient atmospheres such as chlorine, etc. The two-bolt flanged bottom inlet affords simple removal and replacement.

Two relief valves can be mounted on a Type M dual stop valve manifold. This arrangement permits either valve to be shut off individually and removed for repairs or inspection. Thus, one valve is always in service as required by most codes.

The high capacity of the H series valve permits the use of a small size valve which results in space saving. The valves are very sturdy and compact, requiring small headroom. The dual valve manifold assembly is especially compact and easily assembled.

Specifications

Temperature Range -45°C to 150°C (-50°F to 300°F)
 Pressure Relief Settings 3.4 to 20.7 barg (50 to 300 psig)
 Maximum Rated Pressure (MRP) 27.6 barg (400 psig)
 Body Cast Iron
 Internal Parts Stainless Steel
 Seat PTFE
 Capacity Rating Vapor Only

Application

Used with ammonia and halocarbon refrigerants in noncorrosive environments. Relief valves protect each refrigeration system pressure vessel that can be isolated by valves. Municipal codes may govern selection and installation. They may be patterned after the ASME boiler and pressure vessel code and the ANSI/ASHRAE 15-2007 safety code for mechanical refrigeration. ANSI/ASHRAE 15-2007 is highly recommended if there is no compulsory code.

The H series safety relief valve is intended to prevent the pressure of the vessel from rising more than 10% above:

- (1) the design working pressure (DWP) of the vessel or
- (2) the pressure setting of the relief device.

Whenever conditions permit, it is advisable to have the relief valve pressure setting at least 25% higher than the normal operating pressure for the system.

The relief valve pressure setting must not exceed the design working pressure of the vessel.

Selection Data

On positive displacement compressor systems, pressure limiting devices – such as high pressure cutouts – must stop the action of the pressure imposing element at no higher than 90% of the pressure setting of the pressure relief device.

On non-positive displacement compressors, pressure limiting devices – such as high pressure cutout – may be set at the design working pressure (DWP) of the high side, provided:



1. The low side is protected by a properly sized pressure at the low side DWP and
2. There are not stop valves in the system that isolate the high side from the low side.

Discharge piping from relief devices must not exceed lengths specified in ANSI/ASHRAE 15-2007 with discharge to atmosphere. Per ANSI/ASHRAE 15-2007, the formula for determining the minimum required discharge capacity of a relief device for each pressure vessel where the vessel is valved off from the refrigerating systems is:

$$C = fDL, \text{ where:}$$

C = capacity, lb/min air
 f = a factor from the table below
 D = outside diameter of the vessel in feet
 L = length of vessel in feet

Value of Factor (f)

Refrigerant	Factor (f) English (Metric)
R-717	0.5 (0.041)
R-22	1.6 (0.131)
R-134a	1.6 (0.131)
R-404a	2.5 (0.203)
R-410a	2.5 (0.203)
R-407c	1.6 (0.131)
R-502	2.5 (0.203)
R-507a	2.5 (0.203)

SRV's

Safety Relief Valves - H Series

General Information

Single H Series Safety Relief Valve							Manifold	
Valve Type	Connections		Orifice Dia. (inch)	Pressure Setting (psig)	Capacity		Connections	
	Companion Mounting Flange (inch)	Relief Valve Outlet (inch)			Lbs. Per Min Air	SCFM Air	Manifold Inlet Bottom	Relief Valve Outlet
H2	Provides 3/4" FPT	1" FPT	0.625"	50	23	302	M2 Manifold Provides 3/4" FPT	1" FPT
				75	32	422		
				100	41	541		
				125	50	661		
				150	60	780		
				175	69	899		
				200	78	1019		
				225	87	1138		
				250	96	1257		
				275	105	1377		
				300	114	1496		
H3	Provides 1" FPT	1 1/4" FPT	0.825"	50	38	498	M3 Manifold Provides 1" FPT	1 1/4" FPT
				75	53	694		
				100	68	890		
				125	83	1087		
				150	98	1283		
				175	113	1479		
				200	128	1676		
				225	143	1872		
				250	158	2068		
				275	173	2265		
				300	188	2461		
H4	Provides 1 1/4" FPT	1 1/2" FPT	1.031"	50	57	744	M4 Manifold Provides 1 1/2" FPT	1 1/2" FPT
				75	79	1037		
				100	101	1330		
				125	124	1624		
				150	146	1917		
				175	169	2211		
				200	191	2504		
				225	213	2798		
				250	236	3091		
				275	258	3385		
				300	281	3678		
H5	Provides 1 1/4" FPT	2" FPT	1.375"	50	95	1242	M4 Manifold Provides 1 1/2" FPT	2" FPT
				75	132	1732		
				100	170	2222		
				125	207	2712		
				150	244	3202		
				175	282	3692		
				200	319	4182		
				225	357	4672		
				250	394	5162		
				275	431	5653		
				300	469	6143		

SRVs

Safety Relief Valves - SR Series

Low capacity SR safety relief valves are designed and constructed to meet the requirements of Section VIII ASME Boiler and Pressure Vessel Code and ANSI/ASHRAE 15-2007 safety code for mechanical refrigeration. The low capacity SR safety relief valve meets the requirements for new installation and municipal ordinances. Precision machined moving parts of stainless steel and a PTFE disc prevent sticking due to corrosion or cold welding, to assure valve opening at the set pressure long after installation.

Specifications

Temperature Range -45°C to 150°C (-50°F to 300°F)
 Pressure Relief Settings 10.3 to 27.6 barg (150 to 400 psig)
 Maximum Rated Pressure (MRP) 27.6 barg (400 psig)
 Body Material Cast Iron
 Internal Parts Stainless Steel
 Seat PTFE
 Capacity Rating Vapor Only

Application

Used with ammonia and halocarbon refrigerants in noncorrosive environments. Relief valves protect each refrigeration system pressure vessel that can be isolated by valves.

The SR series safety relief valve is intended to prevent the pressure of the vessel from rising more than 10% above:

- (1) the design working pressure (DWP) of the vessel or
- (2) the pressure setting of the relief device.

Whenever conditions permit, it is advisable to have the relief valve pressure setting at least 25% higher than the normal operating pressure for the system.



The relief valve pressure setting must not exceed the design working pressure of the vessel.

Manifold

Type M1 manifolds designed to ASME VIII, ASHRAE and IIAR standards are available for use with SR valves.

Selection Data

See page 75 for the formula to determining the minimum required discharge capacity of a relief device for each pressure vessel.

General Information

Single SR Series Safety Relief Valve					Manifold			
Valve Type	Connections		Orifice Dia. (inch)	Pressure Setting (psig)	Capacity		Connections	
	Relief Valve Inlet (inch)	Relief Valve Outlet (inch)			Lbs. Per Min Air	SCFM Air	Manifold Inlet Bottom	Manifold Outlets
SR1	1/2" FPT	3/4" FPT	0.500"	150	10	130	M1 Manifold Provides 1/2" FPT	1/2" FPT
				200	13	170		
				250	16	210		
				300	19	250		
				350	22	290		
400	25	329						
SR2	1/2" FPT	1" FPT	0.500"	150	19	246	M1 Manifold Provides 1/2" FPT	1/2" FPT
				200	25	321		
				250	30	397		
				300	36	472		
				350	42	547		
400	48	622						
SR3	3/4" FPT	1 1/4" FPT	0.409"	150	29	377	M1 Manifold Provides 3/4" FPT	3/4" FPT
				200	38	493		
				250	46	608		
				300	55	724		
				350	64	839		
400	73	955						
SR4	3/4" FPT	1 1/2" FPT	0.478"	150	37	491	M1 Manifold Provides 3/4" FPT	3/4" FPT
				200	49	641		
				250	60	791		
				300	72	945		
				350	83	1091		
400	94	1241						

Safety Relief Valves - SRH Series

High capacity SRH safety relief valves are designed and constructed to meet the requirements of Section VIII ASME Boiler and Pressure Vessel Code and ANSI/ASHRAE 15-2007. Designed to address the large installed population of safety relief.

Specifications

Temperature Range -45°C to 150°C (-50°F to 300°F)
 Pressure Relief Settings 10.3 to 27.6 barg (150 to 400 psig)
 Maximum Rated Pressure (MRP) 27.6 barg (400 psig)
 Body Material Cast Iron
 Internal Parts Stainless Steel
 Seat PTFE
 Capacity Rating Vapor Only

Application

Used with ammonia and halocarbon refrigerants in noncorrosive environments. Relief valves protect each refrigeration system pressure vessel that can be isolated by valves.

The SR series safety relief valve is intended to prevent the pressure of the vessel from rising more than 10% above:

- (1) the design working pressure (DWP) of the vessel or
- (2) the pressure setting of the relief device.

Whenever conditions permit, it is advisable to have the relief valve pressure setting at least 25% higher than the normal operating pressure for the system.

The relief valve pressure setting must not exceed the design working pressure of the vessel.

General Information



Manifold

Type M1 manifolds designed to ASME VIII, ASHRAE and IAR standards are available for use with SRH valves.

Selection Data

See page 75 for the formula to determining the minimum required discharge capacity of a relief device for each pressure vessel.

Single SRH Series Safety Relief Valve						Manifold		
Valve Type	Connections		Orifice Dia. (inch)	Pressure Setting (psig)	Capacity		Connections	
	Relief Valve Inlet (inch)	Relief Valve Outlet (inch)			Lbs. Per Min Air	SCFM Air	Manifold Inlet Bottom	Manifold Outlets
SRH1	1/2" FPT	3/4" FPT	0.500"	150	35	463	M1 Manifold Provides 1/2" FPT	1/2" FPT
				200	46	605		
				250	57	747		
				300	68	889		
				350	79	1031		
400	89	1173						
SRH2	1/2" FPT	1" FPT	0.500"	150	35	463	M1 Manifold Provides 1/2" FPT	1/2" FPT
				200	46	605		
				250	57	747		
				300	68	889		
				350	79	1031		
400	89	1173						
SRH3	3/4" FPT	1" FPT	0.500"	150	35	463	M1 Manifold Provides 3/4" FPT	3/4" FPT
				200	46	605		
				250	57	747		
				300	68	889		
				350	79	1031		
400	89	1173						
SRH4	1" FPT	1 1/4" FPT	0.750"	150	61	798	M1 Manifold Provides 1" FPT	1" FPT
				200	79	1042		
				250	100	1287		
				300	117	1530		
				350	135	1775		
SRH5	1 1/4" FPT	1 1/2" FPT	0.750"	150	73	963	M1 Manifold Provides 1 1/4" FPT	1 1/4" FPT
				200	96	1258		
				250	118	1553		
				300	141	1848		
				350	163	2142		

Safety Relief Valves - SRLQ Series

SRLQ liquid relief valves are conventional, direct spring loaded safety relief valves designed to protect the liquid containing portions of vessels built to the ASME Boiler and Pressure Vessel Code. Employing proven principles of design, these safety relief valves are highly reliable and dependable. Precision machined moving parts of stainless steel, and a PTFE disc prevent sticking due to corrosion or cold welding and assure valve opening at the set pressure long after installation.

Specifications

Temperature Range	-45°C to 150°C (-50°F to 300°F)
Pressure Relief Settings	3.4 to 6.9 barg (50 to 100 psig)
Maximum Rated Pressure (MRP)	27.6 barg (400 psig)
Body	Cast Iron
Internal Parts	Stainless Steel
Seat	PTFE
Capacity Rating	Liquid Only

Application

The type SRLQ valves are for use with ammonia and halocarbon refrigerants in non-corrosive environments. Typical applications are liquid lines, ASME rated liquid transfer vessels and other critical system components such as heat exchangers, condensers and coolers from the effects of system blockages and continued heat input. Other suitable applications are vessels containing lubricating oil such as an oil cooler. Not suitable for water or other corrosive fluids.

Pressure setting and capacities apply only when the valve is discharging to atmospheric pressure.

The relief valve pressure setting must not exceed the design working pressure of the vessel.

Selection Data

The type SRLQ safety relief valve is intended to prevent the pressure of the vessel from rising more than 10% above the design working pressure (DWP) of the vessel or the pressure setting of the relief device, whichever is the lower pressure.

Whenever conditions permit, it is advisable to have the relief valve pressure setting (which must not exceed the design working pressure of the vessel) at least 25% higher than the normal operating pressure for the refrigerant used.

Pressure limiting devices, such as high pressure cutouts on positive displacement compressor systems, must stop the action of the pressure imposing element at no higher than 90% of the pressure setting for the pressure relief device.

For non-positive displacement compressors, the pressure limiting device, such as a high pressure cut-out, may be set at the DWP of the high side; providing, the low side is protected by a properly sized pressure relief device set to relieve pressure at low side DWP and there are no stop valves in the system that isolate the high side from the low side.

Discharge piping from relief devices must not exceed specified lengths indicated in ANSI/ASHRAE 15 with discharge to atmosphere.



The capacity ratings determined by the National Board are based on water as the test fluid. Capacity for other fluids will vary and must be corrected based on specific gravity and viscosity of the fluid at the actual or worst case service conditions.

Recommended sizing guidelines should follow local codes ANSI/ASHRAE 15, IIAR, ASME Section VIII Division 1 and API-520.

Single SRL Series Safety Relief Valve						
Valve Type	Connections		Orifice Diameter (inch)	Pressure Setting (psig)	Flow Rate (Water)	
	Relief Valve Inlet (inch)	Relief Valve Outlet (inch)			LPM	GPM
SR1LQ	1/2"	3/4"	0.229"	50	33.3	8.8
				65	37.9	10.0
				75	40.5	10.7
				85	43.2	11.4
				100	47.0	12.4
SR2LQ	3/4"	1"	0.229"	50	55.3	14.6
				65	62.8	16.6
				75	67.4	17.8
				85	71.9	19.0
				100	78.0	20.6

Hand Shut-Off Valves (Standard and Extended Bonnets)

This complete line of all steel body hand shut-off valves with bolt-on bonnets is designed and built to maintain reliability both in their seating and back seating functions. This entire line is supplied with stainless steel stems for maximum corrosion resistance and back seating capability. Maintenance costs are reduced and simplified with bolt-on bonnets.

Specifications

Material: Body Cast Steel (A-352 GR, LCB)
 Standard Bonnet: 6mm - 38mm (1/4" - 1 1/2") Forged Steel
 50mm - 200mm (2" - 8") Ductile Iron
 Extended Bonnet: 6mm - 100mm (1/4" - 4") LCB Cast Steel
 Stem 304 Stainless Steel
 Packing 25% Carbon Filled PTFE
 Temperature Range* -50°C - 204°C (-60°F - 400°F)
 * Standard bonnets are not designed to be used with insulation.
 Maximum Rated Pressure (MRP) 27.6 barg (400 psig)

Availability

Connection Type	Body Type	Port Size	
		mm	Inch
Threaded (FPT)	Globe "T"	6 - 25	1/4 - 1
	Angle	6 - 25	1/4 - 1
	Globe "T" Extended Bonnet	13 - 25	1/2 - 1
	Angle Extended Bonnet	13 - 25	1/2 - 1
Socket Weld (SW)	Globe "T"	6 - 65	1/4 - 2 1/2
	Angle	6 - 100	1/4 - 4
	Globe "Y"	32 - 100	1 1/4 - 4
	Globe "T" Extended Bonnet	13 - 65	1/2 - 2 1/2
	Angle Extended Bonnet	13 - 100	1/2 - 4
	Globe "Y" Extended Bonnet	75 - 100	3 - 4
Weld Neck (WN)	Globe "T"	75 - 100	3 - 4
	Angle	32 - 200	1 1/4 - 8
	Globe "Y"	32 - 200	1 1/4 - 8
	Globe "T" Extended Bonnet	75 - 100	3 - 4
	Angle Extended Bonnet	32 - 100	1 1/4 - 4
	Globe "Y" Extended Bonnet	100	4

General Information

Port Size		Flow Coefficient					
		Globe "T"		Globe "Y"		Angle	
mm	inch	Kv	Cv	Kv	Cv	Kv	Cv
6	1/4	2.2	2.6	—	—	3.1	3.6
10	3/8	3.5	4.1	—	—	4.7	5.5
13	1/2	6.2	7.2	—	—	6.9	8.0
20	3/4	12	14	—	—	15	17
25	1	19	22	—	—	23	27
32	1 1/4	26	30	41	47	30	35
38	1 1/2	35	43	46	53	40	46
50	2	52	61	80	93	73	85
65	2 1/2	89	103	131	153	128	149
75	3	98	114	179	208	184	214
100	4	173	202	292	340	301	350
125	5	—	—	716	718	635	739
150	6	—	—	788	916	811	943
200	8	—	—	1244	1446	1280	1489

Hand Shut-Off Valve
Globe "T" Body



Hand Shut-Off Valve
Angle Body



Hand Shut-Off Valve
Globe "Y" Body



Hand Expansion Valves (HEV)

General Information

Number of Turns	Angle Body															
	1/4"		3/8"		1/2"		3/4"		1"		1 1/4"		1 1/2"		2"	
	Kv	Cv	Kv	Cv	Kv	Cv	Kv	Cv	Kv	Cv	Kv	Cv	Kv	Cv	Kv	Cv
1	0.5	0.6	0.7	0.6	0.5	0.5	0.3	0.3	0.3	0.3	0.8	0.7	0.4	0.3	13	11
2	1.0	1.2	1.7	1.4	1.5	1.3	0.7	0.6	0.6	0.5	3.9	3.3	0.5	0.5	13	11
3	1.3	1.5	2.3	2.0	2.2	1.9	1.9	1.6	0.9	0.8	11	9.4	6.7	5.7	20	17
4	1.6	1.8	2.8	2.4	2.8	2.4	3.0	2.6	2.9	2.5	17	14	13	11	22	18
5	1.7	2.0	3.5	3.0	3.4	2.9	4.1	3.5	4.1	3.5	18	16	17	14	24	20
6	—	—	—	—	—	—	4.9	4.2	4.7	4.0	20	17	19	16	26	23
7	—	—	—	—	—	—	—	—	5.4	4.6	21	18	20	17	30	25
8	—	—	—	—	—	—	—	—	—	—	22	18	21	18	32	27
9	—	—	—	—	—	—	—	—	—	—	23	20	22	19	36	30
10	—	—	—	—	—	—	—	—	—	—	—	—	—	—	38	33
11	—	—	—	—	—	—	—	—	—	—	—	—	—	—	40	34
12	—	—	—	—	—	—	—	—	—	—	—	—	—	—	42	36
13	—	—	—	—	—	—	—	—	—	—	—	—	—	—	43	37
14	—	—	—	—	—	—	—	—	—	—	—	—	—	—	45	39

Number of Turns	Globe "Y" Body					
	1 1/4"		1 1/2"		2"	
	Kv	Cv	Kv	Cv	Kv	Cv
1	0.6	0.5	0.4	0.3	12	10
2	3.0	2.6	0.7	0.6	13	11
3	10	9.0	7.5	6.4	19	16
4	17	14	14	12	21	18
5	18	16	17	15	23	19
6	19	17	19	16	26	22
7	20	18	20	17	30	26
8	22	19	21	18	31	27
9	23	20	22	19	36	31
10	—	—	—	—	39	33
11	—	—	—	—	39	34
12	—	—	—	—	41	35
13	—	—	—	—	44	38
14	—	—	—	—	45	38
15	—	—	—	—	48	41

Liquid Overfeed Capacities - Globe "T" Body

R-717 (KW)

Port Size	Pressure Drop (bar)	Number of Turns														
		1	2	3	4	5	6	7	8	9	10	11	12	13	14	15
6mm	0.34	15	39	47	51	54										
	0.69	22	55	67	73	76										
	1.03	26	67	82	89	93	—	—	—	—	—	—	—	—	—	—
	1.38	30	78	94	103	107										
	2.07	37	95	115	126	131										
10mm	0.34	19	47	66	78	91										
	0.69	27	67	93	111	128										
	1.03	33	82	114	136	157	—	—	—	—	—	—	—	—	—	—
	1.38	38	94	132	157	181										
	2.07	46	115	162	192	222										
13mm	0.34	20	49	70	84	99										
	0.69	29	69	98	119	140										
	1.03	35	84	121	146	172	—	—	—	—	—	—	—	—	—	—
	1.38	41	97	139	168	199										
	2.07	50	119	171	206	243										
20mm	0.34	11	17	57	98	122	147									
	0.69	15	25	80	138	173	208									
	1.03	18	30	98	170	212	254	—	—	—	—	—	—	—	—	—
	1.38	21	35	113	196	244	294									
	2.07	26	43	139	240	299	360									
25mm	0.34	8.7	18	57	95	128	147									
	0.69	12	25	81	134	180	208									
	1.03	15	31	99	165	221	255	—	—	—	—	—	—	—	—	—
	1.38	17	36	115	190	255	294									
	2.07	21	44	140	233	313	361									
32mm	0.34	22	104	328	476	518	563	605	617	661	686					
	0.69	32	148	465	673	733	796	856	873	935	971					
	1.03	39	181	569	824	898	975	1049	1069	1145	1189	—	—	—	—	—
	1.38	45	209	657	951	1037	1126	1211	1234	1323	1373					
	2.07	55	256	805	1165	1270	1379	1483	1512	1620	1681					
40mm	0.34	383	472	580	660	736	803	845	922	958	980	1034	1062	1096	1117	1136
	0.69	542	668	821	933	1041	1135	1195	1304	1355	1386	1462	1502	1550	1579	1606
	1.03	664	818	1005	1142	1275	1390	1463	1598	1659	1698	1791	1840	1898	1934	1967
	1.38	766	945	1161	1319	1472	1605	1690	1845	1916	1961	2068	2125	2191	2233	2271
	2.07	939	1157	1422	1615	1803	1966	2069	2259	2346	2401	2533	2602	2684	2735	2782
50mm	0.34	394	508	578	682	770	843	946	987	1092	1137	1149	1174	1226	1235	1274
	0.69	558	718	817	964	1089	1192	1337	1396	1544	1608	1625	1661	1734	1746	1801
	1.03	683	879	1001	1181	1333	1459	1638	1710	1891	1969	1990	2034	2123	2139	2206
	1.38	789	1015	1156	1363	1539	1685	1891	1975	2184	2274	2298	2349	2452	2470	2547
	2.07	966	1243	1416	1670	1885	2064	2316	2418	2675	2785	2814	2877	3003	3025	3120

Capacities for R717 are based on -5°C liquid and -5°C evaporator temperature. For other evaporator temperatures, these values will change only slightly due to density and latent heat variations.

A recirculation rate of 4:1 was used to calculate the capacity tables. For other recirculation rates, divide 4 by the new recirculation rate and multiply values shown in table to arrive at new capacity.

Example: Calculate the capacity of 25mm port hand expansion valve at three turns with recirculation rate of 3:1 and a pressure drop of 1.03 bars.

Known: The capacity of a 25mm port hand expansion valve at three turns with a recirculation rate of 4:1 and a pressure drop of 1.03 bars is 99 kW.

$$(a) Q_{n:1} \text{ (kW)} = \frac{4}{\text{New Recirculation Rate (n)}} \times Q_{4:1} \text{ (kW)}$$

$$Q_{3:1} \text{ (kW)} = \frac{4}{3} \times 99 \text{ kW}$$

$$Q_{3:1} = 132 \text{ kW}$$

Liquid Overfeed Capacities - Globe "T" Body

R-717 (TONS)

Port Size	Pressure Drop (psi)	Number of Turns														
		1	2	3	4	5	6	7	8	9	10	11	12	13	14	15
1/4"	5	4.4	11	13	15	15										
	10	6.2	16	19	21	22										
	15	7.5	19	23	26	27	-	-	-	-	-	-	-	-	-	-
	20	8.7	22	27	29	31										
	30	11	27	33	36	38										
3/8"	5	5.4	13	19	22	26										
	10	7.6	19	27	32	37										
	15	9.3	23	33	39	45	-	-	-	-	-	-	-	-	-	-
	20	11	27	38	45	52										
	30	13	33	46	55	64										
1/2"	5	5.8	14	20	24	28										
	10	8.2	20	28	34	40										
	15	10	24	34	42	49	-	-	-	-	-	-	-	-	-	-
	20	12	28	40	48	57										
	30	14	34	49	59	70										
3/4"	5	3.0	5.0	16	28	35	42									
	10	4.3	7.0	23	40	49	59									
	15	5.2	8.6	28	49	61	73	-	-	-	-	-	-	-	-	-
	20	6.0	10	32	56	70	84									
	30	7.4	12	40	69	86	103									
1"	5	2.5	5.1	16	27	37	42									
	10	3.5	7.2	23	38	52	60									
	15	4.3	8.8	28	47	63	73	-	-	-	-	-	-	-	-	-
	20	5.0	10	33	54	73	84									
	30	6.1	12	40	67	89	103									
1 1/4"	5	6.4	30	94	136	148	161	173	177	189	196					
	10	9.1	42	133	192	210	228	245	250	268	278					
	15	11	52	163	236	257	279	300	306	328	340	-	-	-	-	-
	20	13	60	188	272	297	322	346	353	378	393					
	30	16	73	230	333	363	395	424	432	463	481					
1 1/2"	5	110	135	166	189	211	230	242	264	274	281	296	304	313	320	325
	10	155	191	235	267	298	325	342	373	388	397	418	430	443	452	459
	15	190	234	288	327	365	398	419	457	475	486	512	526	543	553	563
	20	219	270	332	377	421	459	483	528	548	561	592	608	627	639	650
	30	269	331	407	462	516	563	592	646	671	687	725	745	768	783	796
2"	5	113	145	165	195	220	241	271	282	312	325	329	336	351	353	364
	10	160	205	234	276	311	341	383	399	442	460	465	475	496	500	515
	15	195	252	286	338	381	418	469	489	541	563	569	582	607	612	631
	20	226	290	331	390	440	482	541	565	625	651	657	672	701	707	729
	30	276	356	405	478	539	591	663	692	765	797	805	823	859	865	893

Capacities for R717 are based on 20°F liquid and 20°F evaporator temperature. For other evaporator temperatures, these values will change only slightly due to density and latent heat variations.

A recirculation rate of 4:1 was used to calculate the capacity tables. For other recirculation rates, divide 4 by the new recirculation rate and multiply values shown in table to arrive at new capacity.

Example: Calculate the capacity of 1" port hand expansion valve at three turns with recirculation rate of 3:1 and a pressure drop of 15 psi.

Known: The capacity of a 1" port hand expansion valve at three turns with a recirculation rate of 4:1 and a pressure drop of 15 psi is 28 Tons.

$$(a) Q_{n,1} (kW) = \frac{4}{\text{New Recirculation Rate (n)}} \times Q_{4,1} (\text{Tons})$$

$$Q_{3,1} (kW) = \frac{4}{3} \times 28 \text{ Tons}$$

$$Q_{3,1} = 37 \text{ Tons}$$

HEVs

Liquid Overfeed Capacities - Globe "T" Body

R-22 (KW)

Port Size	Pressure Drop (bar)	Number of Turns														
		1	2	3	4	5	6	7	8	9	10	11	12	13	14	15
6mm	0.34	3.5	9.0	11	12	12										
	0.69	5.0	13	15	17	18										
	1.03	6.1	16	19	21	22	—	—	—	—	—	—	—	—	—	—
	1.38	7.1	18	22	24	25										
	2.07	8.6	22	27	29	30										
10mm	0.34	4.4	11	15	18	21										
	0.69	6.2	15	22	26	30										
	1.03	7.6	19	26	31	36	—	—	—	—	—	—	—	—	—	—
	1.38	8.7	22	31	36	42										
	2.07	11	27	37	44	51										
13mm	0.34	4.7	11	16	19	23										
	0.69	6.7	16	23	28	33										
	1.03	8.1	19	28	34	40	—	—	—	—	—	—	—	—	—	—
	1.38	9.4	23	32	39	46										
	2.07	12	28	39	48	56										
20mm	0.34	2.4	4.0	13	23	28	34									
	0.69	3.4	5.7	19	32	40	48									
	1.03	4.2	7.0	23	39	49	59	—	—	—	—	—	—	—	—	—
	1.38	4.9	8.1	26	45	57	68									
	2.07	6.0	9.9	32	56	69	83									
25mm	0.34	2.0	4.1	13	22	30	34									
	0.69	2.9	5.8	19	31	42	48									
	1.03	3.5	7.1	23	38	51	59	—	—	—	—	—	—	—	—	—
	1.38	4.0	8.2	27	44	59	68									
	2.07	4.9	10	33	54	72	84									
32mm	0.34	5.2	24	76	110	120	130	140	143	153	159					
	0.69	7.4	34	108	156	170	184	198	202	217	225					
	1.03	9.0	42	132	191	208	226	243	248	265	275	—	—	—	—	—
	1.38	10	48	152	220	240	261	280	286	306	318					
	2.07	13	59	186	270	294	319	344	350	375	389					
40mm	0.34	89	109	134	153	170	186	196	214	222	227	240	246	254	259	263
	0.69	126	155	190	216	241	263	277	302	314	321	339	348	359	366	372
	1.03	154	190	233	265	295	322	339	370	384	393	415	426	440	448	456
	1.38	178	219	269	306	341	372	391	427	444	454	479	492	508	517	526
	2.07	217	268	329	374	418	455	479	523	543	556	587	603	622	634	644
50mm	0.34	91	118	134	158	178	195	219	229	253	263	266	272	284	286	295
	0.69	129	166	189	223	252	276	310	323	358	372	376	385	402	405	417
	1.03	158	204	232	273	309	338	379	396	438	456	461	471	492	495	511
	1.38	183	235	268	316	357	390	438	457	506	527	532	544	568	572	590
	2.07	224	288	328	387	437	478	536	560	620	645	652	666	696	701	723

Capacities for R22 are based on -5°C liquid and -5°C evaporator temperature. For other evaporator temperatures, these values will change only slightly due to density and latent heat variations.

A recirculation rate of 4:1 was used to calculate the capacity tables. For other recirculation rates, divide 4 by the new recirculation rate and multiply values shown in table to arrive at new capacity.

Example: Calculate the capacity of 25mm port hand expansion valve at three turns with recirculation rate of 3:1 and a pressure drop of 1.03 bars.

Known: The capacity of a 25mm port hand expansion valve at three turns with a recirculation rate of 4:1 and a pressure drop of 1.03 bars is 23 kW.

$$(a) Q_{n:1} \text{ (kW)} = \frac{4}{\text{New Recirculation Rate (n)}} \times Q_{4:1} \text{ (kW)}$$

$$Q_{3:1} \text{ (kW)} = \frac{4}{3} \times 23 \text{ kW}$$

$$Q_{3:1} = 31 \text{ kW}$$

Liquid Overfeed Capacities - Globe "T" Body

R-22 (TONS)

Port Size	Pressure Drop (psi)	Number of Turns														
		1	2	3	4	5	6	7	8	9	10	11	12	13	14	15
1/4"	5	1.0	2.6	3.1	3.4	3.6										
	10	1.4	3.6	4.4	4.8	5.0										
	15	1.8	4.5	5.4	5.9	6.2	-	-	-	-	-	-	-	-	-	-
	20	2.0	5.2	6.3	6.8	7.1										
	30	2.5	6.3	7.7	8.4											
3/8"	5	1.3	3.1	4.4	5.2	6.0										
	10	1.8	4.4	6.2	7.4	8.5										
	15	2.2	5.4	7.6	9.0	10	-	-	-	-	-	-	-	-	-	-
	20	2.5	6.3	8.8	10	12										
	30	3.1	7.7	11	13	15										
1/2"	5	1.3	3.2	4.6	5.6	6.6										
	10	1.9	4.6	6.5	7.9	9.3										
	15	2.3	5.6	8.0	9.7	11	-	-	-	-	-	-	-	-	-	-
	20	2.7	6.5	9	11	13										
	30	3.3	7.9	11	14	16										
3/4"	5	0.7	1.2	3.8	6.5	8.1	9.8									
	10	1.0	1.6	5.3	9.2	11	14									
	15	1.2	2.0	6.5	11	14	17	-	-	-	-	-	-	-	-	-
	20	1.4	2.3	7.5	13	16	20									
	30	1.7	2.8	9.2	16	20	24									
1"	5	0.6	1.2	3.8	6.3	8.5	9.8									
	10	0.8	1.7	5.4	8.9	12	14									
	15	1.0	2.0	6.6	11	15	17	-	-	-	-	-	-	-	-	-
	20	1.2	2.4	7.6	13	17	20									
	30	1.4	2.9	9.3	15	21	24									
1 1/4"	5	1.5	6.9	22	32	34	37	40	41	44	46					
	10	2.1	9.8	31	45	49	53	57	58	62	64					
	15	2.6	12	38	55	60	65	70	71	76	79	-	-	-	-	-
	20	3.0	14	44	63	69	75	80	82	88	91					
	30	3.7	17	53	77	84	92	98	100	108	112					
1 1/2"	5	25	31	39	44	49	53	56	61	64	65	69	71	73	74	75
	10	36	44	55	62	69	75	79	87	90	92	97	100	103	105	107
	15	44	54	67	76	85	92	97	106	110	113	119	122	126	128	131
	20	51	63	77	88	98	107	112	123	127	130	137	141	146	148	151
	30	62	77	94	107	120	131	137	150	156	159	168	173	178	182	185
2"	5	26	34	38	45	51	56	63	66	73	76	76	78	81	82	85
	10	37	48	54	64	72	79	89	93	103	107	108	110	115	116	120
	15	45	58	66	78	89	97	109	114	126	131	132	135	141	142	147
	20	52	67	77	91	102	112	126	131	145	151	153	156	163	164	169
	30	64	83	94	111	125	137	154	161	178	185	187	191	199	201	207

Capacities for R22 are based on 20°F liquid and 20°F evaporator temperature. For other evaporator temperatures, these values will change only slightly due to density and latent heat variations.

A recirculation rate of 4:1 was used to calculate the capacity tables. For other recirculation rates, divide 4 by the new recirculation rate and multiply values shown in table to arrive at new capacity.

Example: Calculate the capacity of 1" port hand expansion valve at three turns with recirculation rate of 3:1 and a pressure drop of 15 psi.

Known: The capacity of a 1" port hand expansion valve at three turns with a recirculation rate of 4:1 and a pressure drop of 15 psi is 6.6 Tons.

$$(a) Q_{n,1} (kW) = \frac{4}{\text{New Recirculation Rate (n)}} \times Q_{4,1} (\text{Tons})$$

$$Q_{3:1} (kW) = \frac{4}{3} \times 6.6 \text{ Tons}$$

$$Q_{3:1} = 8.8 \text{ Tons}$$

HEVs

Liquid Overfeed Capacities - Globe "T" Body

R-134a (KW)

Port Size	Pressure Drop (bar)	Number of Turns														
		1	2	3	4	5	6	7	8	9	10	11	12	13	14	15
6mm	0.34	3.4	8.7	11	12	12										
	0.69	4.9	12	15	16	17										
	1.03	5.9	15	18	20	21	—	—	—	—	—	—	—	—	—	—
	1.38	6.9	17	21	23	24										
	2.07	8.4	21	26	28	30										
10mm	0.34	4.2	11	15	18	20										
	0.69	6.0	15	21	25	29										
	1.03	7.4	18	26	31	35	—	—	—	—	—	—	—	—	—	—
	1.38	8.5	21	30	35	41										
	2.07	10	26	36	43	50										
13mm	0.34	4.6	11	16	19	22										
	0.69	6.5	15	22	27	32										
	1.03	7.9	19	27	33	39	—	—	—	—	—	—	—	—	—	—
	1.38	9.2	22	31	38	45										
	2.07	11	27	38	46	55										
20mm	0.34	2.4	3.9	13	22	28	33									
	0.69	3.4	5.5	18	31	39	47									
	1.03	4.1	6.8	22	38	48	57	—	—	—	—	—	—	—	—	—
	1.38	4.7	7.8	25	44	55	66									
	2.07	5.8	9.6	31	54	67	81									
25mm	0.34	2.0	4.0	13	21	29	33									
	0.69	2.8	5.7	18	30	41	47									
	1.03	3.4	6.9	22	37	50	57	—	—	—	—	—	—	—	—	—
	1.38	3.9	8.0	26	43	58	66									
	2.07	4.8	9.8	32	52	70	81									
32mm	0.34	5.1	24	74	107	117	127	136	139	149	155					
	0.69	7.2	33	105	152	165	179	193	197	211	219					
	1.03	8.8	41	128	186	202	220	236	241	258	268	—	—	—	—	—
	1.38	10	47	148	214	234	254	273	278	298	309					
	2.07	12	58	181	263	286	311	334	341	365	379					
40mm	0.34	86	106	131	149	166	181	190	208	216	221	233	239	247	252	256
	0.69	122	151	185	210	235	256	269	294	305	312	330	339	349	356	362
	1.03	150	184	227	257	287	313	330	360	374	383	404	415	428	436	443
	1.38	173	213	262	297	332	362	381	416	432	442	466	479	494	503	512
	2.07	212	261	320	364	406	443	466	509	529	541	571	586	605	616	627
50mm	0.34	89	114	130	154	173	190	213	222	246	256	259	265	276	278	287
	0.69	126	162	184	217	245	269	301	315	348	362	366	374	391	394	406
	1.03	154	198	226	266	300	329	369	385	426	444	448	458	478	482	497
	1.38	178	229	260	307	347	380	426	445	492	512	518	529	553	557	574
	2.07	218	280	319	376	425	465	522	545	603	628	634	648	677	682	703

Capacities for R134a are based on -5°C liquid and -5°C evaporator temperature. For other evaporator temperatures, these values will change only slightly due to density and latent heat variations.

A recirculation rate of 4:1 was used to calculate the capacity tables. For other recirculation rates, divide 4 by the new recirculation rate and multiply values shown in table to arrive at new capacity.

Example: Calculate the capacity of 25mm port hand expansion valve at three turns with recirculation rate of 3:1 and a pressure drop of 1.03 bars.

Known: The capacity of a 25mm port hand expansion valve at three turns with a recirculation rate of 4:1 and a pressure drop of 1.03 bars is 22 kW.

$$(a) Q_{n:1} \text{ (kW)} = \frac{4}{\text{New Recirculation Rate (n)}} \times Q_{4:1} \text{ (kW)}$$

$$Q_{3:1} \text{ (kW)} = \frac{4}{3} \times 22 \text{ kW}$$

$$Q_{3:1} = 29 \text{ kW}$$

Liquid Overfeed Capacities - Globe "T" Body

R-134a (TONS)

Port Size	Pressure Drop (psi)	Number of Turns														
		1	2	3	4	5	6	7	8	9	10	11	12	13	14	15
1/4"	5	1.0	2.5	3.0	3.3	3.5										
	10	1.4	3.5	4.3	4.7	4.9										
	15	1.7	4.3	5.3	5.8	6.0	-	-	-	-	-	-	-	-	-	-
	20	2.0	5.0	6.1	6.7	6.9										
	30	2.4	6.1	7.5	8.1	8.5										
3/8"	5	1.2	3.0	4.3	5.1	5.9										
	10	1.7	4.3	6.0	7.2	8.3										
	15	2.1	5.3	7.4	8.8	10	-	-	-	-	-	-	-	-	-	-
	20	2.4	6.1	8.5	10	12										
	30	3.0	7.5	10	12	14										
1/2"	5	1.3	3.1	4.5	5.4	6.4										
	10	1.9	4.4	6.4	7.7	9.1										
	15	2.3	5.4	7.8	9.4	11	-	-	-	-	-	-	-	-	-	-
	20	2.6	6.3	9.0	11	13										
	30	3.2	7.7	11	13	16										
3/4"	5	0.7	1.1	3.7	6.3	7.9	9.5									
	10	1.0	1.6	5.2	8.9	11	13									
	15	1.2	1.9	6.3	11	14	16	-	-	-	-	-	-	-	-	-
	20	1.4	2.2	7.3	13	16	19									
	30	1.7	2.8	9.0	15	19	23									
1"	5	0.6	1.1	3.7	6.1	8.2	9.5									
	10	0.8	1.6	5.2	8.7	12	13									
	15	1.0	2.0	6.4	11	14	16	-	-	-	-	-	-	-	-	-
	20	1.1	2.3	7.4	12	16	19									
	30	1.4	2.8	9.1	15	20	23									
1 1/4"	5	1.5	6.7	21	31	33	36	39	40	43	44					
	10	2.1	9.5	30	43	47	51	55	56	60	63					
	15	2.5	12	37	53	58	63	68	69	74	77	-	-	-	-	-
	20	2.9	13	42	61	67	73	78	80	85	89					
	30	3.6	17	52	75	82	89	96	98	105	109					
1 1/2"	5	25	31	37	43	48	52	55	60	62	63	67	69	71	72	73
	10	35	43	53	60	67	73	77	84	88	90	94	97	100	102	104
	15	43	53	65	74	82	90	95	103	107	110	116	119	123	125	127
	20	50	61	75	85	95	104	109	119	124	127	134	137	142	144	147
	30	61	75	92	104	116	127	134	146	152	155	164	168	173	177	180
2"	5	25	33	37	44	50	54	61	64	71	73	74	76	79	80	82
	10	36	46	53	62	70	77	86	90	100	104	105	107	112	113	116
	15	44	57	65	76	86	94	106	110	122	127	129	131	137	138	143
	20	51	66	75	88	99	109	122	128	141	147	148	152	158	160	165
	30	62	80	91	108	122	133	150	156	173	180	182	186	194	195	202

Capacities for R134a are based on 20°F liquid and 20°F evaporator temperature. For other evaporator temperatures, these values will change only slightly due to density and latent heat variations.

A recirculation rate of 4:1 was used to calculate the capacity tables. For other recirculation rates, divide 4 by the new recirculation rate and multiply values shown in table to arrive at new capacity.

Example: Calculate the capacity of 1" port hand expansion valve at three turns with recirculation rate of 3:1 and a pressure drop of 15 psi.

Known: The capacity of a 1" port hand expansion valve at three turns with a recirculation rate of 4:1 and a pressure drop of 15 psi is 6.4 Tons.

$$(a) Q_{n,1} \text{ (kW)} = \frac{4}{\text{New Recirculation Rate (n)}} \times Q_{4,1} \text{ (Tons)}$$

$$Q_{3,1} \text{ (kW)} = \frac{4}{3} \times 6.4 \text{ Tons}$$

$$Q_{3,1} = 8.5 \text{ Tons}$$

HEVs

Liquid Overfeed Capacities - Globe "T" Body

R-404a (KW)

Port Size	Pressure Drop (bar)	Number of Turns														
		1	2	3	4	5	6	7	8	9	10	11	12	13	14	15
6mm	0.34	2.7	6.9	8.4	9.2	9.6										
	0.69	3.9	9.8	12	13	14										
	1.03	4.7	12	15	16	17	—	—	—	—	—	—	—	—	—	—
	1.38	5.5	14	17	18	19										
	2.07	6.7	17	21	23	24										
10mm	0.34	3.4	8.4	12	14	16										
	0.69	4.8	12	17	20	23										
	1.03	5.8	15	20	24	28	—	—	—	—	—	—	—	—	—	—
	1.38	6.7	17	24	28	32										
	2.07	8.3	21	29	34	40										
13mm	0.34	3.6	8.7	12	15	18										
	0.69	5.1	12	18	21	25										
	1.03	6.3	15	22	26	31	—	—	—	—	—	—	—	—	—	—
	1.38	7.3	17	25	30	36										
	2.07	8.9	21	31	37	44										
20mm	0.34	1.9	3.1	10	18	22	26									
	0.69	2.7	4.4	14	25	31	37									
	1.03	3.3	5.4	18	30	38	46	—	—	—	—	—	—	—	—	—
	1.38	3.8	6.2	20	35	44	53									
	2.07	4.6	7.6	25	43	54	64									
25mm	0.34	1.6	3.2	10	17	23	26									
	0.69	2.2	4.5	14	24	32	37									
	1.03	2.7	5.5	18	29	40	46	—	—	—	—	—	—	—	—	—
	1.38	3.1	6.4	21	34	46	53									
	2.07	3.8	7.8	25	42	56	65									
32mm	0.34	4.0	19	59	85	93	101	108	110	118	123					
	0.69	5.7	26	83	120	131	143	153	156	167	174					
	1.03	7.0	32	102	147	161	175	188	191	205	213	—	—	—	—	—
	1.38	8.0	37	118	170	186	202	217	221	237	246					
	2.07	9.9	46	144	209	227	247	265	270	290	301					
40mm	0.34	69	85	104	118	132	144	151	165	171	175	185	190	196	200	203
	0.69	97	120	147	167	186	203	214	233	242	248	262	269	277	283	287
	1.03	119	146	180	204	228	249	262	286	297	304	321	329	340	346	352
	1.38	137	169	208	236	263	287	302	330	343	351	370	380	392	400	406
	2.07	168	207	254	289	323	352	370	404	420	430	453	466	480	490	498
50mm	0.34	71	91	103	122	138	151	169	177	195	203	206	210	219	221	228
	0.69	100	128	146	173	195	213	239	250	276	288	291	297	310	313	322
	1.03	122	157	179	211	239	261	293	306	338	352	356	364	380	383	395
	1.38	141	182	207	244	275	302	338	353	391	407	411	420	439	442	456
	2.07	173	223	253	299	337	369	414	433	479	498	504	515	537	541	558

Capacities for R404a are based on -5°C liquid and -5°C evaporator temperature. For other evaporator temperatures, these values will change only slightly due to density and latent heat variations.

A recirculation rate of 4:1 was used to calculate the capacity tables. For other recirculation rates, divide 4 by the new recirculation rate and multiply values shown in table to arrive at new capacity.

Example: Calculate the capacity of 25mm port hand expansion valve at three turns with recirculation rate of 3:1 and a pressure drop of 1.03 bars.

Known: The capacity of a 25mm port hand expansion valve at three turns with a recirculation rate of 4:1 and a pressure drop of 1.03 bars is 18 kW.

$$(a) Q_{n:1} \text{ (kW)} = \frac{4}{\text{New Recirculation Rate (n)}} \times Q_{4:1} \text{ (kW)}$$

$$Q_{3:1} \text{ (kW)} = \frac{4}{3} \times 18 \text{ kW}$$

$$Q_{3:1} = 24 \text{ kW}$$

Liquid Overfeed Capacities - Globe "T" Body

R-404a (TONS)

Port Size	Pressure Drop (psi)	Number of Turns														
		1	2	3	4	5	6	7	8	9	10	11	12	13	14	15
1/4"	5	0.8	2.0	2.4	2.6	2.8										
	10	1.1	2.8	3.4	3.7	3.9										
	15	1.4	3.5	4.2	4.6	4.8	-	-	-	-	-	-	-	-	-	-
	20	1.6	4.0	4.8	5.3	5.5										
	30	1.9	4.9	5.9	6.5	6.8										
3/8"	5	1.0	2.4	3.4	4.0	4.7										
	10	1.4	3.4	4.8	5.7	6.6										
	15	1.7	4.2	5.9	7.0	8.1	-	-	-	-	-	-	-	-	-	-
	20	1.9	4.8	6.8	8.1	9.3										
	30	2.4	5.9	8.3	9.9	11										
1/2"	5	1.0	2.5	3.6	4.3	5.1										
	10	1.5	3.5	5.1	6.1	7.2										
	15	1.8	4.3	6.2	7.5	8.9	-	-	-	-	-	-	-	-	-	-
	20	2.1	5.0	7.2	8.7	10										
	30	2.6	6.1	8.8	11	13										
3/4"	5	0.5	0.9	2.9	5.0	6.3	7.6									
	10	0.8	1.3	4.1	7.1	8.9	11									
	15	0.9	1.6	5.0	8.7	11	13	-	-	-	-	-	-	-	-	-
	20	1.1	1.8	5.8	10	13	15									
	30	1.3	2.2	7.1	12	15	19									
1"	5	0.4	0.9	2.9	4.9	6.6	7.6									
	10	0.6	1.3	4.2	6.9	9.3	11									
	15	0.8	1.6	5.1	8.5	11	13	-	-	-	-	-	-	-	-	-
	20	0.9	1.8	5.9	9.8	13	15									
	30	1.1	2.2	7.2	12	16	19									
1 1/4"	5	1.2	5.4	17	24	27	29	31	32	34	35					
	10	1.6	7.6	24	35	38	41	44	45	48	50					
	15	2.0	9.3	29	42	46	50	54	55	59	61	-	-	-	-	-
	20	2.3	11	34	49	53	58	62	63	68	71					
	30	2.8	13	41	60	65	71	76	78	83	86					
1 1/2"	5	20	24	30	34	38	41	43	47	49	50	53	55	56	57	58
	10	28	34	42	48	54	58	61	67	70	71	75	77	80	81	83
	15	34	42	52	59	66	72	75	82	85	87	92	95	98	99	101
	20	39	49	60	68	76	83	87	95	99	101	106	109	113	115	117
	30	48	60	73	83	93	101	106	116	121	124	130	134	138	141	143
2"	5	20	26	30	35	40	43	49	51	56	58	59	60	63	64	66
	10	29	37	42	50	56	61	69	72	79	83	84	85	89	90	93
	15	35	45	51	61	69	75	84	88	97	101	102	105	109	110	113
	20	41	52	59	70	79	87	97	102	112	117	118	121	126	127	131
	30	50	64	73	86	97	106	119	124	138	143	145	148	154	156	160

Capacities for R404a are based on 20°F liquid and 20°F evaporator temperature. For other evaporator temperatures, these values will change only slightly due to density and latent heat variations.

A recirculation rate of 4:1 was used to calculate the capacity tables. For other recirculation rates, divide 4 by the new recirculation rate and multiply values shown in table to arrive at new capacity.

Example: Calculate the capacity of 1" port hand expansion valve at three turns with recirculation rate of 3:1 and a pressure drop of 15 psi.

Known: The capacity of a 1" port hand expansion valve at three turns with a recirculation rate of 4:1 and a pressure drop of 15 psi is 5.1 Tons.

$$(a) Q_{n,1} (kW) = \frac{4}{\text{New Recirculation Rate (n)}} \times Q_{4,1} (\text{Tons})$$

$$Q_{3,1} (kW) = \frac{4}{3} \times 5.1 \text{ Tons}$$

$$Q_{3,1} = 6.8 \text{ Tons}$$

HEVs

Liquid Overfeed Capacities - Globe "T" Body

R-410a (KW)

Port Size	Pressure Drop (bar)	Number of Turns														
		1	2	3	4	5	6	7	8	9	10	11	12	13	14	15
6mm	0.34	3.7	9.4	11	12	13										
	0.69	5.2	13	16	18	18										
	1.03	6.4	16	20	21	22	—	—	—	—	—	—	—	—	—	—
	1.38	7.3	19	23	25	26										
	2.07	9.0	23	28	30	32										
10mm	0.34	4.5	11	16	19	22										
	0.69	6.4	16	22	27	31										
	1.03	7.9	20	28	33	38	—	—	—	—	—	—	—	—	—	—
	1.38	9.1	23	32	38	44										
	2.07	11	28	39	46	54										
13mm	0.34	4.9	12	17	20	24										
	0.69	6.9	17	24	29	34										
	1.03	8.5	20	29	35	41	—	—	—	—	—	—	—	—	—	—
	1.38	9.8	23	34	41	48										
	2.07	12	29	41	50	59										
20mm	0.34	2.5	4.2	14	24	29	35									
	0.69	3.6	5.9	19	33	42	50									
	1.03	4.4	7.3	24	41	51	61	—	—	—	—	—	—	—	—	—
	1.38	5.1	8.4	27	47	59	71									
	2.07	6.2	10	33	58	72	87									
25mm	0.34	2.1	4.3	14	23	31	35									
	0.69	3.0	6.1	20	32	44	50									
	1.03	3.6	7.4	24	40	53	61	—	—	—	—	—	—	—	—	—
	1.38	4.2	8.6	28	46	62	71									
	2.07	5.1	10	34	56	75	87									
32mm	5.4	25	79	115	125	136	146	149	159	165						
	7.7	36	112	162	177	192	206	210	225	234						
	9.4	44	137	199	217	235	253	258	276	287	—	—	—	—	—	—
	11	50	158	229	250	272	292	298	319	331						
	13	62	194	281	306	333	358	364	391	405						
40mm	0.34	92	114	140	159	177	194	204	222	231	236	249	256	264	269	274
	0.69	131	161	198	225	251	274	288	314	327	334	353	362	374	381	387
	1.03	160	197	242	275	307	335	353	385	400	409	432	444	458	466	474
	1.38	185	228	280	318	355	387	407	445	462	473	499	512	528	538	548
	2.07	226	279	343	389	435	474	499	545	566	579	611	627	647	659	671
50mm	0.34	95	122	139	164	186	203	228	238	263	274	277	283	296	298	307
	0.69	135	173	197	232	262	287	322	337	372	388	392	400	418	421	434
	1.03	165	212	241	285	321	352	395	412	456	475	480	490	512	516	532
	1.38	190	245	279	329	371	406	456	476	527	548	554	566	591	595	614
	2.07	233	300	341	403	455	498	558	583	645	671	679	694	724	729	752

Capacities for R410a are based on -5°C liquid and -5°C evaporator temperature. For other evaporator temperatures, these values will change only slightly due to density and latent heat variations.

A recirculation rate of 4:1 was used to calculate the capacity tables. For other recirculation rates, divide 4 by the new recirculation rate and multiply values shown in table to arrive at new capacity.

Example: Calculate the capacity of 25mm port hand expansion valve at three turns with recirculation rate of 3:1 and a pressure drop of 1.03 bars.

Known: The capacity of a 25mm port hand expansion valve at three turns with a recirculation rate of 4:1 and a pressure drop of 1.03 bars is 24 kW.

$$(a) Q_{n:1} \text{ (kW)} = \frac{4}{\text{New Recirculation Rate (n)}} \times Q_{4:1} \text{ (kW)}$$

$$Q_{3:1} \text{ (kW)} = \frac{4}{3} \times 24 \text{ kW}$$

$$Q_{3:1} = 32 \text{ kW}$$

Liquid Overfeed Capacities - Globe "T" Body

R-410a (TONS)

Port Size	Pressure Drop (psi)	Number of Turns														
		1	2	3	4	5	6	7	8	9	10	11	12	13	14	15
1/4"	5	1.1	2.7	3.3	3.6	3.7										
	10	1.5	3.8	4.6	5.0	5.3										
	15	1.8	4.7	5.7	6.2	6.4	-	-	-	-	-	-	-	-	-	-
	20	2.1	5.4	6.5	7.1	7.4										
	30	2.6	6.6	8.0	8.7											
3/8"	5	1.3	3.3	4.6	5.4	6.3										
	10	1.8	4.6	6.5	7.7	8.9										
	15	2.3	5.7	7.9	9.4	11	-	-	-	-	-	-	-	-	-	-
	20	2.6	6.5	9.1	11	13										
	30	3.2	8.0	11	13	15										
1/2"	5	1.4	3.4	4.8	5.8	6.9										
	10	2.0	4.8	6.8	8.2	9.7										
	15	2.4	5.8	8.4	10	12	-	-	-	-	-	-	-	-	-	-
	20	2.8	6.7	9.7	12	14										
	30	3.4	8.2	12	14	17										
3/4"	5	0.7	1.2	3.9	6.8	8.5	10									
	10	1.0	1.7	5.5	9.6	12	14									
	15	1.3	2.1	6.8	12	15	18	-	-	-	-	-	-	-	-	-
	20	1.5	2.4	7.8	14	17	20									
	30	1.8	3.0	9.6	17	21	25									
1"	5	0.6	1.2	4.0	6.6	8.8	10									
	10	0.9	1.7	5.6	9.3	13	14									
	15	1.0	2.1	6.9	11	15	18	-	-	-	-	-	-	-	-	-
	20	1.2	2.5	7.9	13	18	20									
	30	1.5	3.0	9.7	16	22	25									
1 1/4"	5	1.6	7.2	23	33	36	39	42	43	46	48					
	10	2.2	10	32	47	51	55	59	60	65	67					
	15	2.7	13	39	57	62	68	73	74	79	82	-	-	-	-	-
	20	3.1	14	46	66	72	78	84	86	92	95					
	30	3.8	18	56	81	88	96	103	105	112	117					
1 1/2"	5	27	33	40	46	51	56	59	64	66	68	72	74	76	77	79
	10	38	46	57	65	72	79	83	90	94	96	101	104	107	109	111
	15	46	57	70	79	88	96	101	111	115	118	124	128	132	134	136
	20	53	65	80	91	102	111	117	128	133	136	143	147	152	155	157
	30	65	80	99	112	125	136	143	157	163	166	176	180	186	190	193
2"	5	27	35	40	47	53	58	66	68	76	79	80	81	85	86	88
	10	39	50	57	67	75	83	93	97	107	111	113	115	120	121	125
	15	47	61	69	82	92	101	114	119	131	137	138	141	147	148	153
	20	55	70	80	95	107	117	131	137	151	158	159	163	170	171	177
	30	67	86	98	116	131	143	161	168	185	193	195	199	208	210	216

Capacities for R410a are based on 20°F liquid and 20°F evaporator temperature. For other evaporator temperatures, these values will change only slightly due to density and latent heat variations.

A recirculation rate of 4:1 was used to calculate the capacity tables. For other recirculation rates, divide 4 by the new recirculation rate and multiply values shown in table to arrive at new capacity.

Example: Calculate the capacity of 1" port hand expansion valve at three turns with recirculation rate of 3:1 and a pressure drop of 15 psi.

Known: The capacity of a 1" port hand expansion valve at three turns with a recirculation rate of 4:1 and a pressure drop of 15 psi is 6.9 Tons.

$$(a) Q_{n:1} \text{ (kW)} = \frac{4}{\text{New Recirculation Rate (n)}} \times Q_{4:1} \text{ (Tons)}$$

$$Q_{3:1} \text{ (kW)} = \frac{4}{3} \times 6.9 \text{ Tons}$$

$$Q_{3:1} = 9.2 \text{ Tons}$$

Liquid Overfeed Capacities - Globe "T" Body

R-507a (KW)

Port Size	Pressure Drop (bar)	Number of Turns														
		1	2	3	4	5	6	7	8	9	10	11	12	13	14	15
6mm	0.34	2.7	6.8	8.3	9.0	9.4										
	0.69	3.8	9.6	12	13	13										
	1.03	4.6	12	14	16	16	—	—	—	—	—	—	—	—	—	—
	1.38	5.3	14	17	18	19										
	2.07	6.5	17	20	22	23										
10mm	0.34	3.3	8.3	12	14	16										
	0.69	4.7	12	16	19	22										
	1.03	5.7	14	20	24	28	—	—	—	—	—	—	—	—	—	—
	1.38	6.6	17	23	27	32										
	2.07	8.1	20	28	34	39										
13mm	0.34	3.6	8.5	12	15	17										
	0.69	5.0	12	17	21	25										
	1.03	6.2	15	21	26	30	—	—	—	—	—	—	—	—	—	—
	1.38	7.1	17	24	30	35										
	2.07	8.7	21	30	36	43										
20mm	0.34	1.8	3.1	9.9	17	21	26									
	0.69	2.6	4.3	14	24	30	36									
	1.03	3.2	5.3	17	30	37	45	—	—	—	—	—	—	—	—	—
	1.38	3.7	6.1	20	34	43	52									
	2.07	4.5	7.5	24	42	53	63									
25mm	0.34	1.5	3.1	10	17	22	26									
	0.69	2.2	4.4	14	24	32	37									
	1.03	2.6	5.4	17	29	39	45	—	—	—	—	—	—	—	—	—
	1.38	3.1	6.2	20	33	45	52									
	2.07	3.7	7.6	25	41	55	63									
32mm	0.34	3.9	18	58	83	91	99	106	108	116	120					
	0.69	5.6	26	82	118	129	140	150	153	164	170					
	1.03	5.8	32	100	145	158	171	184	188	201	209	—	—	—	—	—
	1.38	7.9	37	115	167	182	198	213	217	232	241					
	2.07	9.7	45	141	204	223	242	260	265	284	295					
40mm	0.34	67	83	102	116	129	141	148	162	168	172	181	186	192	196	199
	0.69	95	117	144	164	183	199	210	229	238	243	257	264	272	277	282
	1.03	116	144	176	200	224	244	257	280	291	298	314	323	333	339	345
	1.38	135	166	204	231	258	282	297	324	336	344	363	373	385	392	399
	2.07	165	203	250	284	316	345	363	397	412	421	445	457	471	480	488
50mm	0.34	69	89	101	120	135	148	166	173	192	200	202	206	215	217	224
	0.69	98	126	143	169	191	209	235	245	271	282	285	291	304	307	316
	1.03	120	154	176	207	234	256	287	300	332	346	349	357	373	375	387
	1.38	138	178	203	239	270	296	332	347	383	399	403	412	430	433	447
	2.07	170	218	248	293	331	362	407	424	469	489	494	505	527	531	548

Capacities for R507a are based on -5°C liquid and -5°C evaporator temperature. For other evaporator temperatures, these values will change only slightly due to density and latent heat variations.

A recirculation rate of 4:1 was used to calculate the capacity tables. For other recirculation rates, divide 4 by the new recirculation rate and multiply values shown in table to arrive at new capacity.

Example: Calculate the capacity of 25mm port hand expansion valve at three turns with recirculation rate of 3:1 and a pressure drop of 1.03 bars.

Known: The capacity of a 25mm port hand expansion valve at three turns with a recirculation rate of 4:1 and a pressure drop of 1.03 bars is 17 kW.

$$(a) Q_{n:1} \text{ (kW)} = \frac{4}{\text{New Recirculation Rate (n)}} \times Q_{4:1} \text{ (kW)}$$

$$Q_{3:1} \text{ (kW)} = \frac{4}{3} \times 17 \text{ kW}$$

$$Q_{3:1} = 23 \text{ kW}$$

Liquid Overfeed Capacities - Globe "T" Body

R-507a (TONS)

Port Size	Pressure Drop (psi)	Number of Turns														
		1	2	3	4	5	6	7	8	9	10	11	12	13	14	15
1/4"	5	0.8	2.0	2.4	2.6	2.7										
	10	1.1	2.8	3.4	3.7	3.8										
	15	1.3	3.4	4.1	4.5	4.7	-	-	-	-	-	-	-	-	-	-
	20	1.5	3.9	4.8	5.2	5.4										
	30	1.9	4.8	5.8	6.4	6.6										
3/8"	5	1.0	2.4	3.3	4.0	4.6										
	10	1.3	3.4	4.7	5.6	6.5										
	15	1.6	4.1	5.8	6.8	7.9	-	-	-	-	-	-	-	-	-	-
	20	1.9	4.8	6.7	7.9	9.1										
	30	2.3	5.8	8.2	9.7	11										
1/2"	5	1.0	2.5	3.5	4.2	5.0										
	10	1.4	3.5	5.0	6.0	7.1										
	15	1.8	4.2	6.1	7.4	8.7	-	-	-	-	-	-	-	-	-	-
	20	2.0	4.9	7.0	8.5	10										
	30	2.5	6.0	8.6	10	12										
3/4"	5	0.5	0.9	2.9	4.9	6.2	7.4									
	10	0.8	1.2	4.0	7.0	8.7	10									
	15	0.9	1.5	4.9	8.6	11	13	-	-	-	-	-	-	-	-	-
	20	1.1	1.8	5.7	9.9	12	15									
	30	1.3	2.2	7.0	12	15	18									
1"	5	0.4	0.9	2.9	4.8	6.4	7.4									
	10	0.6	1.3	4.1	6.8	9.1	11									
	15	0.8	1.6	5.0	8.3	11	13	-	-	-	-	-	-	-	-	-
	20	0.9	1.8	5.8	9.6	13	15									
	30	1.1	2.2	7.1	12	16	18									
1 1/4"	5	1.1	5.3	17	24	26	28	31	31	33	35					
	10	1.6	7.5	23	34	37	40	43	44	47	49					
	15	2.0	9.1	29	42	45	49	53	54	58	60	-	-	-	-	-
	20	2.3	11	33	48	52	57	61	62	67	69					
	30	2.8	13	41	59	64	70	75	76	82	85					
1 1/2"	5	19	24	29	33	37	41	43	47	48	49	52	54	55	56	57
	10	27	34	41	47	53	57	60	66	68	70	74	76	78	80	81
	15	33	41	51	58	64	70	74	81	84	86	90	93	96	98	99
	20	39	48	59	67	74	81	85	93	97	99	104	107	111	113	115
	30	47	58	72	82	91	99	104	114	118	121	128	131	135	138	140
2"	5	20	26	29	34	39	43	48	50	55	57	58	59	62	62	64
	10	28	36	41	49	55	60	67	70	78	81	82	84	87	88	91
	15	34	44	51	60	67	74	83	86	95	99	100	103	107	108	111
	20	40	51	58	69	78	85	95	100	110	115	116	119	124	125	129
	30	49	63	71	84	95	104	117	122	135	141	142	145	152	153	157

Capacities for R507a are based on 20°F liquid and 20°F evaporator temperature. For other evaporator temperatures, these values will change only slightly due to density and latent heat variations.

A recirculation rate of 4:1 was used to calculate the capacity tables. For other recirculation rates, divide 4 by the new recirculation rate and multiply values shown in table to arrive at new capacity.

Example: Calculate the capacity of 1" port hand expansion valve at three turns with recirculation rate of 3:1 and a pressure drop of 15 psi.

Known: The capacity of a 1" port hand expansion valve at three turns with a recirculation rate of 4:1 and a pressure drop of 15 psi is 5.0 Tons.

$$(a) Q_{n,1} (kW) = \frac{4}{\text{New Recirculation Rate (n)}} \times Q_{4,1} (\text{Tons})$$

$$Q_{3,1} (kW) = \frac{4}{3} \times 5.0 \text{ Tons}$$

$$Q_{3,1} = 6.7 \text{ Tons}$$

Liquid Overfeed Capacities - Angle Body

R-717 (KW)

Port Size	Pressure Drop (bar)	Number of Turns													
		1	2	3	4	5	6	7	8	9	10	11	12	13	14
6mm	0.34	22	44	56	67	74									
	0.69	31	62	79	94	104									
	1.03	38	75	97	116	127	—	—	—	—	—	—	—	—	—
	1.38	44	87	112	133	147									
	2.07	54	107	137	163	180									
10mm	0.34	23	52	71	87	107									
	0.69	33	74	100	123	152									
	1.03	40	90	123	151	186	—	—	—	—	—	—	—	—	—
	1.38	46	104	142	174	215									
	2.07	57	128	174	213	263									
13mm	0.34	17	46	69	87	105									
	0.69	24	65	97	123	149									
	1.03	29	80	119	151	182	—	—	—	—	—	—	—	—	—
	1.38	33	92	137	174	210									
	2.07	41	113	168	213	258									
20mm	0.34	11	20	59	94	126	151								
	0.69	15	29	84	133	178	213								
	1.03	18	35	102	163	218	261	—	—	—	—	—	—	—	—
	1.38	21	41	118	189	252	302								
	2.07	26	50	145	231	308	369								
25mm	0.34	11	20	28	91	126	145								
	0.69	15	28	40	128	178	205								
	1.03	18	34	49	157	219	251	—	—	—	—	—	—	—	—
	1.38	21	39	57	181	252	290								
	2.07	26	48	69	222	309	355								
32mm	0.34	25	120	341	523	573	634	642	669	728					
	0.69	35	170	482	739	810	896	909	947	1030					
	1.03	43	208	590	906	992	1098	1113	1159	1261	—	—	—	—	—
	1.38	50	241	682	1046	1146	1268	1285	1339	1456					
	2.07	61	295	835	1281	1403	1552	1574	1639	1783					
40mm	0.34	11	17	207	404	516	587	627	661	678					
	0.69	16	24	293	571	729	830	886	935	958					
	1.03	19	30	359	700	893	1016	1085	1145	1174	—	—	—	—	—
	1.38	22	34	415	808	1031	1173	1253	1323	1355					
	2.07	28	42	508	989	1263	1437	1535	1620	1660					
50mm	0.34	402	415	613	669	741	821	919	994	1105	1191	1241	1307	1327	1401
	0.69	568	587	867	946	1049	1161	1300	1406	1562	1685	1756	1848	1877	1982
	1.03	696	718	1061	1158	1284	1422	1592	1722	1913	2064	2150	2263	2299	2427
	1.38	803	830	1225	1337	1483	1642	1838	1988	2209	2383	2483	2613	2655	2803
	2.07	984	1016	1501	1638	1816	2012	2251	2435	2706	2918	3041	3201	3251	3433

Capacities for R717 are based on -5°C liquid and -5°C evaporator temperature. For other evaporator temperatures, these values will change only slightly due to density and latent heat variations.

A recirculation rate of 4:1 was used to calculate the capacity tables. For other recirculation rates, divide 4 by the new recirculation rate and multiply values shown in table to arrive at new capacity.

Example: Calculate the capacity of 25mm port hand expansion valve at three turns with recirculation rate of 3:1 and a pressure drop of 1.03 bars.

Known: The capacity of a 25mm port hand expansion valve at three turns with a recirculation rate of 4:1 and a pressure drop of 1.03 bars is 49 kW.

$$(a) Q_{n:1} \text{ (kW)} = \frac{4}{\text{New Recirculation Rate (n)}} \times Q_{4:1} \text{ (kW)}$$

$$Q_{3:1} \text{ (kW)} = \frac{4}{3} \times 49 \text{ kW}$$

$$Q_{3:1} = 65 \text{ kW}$$

Liquid Overfeed Capacities - Angle Body

R-717 (TONS)

Port Size	Pressure Drop (psi)	Number of Turns													
		1	2	3	4	5	6	7	8	9	10	11	12	13	14
1/4"	5	6.3	12	16	19	21									
	10	8.9	18	23	27	30									
	15	11	22	28	33	36	-	-	-	-	-	-	-	-	-
	20	13	25	32	38	42									
	30	16	30	39	47	52									
3/8"	5	6.6	15	20	25	31									
	10	9.4	21	29	35	43									
	15	11	26	35	43	53	-	-	-	-	-	-	-	-	-
	20	13	30	41	50	61									
	30	16	37	50	61	75									
1/2"	5	4.8	13	20	25	30									
	10	6.7	19	28	35	43									
	15	8.3	23	34	43	52	-	-	-	-	-	-	-	-	-
	20	9.5	26	39	50	60									
	30	12	32	48	61	74									
3/4"	5	3.0	5.8	17	27	36	43								
	10	4.3	8.2	24	38	51	61								
	15	5.2	10	29	47	62	75	-	-	-	-	-	-	-	-
	20	6.0	12	34	54	72	86								
	30	7.4	14	41	66	88	106								
1"	5	3.0	5.6	8.1	26	36	41								
	10	4.3	7.9	11	37	51	59								
	15	5.2	9.7	14	45	63	72	-	-	-	-	-	-	-	-
	20	6.0	11	16	52	72	83								
	30	7.4	14	20	64	88	102								
1 1/4"	5	7.2	34	98	150	164	181	184	191	208	212				
	10	10	49	138	212	232	256	260	271	295	299				
	15	12	60	169	259	284	314	318	332	361	367	-	-	-	-
	20	14	69	195	299	328	363	368	383	417	423				
	30	18	84	239	366	401	444	450	469	510	518				
1 1/2"	5	3.2	4.9	59	116	148	168	179	189	194	197				
	10	4.5	6.9	84	163	209	237	254	268	274	278				
	15	5.6	8.4	103	200	255	291	310	328	336	341	-	-	-	-
	20	6.4	9.8	119	231	295	336	359	378	388	394				
	30	7.9	12	145	283	361	411	439	463	475	482				
2"	5	115	119	175	191	212	235	263	284	316	341	355	374	380	401
	10	163	168	248	271	300	332	372	402	447	482	502	529	537	567
	15	199	206	304	331	367	407	455	493	547	590	615	648	658	694
	20	230	237	351	383	424	470	526	569	632	682	710	748	760	802
	30	282	291	429	469	520	576	644	697	774	835	870	916	930	982

Capacities for R717 are based on 20°F liquid and 20°F evaporator temperature. For other evaporator temperatures, these values will change only slightly due to density and latent heat variations.

A recirculation rate of 4:1 was used to calculate the capacity tables. For other recirculation rates, divide 4 by the new recirculation rate and multiply values shown in table to arrive at new capacity.

Example: Calculate the capacity of 1" port hand expansion valve at three turns with recirculation rate of 3:1 and a pressure drop of 15 psi.

Known: The capacity of a 1" port hand expansion valve at three turns with a recirculation rate of 4:1 and a pressure drop of 15 psi is 14 Tons.

$$(a) Q_{n,1} (kW) = \frac{4}{\text{New Recirculation Rate (n)}} \times Q_{4,1} (\text{Tons})$$

$$Q_{3,1} (kW) = \frac{4}{3} \times 14 \text{ Tons}$$

$$Q_{3,1} = 19 \text{ Tons}$$

HEVs

Liquid Overfeed Capacities - Angle Body

R-22 (KW)

Port Size	Pressure Drop (bar)	Number of Turns													
		1	2	3	4	5	6	7	8	9	10	11	12	13	14
6mm	0.34	5.1	10	13	15	17									
	0.69	7.2	14	18	22	24									
	1.03	8.9	17	22	27	30	—	—	—	—	—	—	—	—	—
	1.38	10	20	26	31	34									
	2.07	13	25	32	38	42									
10mm	0.34	5.4	12	16	20	25									
	0.69	7.6	17	23	29	35									
	1.03	9.3	21	29	35	43	—	—	—	—	—	—	—	—	—
	1.38	11	24	33	40	50									
	2.07	13	30	40	49	61									
13mm	0.34	3.9	11	16	20	24									
	0.69	5.5	15	22	29	34									
	1.03	6.7	18	27	35	42	—	—	—	—	—	—	—	—	—
	1.38	7.7	21	32	40	49									
	2.07	9.5	26	39	49	60									
20mm	0.34	2.4	4.7	14	22	29	35								
	0.69	3.4	6.7	19	31	41	49								
	1.03	4.2	8.1	24	38	50	61	—	—	—	—	—	—	—	—
	1.38	4.9	9.4	27	44	58	70								
	2.07	6.0	12	34	53	71	86								
25mm	0.34	2.4	4.5	6.6	21	29	34								
	0.69	3.4	6.4	9.3	30	41	48								
	1.03	4.2	7.9	11	36	51	58	—	—	—	—	—	—	—	—
	1.38	4.9	9.1	13	42	58	67								
	2.07	6.0	11	16	51	72	82								
32mm	0.34	5.8	28	79	121	133	147	149	155	169					
	0.69	8.2	39	112	171	188	208	210	219	238					
	1.03	10	48	137	210	230	254	258	269	292	—	—	—	—	—
	1.38	12	56	158	242	265	294	298	310	337					
	2.07	14	68	193	297	325	360	365	380	413					
40mm	0.34	2.6	3.9	48	94	119	136	145	153	157					
	0.69	3.7	5.6	68	132	169	192	205	217	222					
	1.03	4.5	6.8	83	162	207	235	251	265	272	—	—	—	—	—
	1.38	5.2	7.9	96	187	239	272	290	306	314					
	2.07	6.4	9.7	118	229	293	333	355	375	384					
50mm	0.34	93	96	142	155	172	190	213	230	256	276	288	303	307	325
	0.69	132	136	201	219	243	269	301	326	362	390	407	428	435	459
	1.03	161	166	246	268	297	329	369	399	443	478	498	524	533	562
	1.38	186	192	284	310	343	380	426	461	512	552	575	605	615	649
	2.07	228	235	348	379	421	466	521	564	627	676	704	741	753	795

Capacities for R22 are based on -5°C liquid and -5°C evaporator temperature. For other evaporator temperatures, these values will change only slightly due to density and latent heat variations.

A recirculation rate of 4:1 was used to calculate the capacity tables. For other recirculation rates, divide 4 by the new recirculation rate and multiply values shown in table to arrive at new capacity.

Example: Calculate the capacity of 25mm port hand expansion valve at three turns with recirculation rate of 3:1 and a pressure drop of 1.03 bars.

Known: The capacity of a 25mm port hand expansion valve at three turns with a recirculation rate of 4:1 and a pressure drop of 1.03 bars is 11 kW.

$$(a) Q_{n:1} \text{ (kW)} = \frac{4}{\text{New Recirculation Rate (n)}} \times Q_{4:1} \text{ (kW)}$$

$$Q_{3:1} \text{ (kW)} = \frac{4}{3} \times 11 \text{ kW}$$

$$Q_{3:1} = 15 \text{ kW}$$

Liquid Overfeed Capacities - Angle Body

R-22 (TONS)

Port Size	Pressure Drop (psi)	Number of Turns													
		1	2	3	4	5	6	7	8	9	10	11	12	13	14
1/4"	5	1.5	2.9	3.7	4.4	4.9									
	10	2.1	4.1	5.2	6.3	6.9									
	15	2.5	5.0	6.4	7.7	8.5	-	-	-	-	-	-	-	-	-
	20	2.9	5.8	7.4	8.9	9.8									
	30	3.6	7.1	9.1	11	12									
3/8"	5	1.5	3.5	4.7	5.8	7.1									
	10	2.2	4.9	6.7	8.2	10									
	15	2.7	6.0	8.2	10	12	-	-	-	-	-	-	-	-	-
	20	3.1	6.9	9.4	12	14									
	30	3.8	8.5	12	14	17									
1/2"	5	1.1	3.1	4.6	5.8	7.0									
	10	1.6	4.3	6.4	8.2	9.9									
	15	1.9	5.3	7.9	10	12	-	-	-	-	-	-	-	-	-
	20	2.2	6.1	9	12	14									
	30	2.7	7.5	11	14	17									
3/4"	5	0.7	1.3	3.9	6.3	8.4	10								
	10	1.0	1.9	5.6	8.9	12	14								
	15	1.2	2.3	6.8	11	14	17	-	-	-	-	-	-	-	-
	20	1.4	2.7	7.8	13	17	20								
	30	1.7	3.3	9.6	15	20	25								
1"	5	0.7	1.3	1.9	6.0	8.4	9.6								
	10	1.0	1.8	2.7	8.5	12	14								
	15	1.2	2.3	3.3	10	15	17	-	-	-	-	-	-	-	-
	20	1.4	2.6	3.8	12	17	19								
	30	1.7	3.2	4.6	15	21	24								
1 1/4"	5	1.7	8.0	23	35	38	42	43	44	48					
	10	2.3	11	32	49	54	60	60	63	68					
	15	2.9	14	39	60	66	73	74	77	84	-	-	-	-	-
	20	3.3	16	45	69	76	84	85	89	97					
	30	4.1	20	55	85	93	103	105	109	118					
1 1/2"	5	0.7	1.1	14	27	34	39	42	44	45					
	10	1.1	1.6	19	38	48	55	59	62	64					
	15	1.3	2.0	24	46	59	67	72	76	78	-	-	-	-	-
	20	1.5	2.3	28	54	68	78	83	88	90					
	30	1.8	2.8	34	66	84	95	102	108	110					
2"	5	27	28	41	44	49	55	61	66	73	79	82	87	88	93
	10	38	39	58	63	70	77	86	93	104	112	117	123	125	132
	15	46	48	70	77	85	94	106	114	127	137	143	150	153	161
	20	53	55	81	89	98	109	122	132	147	158	165	174	176	186
	30	65	67	100	109	121	134	150	162	180	194	202	213	216	228

Capacities for R22 are based on 20°F liquid and 20°F evaporator temperature. For other evaporator temperatures, these values will change only slightly due to density and latent heat variations.

A recirculation rate of 4:1 was used to calculate the capacity tables. For other recirculation rates, divide 4 by the new recirculation rate and multiply values shown in table to arrive at new capacity.

Example: Calculate the capacity of 1" port hand expansion valve at three turns with recirculation rate of 3:1 and a pressure drop of 15 psi.

Known: The capacity of a 1" port hand expansion valve at three turns with a recirculation rate of 4:1 and a pressure drop of 15 psi is 3.3 Tons.

$$(a) Q_{n:1} \text{ (kW)} = \frac{4}{\text{New Recirculation Rate (n)}} \times Q_{4:1} \text{ (Tons)}$$

$$Q_{3:1} \text{ (kW)} = \frac{4}{3} \times 3.3 \text{ Tons}$$

$$Q_{3:1} = 4.4 \text{ Tons}$$

HEVs

Liquid Overfeed Capacities - Angle Body

R-134a (KW)

Port Size	Pressure Drop (bar)	Number of Turns													
		1	2	3	4	5	6	7	8	9	10	11	12	13	14
6mm	0.34	5.0	9.8	13	15	17									
	0.69	7.0	14	18	21	23									
	1.03	8.6	17	22	26	29	—	—	—	—	—	—	—	—	—
	1.38	10	20	25	30	33									
	2.07	12	24	31	37	41									
10mm	0.34	5.2	12	16	20	24									
	0.69	7.4	17	23	28	34									
	1.03	9.1	20	28	34	42	—	—	—	—	—	—	—	—	—
	1.38	10	24	32	39	48									
	2.07	13	29	39	48	59									
13mm	0.34	3.8	10	15	20	24									
	0.69	5.3	15	22	28	34									
	1.03	6.5	18	27	34	41	—	—	—	—	—	—	—	—	—
	1.38	7.5	21	31	39	47									
	2.07	9.2	25	38	48	58									
20mm	0.34	2.4	4.6	13	21	28	34								
	0.69	3.4	6.5	19	30	40	48								
	1.03	4.1	7.9	23	37	49	59	—	—	—	—	—	—	—	—
	1.38	4.7	9.2	27	42	57	68								
	2.07	5.8	11	33	52	69	83								
25mm	0.34	2.4	4.4	6.4	20	28	33								
	0.69	3.4	6.2	9.0	29	40	46								
	1.03	4.1	7.6	11	35	49	57	—	—	—	—	—	—	—	—
	1.38	4.7	8.8	13	41	57	65								
	2.07	5.8	11	16	50	70	80								
32mm	0.34	5.6	27	77	118	129	143	145	151	164					
	0.69	8.0	38	109	167	183	202	205	213	232					
	1.03	9.8	47	133	204	224	247	251	261	284	—	—	—	—	—
	1.38	11	54	154	236	258	286	290	302	328					
	2.07	14	66	188	289	316	350	355	369	402					
40mm	0.34	2.5	3.8	47	91	116	132	141	149	153					
	0.69	3.6	5.4	66	129	164	187	200	211	216					
	1.03	4.4	6.7	81	158	201	229	245	258	265	—	—	—	—	—
	1.38	5.1	7.7	93	182	232	264	282	298	305					
	2.07	6.2	9.4	114	223	285	324	346	365	374					
50mm	0.34	91	93	138	151	167	185	207	224	249	268	280	294	299	316
	0.69	128	132	195	213	236	262	293	317	352	380	396	416	423	447
	1.03	157	162	239	261	289	321	359	388	431	465	485	510	518	547
	1.38	181	187	276	301	334	370	414	448	498	537	560	589	598	632
	2.07	222	229	338	369	409	453	507	549	610	658	685	721	733	774

Capacities for R134a are based on -5°C liquid and -5°C evaporator temperature. For other evaporator temperatures, these values will change only slightly due to density and latent heat variations.

A recirculation rate of 4:1 was used to calculate the capacity tables. For other recirculation rates, divide 4 by the new recirculation rate and multiply values shown in table to arrive at new capacity.

Example: Calculate the capacity of 25mm port hand expansion valve at three turns with recirculation rate of 3:1 and a pressure drop of 1.03 bars.

Known: The capacity of a 25mm port hand expansion valve at three turns with a recirculation rate of 4:1 and a pressure drop of 1.03 bars is 11 kW.

$$(a) Q_{n:1} \text{ (kW)} = \frac{4}{\text{New Recirculation Rate (n)}} \times Q_{4:1} \text{ (kW)}$$

$$Q_{3:1} \text{ (kW)} = \frac{4}{3} \times 11 \text{ kW}$$

$$Q_{3:1} = 15 \text{ kW}$$

Liquid Overfeed Capacities - Angle Body

R-134a (TONS)

Port Size	Pressure Drop (psi)	Number of Turns													
		1	2	3	4	5	6	7	8	9	10	11	12	13	14
1/4"	5	1.4	2.8	3.6	4.3	4.8									
	10	2.0	4.0	5.1	6.1	6.7									
	15	2.5	4.9	6.2	7.5	8.2	-	-	-	-	-	-	-	-	-
	20	2.9	5.6	7.2	8.6	9.5									
	30	3.5	6.9	8.8	11	12									
3/8"	5	1.5	3.4	4.6	5.6	6.9									
	10	2.1	4.8	6.5	7.9	9.8									
	15	2.6	5.8	8.0	9.7	12	-	-	-	-	-	-	-	-	-
	20	3.0	6.7	9.2	11	14									
	30	3.7	8.3	11	14	17									
1/2"	5	1.1	3.0	4.4	5.6	6.8									
	10	1.5	4.2	6.3	7.9	9.6									
	15	1.9	5.2	7.7	9.7	12	-	-	-	-	-	-	-	-	-
	20	2.2	5.9	8.9	11	14									
	30	2.6	7.3	11	14	17									
3/4"	5	0.7	1.3	3.8	6.1	8.1	9.7								
	10	1.0	1.9	5.4	8.6	11	14								
	15	1.2	2.3	6.6	11	14	17	-	-	-	-	-	-	-	-
	20	1.4	2.6	7.6	12	16	19								
	30	1.7	3.2	9.4	15	20	24								
1"	5	0.7	1.3	1.8	5.9	8.2	9.4								
	10	1.0	1.8	2.6	8.3	12	13								
	15	1.2	2.2	3.2	10	14	16	-	-	-	-	-	-	-	-
	20	1.4	2.5	3.7	12	16	19								
	30	1.7	3.1	4.5	14	20	23								
1 1/4"	5	1.6	7.8	22	34	37	41	42	43	47					
	10	2.3	11	31	48	52	58	59	61	67					
	15	2.8	13	38	58	64	71	72	75	81	-	-	-	-	-
	20	3.2	16	44	68	74	82	83	86	94					
	30	4.0	19	54	83	91	100	102	106	115					
1 1/2"	5	0.7	1.1	13	26	33	38	40	43	44					
	10	1.0	1.6	19	37	47	54	57	60	62					
	15	1.3	1.9	23	45	58	66	70	74	76	-	-	-	-	-
	20	1.5	2.2	27	52	67	76	81	85	88					
	30	1.8	2.7	33	64	82	93	99	105	107					
2"	5	26	27	40	43	48	53	59	64	71	77	80	84	86	91
	10	37	38	56	61	68	75	84	91	101	109	113	119	121	128
	15	45	46	69	75	83	92	103	111	124	133	139	146	149	157
	20	52	54	79	86	96	106	119	128	143	154	160	169	171	181
	30	64	66	97	106	117	130	145	157	175	189	196	207	210	222

Capacities for R134a are based on 20°F liquid and 20°F evaporator temperature. For other evaporator temperatures, these values will change only slightly due to density and latent heat variations.

A recirculation rate of 4:1 was used to calculate the capacity tables. For other recirculation rates, divide 4 by the new recirculation rate and multiply values shown in table to arrive at new capacity.

Example: Calculate the capacity of 1" port hand expansion valve at three turns with recirculation rate of 3:1 and a pressure drop of 15 psi.

Known: The capacity of a 1" port hand expansion valve at three turns with a recirculation rate of 4:1 and a pressure drop of 15 psi is 3.2 Tons.

$$(a) Q_{n:1} \text{ (kW)} = \frac{4}{\text{New Recirculation Rate (n)}} \times Q_{4:1} \text{ (Tons)}$$

$$Q_{3:1} \text{ (kW)} = \frac{4}{3} \times 3.2 \text{ Tons}$$

$$Q_{3:1} = 4.3 \text{ Tons}$$

HEVs

Liquid Overfeed Capacities - Angle Body

R-404a (KW)

Port Size	Pressure Drop (bar)	Number of Turns													
		1	2	3	4	5	6	7	8	9	10	11	12	13	14
6mm	0.34	4.0	7.8	10	12	13									
	0.69	5.6	11	14	17	19									
	1.03	6.9	13	17	21	23	—	—	—	—	—	—	—	—	—
	1.38	7.9	16	20	24	26									
	2.07	9.7	19	24	29	32									
10mm	0.34	4.2	9.3	13	16	19									
	0.69	5.9	13	18	22	27									
	1.03	7.2	16	22	27	33	—	—	—	—	—	—	—	—	—
	1.38	8.3	19	25	31	38									
	2.07	10	23	31	38	47									
13mm	0.34	3.0	8.2	12	16	19									
	0.69	4.2	12	17	22	27									
	1.03	5.2	14	21	27	33	—	—	—	—	—	—	—	—	—
	1.38	6.0	16	25	31	38									
	2.07	7.3	20	30	38	46									
20mm	0.34	1.9	3.6	11	17	23	27								
	0.69	2.7	5.1	15	24	32	38								
	1.03	3.3	6.3	18	29	39	47	—	—	—	—	—	—	—	—
	1.38	3.8	7.3	21	34	45	54								
	2.07	4.6	8.9	26	41	55	66								
25mm	0.34	1.9	3.5	5.1	16	23	26								
	0.69	2.7	5.0	7.2	23	32	37								
	1.03	3.3	6.1	8.8	28	39	45	—	—	—	—	—	—	—	—
	1.38	3.8	7.0	10	32	45	52								
	2.07	4.6	8.6	12	40	55	64								
32mm	0.34	4.5	22	61	94	103	113	115	120	130					
	0.69	6.3	30	86	132	145	160	163	169	184					
	1.03	7.8	37	106	162	178	196	199	207	226	—	—	—	—	—
	1.38	9.0	43	122	187	205	227	230	240	261					
	2.07	11.0	53	149	229	251	278	282	293	319					
40mm	0.34	2.0	3.0	37	72	92	105	112	118	121					
	0.69	2.8	4.3	52	102	130	148	159	167	171					
	1.03	3.5	5.3	64	125	160	182	194	205	210	—	—	—	—	—
	1.38	4.0	6.1	74	145	185	210	224	237	243					
	2.07	4.9	7.5	91	177	226	257	275	290	297					
50mm	0.34	72	74	110	120	133	147	164	178	198	213	222	234	238	251
	0.69	102	105	155	169	188	208	233	252	280	302	314	331	336	355
	1.03	125	129	190	207	230	255	285	308	342	369	385	405	411	434
	1.38	144	148	219	239	265	294	329	356	395	426	444	468	475	502
	2.07	176	182	269	293	325	360	403	436	484	522	544	573	582	614

Capacities for R404a are based on -5°C liquid and -5°C evaporator temperature. For other evaporator temperatures, these values will change only slightly due to density and latent heat variations.

A recirculation rate of 4:1 was used to calculate the capacity tables. For other recirculation rates, divide 4 by the new recirculation rate and multiply values shown in table to arrive at new capacity.

Example: Calculate the capacity of 25mm port hand expansion valve at three turns with recirculation rate of 3:1 and a pressure drop of 1.03 bars.

Known: The capacity of a 25mm port hand expansion valve at three turns with a recirculation rate of 4:1 and a pressure drop of 1.03 bars is 8.8 kW.

$$(a) Q_{n:1} \text{ (kW)} = \frac{4}{\text{New Recirculation Rate (n)}} \times Q_{4:1} \text{ (kW)}$$

$$Q_{3:1} \text{ (kW)} = \frac{4}{3} \times 8.8 \text{ kW}$$

$$Q_{3:1} = 12 \text{ kW}$$

Liquid Overfeed Capacities - Angle Body

R-404a (TONS)

Port Size	Pressure Drop (psi)	Number of Turns													
		1	2	3	4	5	6	7	8	9	10	11	12	13	14
1/4"	5	1.1	2.2	2.9	3.4	3.8									
	10	1.6	3.2	4.1	4.9	5.4									
	15	2.0	3.9	5.0	5.9	6.6	-	-	-	-	-	-	-	-	-
	20	2.3	4.5	5.7	6.9	7.6									
	30	2.8	5.5	7.0	8.4	9.3									
3/8"	5	1.2	2.7	3.7	4.5	5.5									
	10	1.7	3.8	5.2	6.3	7.8									
	15	2.1	4.7	6.3	7.8	9.6	-	-	-	-	-	-	-	-	-
	20	2.4	5.4	7.3	9.0	11									
	30	2.9	6.6	9.0	11	14									
1/2"	5	0.9	2.4	3.5	4.5	5.4									
	10	1.2	3.3	5.0	6.3	7.6									
	15	1.5	4.1	6.1	7.8	9.4	-	-	-	-	-	-	-	-	-
	20	1.7	4.7	7.1	9.0	11									
	30	2.1	5.8	8.6	11	13									
3/4"	5	0.5	1.0	3.0	4.8	6.5	7.8								
	10	0.8	1.5	4.3	6.9	9.2	11								
	15	0.9	1.8	5.3	8.4	11	13	-	-	-	-	-	-	-	-
	20	1.1	2.1	6.1	9.7	13	16								
	30	1.3	2.6	7.4	12	16	19								
1"	5	0.5	1.0	1.5	4.7	6.5	7.5								
	10	0.8	1.4	2.1	6.6	9.2	11								
	15	0.9	1.7	2.5	8.1	11	13	-	-	-	-	-	-	-	-
	20	1.1	2.0	2.9	9.3	13	15								
	30	1.3	2.5	3.6	11	16	18								
1 1/4"	5	1.3	6.2	18	27	29	33	33	34	37					
	10	1.8	8.8	25	38	42	46	47	49	53					
	15	2.2	11	30	47	51	56	57	60	65	-	-	-	-	-
	20	2.6	12	35	54	59	65	66	69	75					
	30	3.2	15	43	66	72	80	81	84	92					
1 1/2"	5	0.6	0.9	11	21	27	30	32	34	35					
	10	0.8	1.2	15	29	38	43	46	48	49					
	15	1.0	1.5	18	36	46	52	56	59	60	-	-	-	-	-
	20	1.2	1.8	21	42	53	60	64	68	70					
	30	1.4	2.1	26	51	65	74	79	83	85					
2"	5	21	21	32	34	38	42	47	51	57	61	64	67	68	72
	10	29	30	45	49	54	60	67	72	80	87	90	95	97	102
	15	36	37	55	60	66	73	82	89	98	106	111	116	118	125
	20	41	43	63	69	76	84	95	102	114	123	128	134	137	144
	30	51	52	77	84	93	103	116	125	139	150	156	165	167	177

Capacities for R404a are based on 20°F liquid and 20°F evaporator temperature. For other evaporator temperatures, these values will change only slightly due to density and latent heat variations.

A recirculation rate of 4:1 was used to calculate the capacity tables. For other recirculation rates, divide 4 by the new recirculation rate and multiply values shown in table to arrive at new capacity.

Example: Calculate the capacity of 1" port hand expansion valve at three turns with recirculation rate of 3:1 and a pressure drop of 15 psi.

Known: The capacity of a 1" port hand expansion valve at three turns with a recirculation rate of 4:1 and a pressure drop of 15 psi is 2.5 Tons.

$$(a) Q_{n:1} (kW) = \frac{4}{\text{New Recirculation Rate (n)}} \times Q_{4:1} (\text{Tons})$$

$$Q_{3:1} (kW) = \frac{4}{3} \times 2.5 \text{ Tons}$$

$$Q_{3:1} = 3.3 \text{ Tons}$$

HEVs

Liquid Overfeed Capacities - Angle Body

R-410a (KW)

Port Size	Pressure Drop (bar)	Number of Turns													
		1	2	3	4	5	6	7	8	9	10	11	12	13	14
6mm	0.34	5.3	10	13	16	18									
	0.69	7.5	15	19	23	25									
	1.03	9.2	18	23	28	31	—	—	—	—	—	—	—	—	—
	1.38	11	21	27	32	35									
	2.07	13	26	33	39	43									
10mm	0.34	5.6	13	17	21	26									
	0.69	7.9	18	24	30	37									
	1.03	9.7	22	30	36	45	—	—	—	—	—	—	—	—	—
	1.38	11	25	34	42	52									
	2.07	14	31	42	51	63									
13mm	0.34	4.0	11	17	21	25									
	0.69	5.7	16	23	30	36									
	1.03	7.0	19	29	36	44	—	—	—	—	—	—	—	—	—
	1.38	8.0	22	33	42	51									
	2.07	9.8	27	40	51	62									
20mm	0.34	2.5	4.9	14	23	30	36								
	0.69	3.6	6.9	20	32	43	51								
	1.03	4.4	8.5	25	39	53	63	—	—	—	—	—	—	—	—
	1.38	5.1	9.8	28	45	61	73								
	2.07	6.2	12	35	56	74	89								
25mm	0.34	2.5	4.7	6.8	22	30	35								
	0.69	3.6	6.7	10	31	43	49								
	1.03	4.4	8.2	12	38	53	61	—	—	—	—	—	—	—	—
	1.38	5.1	9.4	14	44	61	70								
	2.07	6.2	12	17	54	75	86								
32mm	0.34	6.0	29	82	126	138	153	155	161	176					
	0.69	8.5	41	116	178	195	216	219	228	248					
	1.03	10	50	142	218	239	265	268	279	304	—	—	—	—	—
	1.38	12	58	164	252	276	306	310	323	351					
	2.07	15	71	201	309	338	374	379	395	430					
40mm	0.34	2.7	4.1	50	97	124	141	151	159	163					
	0.69	3.8	5.8	71	138	176	200	214	225	231					
	1.03	4.7	7.1	87	169	215	245	262	276	283	—	—	—	—	—
	1.38	5.4	8.2	100	195	249	283	302	319	327					
	2.07	6.6	10	122	239	304	346	370	391	400					
50mm	0.34	97	100	148	161	179	198	222	240	266	287	299	315	320	338
	0.69	137	141	209	228	253	280	313	339	377	406	423	446	453	478
	1.03	168	173	256	279	310	343	384	415	461	498	518	546	554	585
	1.38	194	200	295	322	358	396	443	479	533	574	599	630	640	676
	2.07	237	245	362	395	438	485	543	587	652	704	733	772	784	828

Capacities for R410a are based on -5°C liquid and -5°C evaporator temperature. For other evaporator temperatures, these values will change only slightly due to density and latent heat variations.

A recirculation rate of 4:1 was used to calculate the capacity tables. For other recirculation rates, divide 4 by the new recirculation rate and multiply values shown in table to arrive at new capacity.

Example: Calculate the capacity of 25mm port hand expansion valve at three turns with recirculation rate of 3:1 and a pressure drop of 1.03 bars.

Known: The capacity of a 25mm port hand expansion valve at three turns with a recirculation rate of 4:1 and a pressure drop of 1.03 bars is 12 kW.

$$(a) Q_{n:1} \text{ (kW)} = \frac{4}{\text{New Recirculation Rate (n)}} \times Q_{4:1} \text{ (kW)}$$

$$Q_{3:1} \text{ (kW)} = \frac{4}{3} \times 12 \text{ kW}$$

$$Q_{3:1} = 16 \text{ kW}$$

Liquid Overfeed Capacities - Angle Body

R-410a (TONS)

Port Size	Pressure Drop (psi)	Number of Turns													
		1	2	3	4	5	6	7	8	9	10	11	12	13	14
1/4"	5	1.5	3.0	3.9	4.6	5.1									
	10	2.2	4.3	5.5	6.5	7.2									
	15	2.7	5.2	6.7	8.0	8.8	-	-	-	-	-	-	-	-	-
	20	3.1	6.0	7.7	9.2	10									
	30	3.8	7.4	9.5	11	12									
3/8"	5	1.6	3.6	4.9	6.0	7.4									
	10	2.3	5.1	7.0	8.5	11									
	15	2.8	6.3	8.5	10	13	-	-	-	-	-	-	-	-	-
	20	3.2	7.2	9.9	12	15									
	30	3.9	8.9	12	15	18									
1/2"	5	1.2	3.2	4.8	6.0	7.3									
	10	1.6	4.5	6.7	8.5	10									
	15	2.0	5.5	8.2	10	13	-	-	-	-	-	-	-	-	-
	20	2.3	6.4	9.5	12	15									
	30	2.8	7.8	12	15	18									
3/4"	5	0.7	1.4	4.1	6.5	8.7	10								
	10	1.0	2.0	5.8	9.2	12	15								
	15	1.3	2.4	7.1	11	15	18	-	-	-	-	-	-	-	-
	20	1.5	2.8	8.2	13	17	21								
	30	1.8	3.4	10	16	21	26								
1"	5	0.7	1.4	2.0	6.3	8.7	10								
	10	1.0	1.9	2.8	8.9	12	14								
	15	1.3	2.4	3.4	11	15	17	-	-	-	-	-	-	-	-
	20	1.5	2.7	3.9	13	17	20								
	30	1.8	3.3	4.8	15	21	25								
1 1/4"	5	1.7	8.3	24	36	40	44	45	46	50	51				
	10	2.5	12	33	51	56	62	63	66	71	73				
	15	3.0	14	41	63	69	76	77	80	87	89	-	-	-	-
	20	3.5	17	47	72	79	88	89	93	101	103				
	30	4.2	20	58	89	97	108	109	114	124	126				
1 1/2"	5	0.8	1.2	14	28	36	41	43	46	47	48				
	10	1.1	1.7	20	40	51	58	61	65	66	67				
	15	1.3	2.0	25	48	62	70	75	79	81	83	-	-	-	-
	20	1.6	2.4	29	56	71	81	87	92	94	95				
	30	1.9	2.9	35	69	88	100	106	112	115	117				
2"	5	28	29	42	46	51	57	64	69	77	83	86	91	92	97
	10	39	41	60	66	73	81	90	97	108	117	122	128	130	137
	15	48	50	74	80	89	99	110	119	133	143	149	157	159	168
	20	56	58	85	93	103	114	127	138	153	165	172	181	184	194
	30	68	70	104	114	126	139	156	169	188	202	211	222	225	238

Capacities for R410a are based on 20°F liquid and 20°F evaporator temperature. For other evaporator temperatures, these values will change only slightly due to density and latent heat variations.

A recirculation rate of 4:1 was used to calculate the capacity tables. For other recirculation rates, divide 4 by the new recirculation rate and multiply values shown in table to arrive at new capacity.

Example: Calculate the capacity of 1" port hand expansion valve at three turns with recirculation rate of 3:1 and a pressure drop of 15 psi.

Known: The capacity of a 1" port hand expansion valve at three turns with a recirculation rate of 4:1 and a pressure drop of 15 psi is 3.4 Tons.

$$(a) Q_{n:1} \text{ (kW)} = \frac{4}{\text{New Recirculation Rate (n)}} \times Q_{4:1} \text{ (Tons)}$$

$$Q_{3:1} \text{ (kW)} = \frac{4}{3} \times 3.4 \text{ Tons}$$

$$Q_{3:1} = 4.5 \text{ Tons}$$

HEVs

Liquid Overfeed Capacities - Angle Body

R-507a (KW)

Port Size	Pressure Drop (bar)	Number of Turns													
		1	2	3	4	5	6	7	8	9	10	11	12	13	14
6mm	0.34	3.9	7.6	9.8	11.7	12.9									
	0.69	5.5	10.8	14	17	18									
	1.03	6.7	13	17	20	22	—	—	—	—	—	—	—	—	—
	1.38	7.8	15	20	23	26									
	2.07	9.5	19	24	29	32									
10mm	0.34	4.1	9.2	12	15	19									
	0.69	5.8	13	18	22	27									
	1.03	7.1	16	22	26	33	—	—	—	—	—	—	—	—	—
	1.38	8.1	18	25	31	38									
	2.07	10	22	31	37	46									
13mm	0.34	2.9	8.1	12	15	18									
	0.69	4.1	11	17	22	26									
	1.03	5.1	14	21	26	32	—	—	—	—	—	—	—	—	—
	1.38	5.9	16	24	31	37									
	2.07	7.2	20	29	37	45									
20mm	0.34	1.8	3.6	10	17	22	26								
	0.69	2.6	5.0	15	23	31	37								
	1.03	3.2	6.2	18	29	38	46	—	—	—	—	—	—	—	—
	1.38	3.7	7.1	21	33	44	53								
	2.07	4.5	8.7	25	41	54	65								
25mm	0.34	1.8	3.4	5.0	16	22	25								
	0.69	2.6	4.9	7.0	22	31	36								
	1.03	3.2	6.0	8.6	28	38	44	—	—	—	—	—	—	—	—
	1.38	3.7	6.9	9.9	32	44	51								
	2.07	4.5	8.4	12	39	54	62								
32mm	0.34	4.4	21	60	92	101	111	113	117	128					
	0.69	6.2	30	85	130	142	157	159	166	181					
	1.03	7.6	37	104	159	174	193	195	203	221	—	—	—	—	—
	1.38	8.8	42	120	184	201	222	226	235	256					
	2.07	11	52	147	225	246	272	276	288	313					
40mm	0.34	2.0	3.0	36	71	90	103	110	116	119					
	0.69	2.8	4.2	51	100	128	146	156	164	168					
	1.03	3.4	5.2	63	123	157	178	190	201	206	—	—	—	—	—
	1.38	3.9	6.0	73	142	181	206	220	232	238					
	2.07	4.8	7.3	89	174	222	252	269	284	291					
50mm	0.34	71	73	108	117	130	144	161	174	194	209	218	229	233	246
	0.69	100	103	152	166	184	204	228	247	274	296	308	324	329	348
	1.03	122	126	186	203	225	250	279	302	336	362	377	397	403	426
	1.38	141	146	215	235	260	288	323	349	388	418	436	459	466	492
	2.07	173	178	263	287	319	353	395	427	475	512	534	562	571	602

Capacities for R507a are based on -5°C liquid and -5°C evaporator temperature. For other evaporator temperatures, these values will change only slightly due to density and latent heat variations.

A recirculation rate of 4:1 was used to calculate the capacity tables. For other recirculation rates, divide 4 by the new recirculation rate and multiply values shown in table to arrive at new capacity.

Example: Calculate the capacity of 25mm port hand expansion valve at three turns with recirculation rate of 3:1 and a pressure drop of 1.03 bars.

Known: The capacity of a 25mm port hand expansion valve at three turns with a recirculation rate of 4:1 and a pressure drop of 1.03 bars is 8.6 kW.

$$(a) Q_{n:1} \text{ (kW)} = \frac{4}{\text{New Recirculation Rate (n)}} \times Q_{4:1} \text{ (kW)}$$

$$Q_{3:1} \text{ (kW)} = \frac{4}{3} \times 8.6 \text{ kW}$$

$$Q_{3:1} = 12 \text{ kW}$$

Liquid Overfeed Capacities - Angle Body

R-507a (TONS)

Port Size	Pressure Drop (psi)	Number of Turns													
		1	2	3	4	5	6	7	8	9	10	11	12	13	14
1/4"	5	1.1	2.2	2.8	3.4	3.7									
	10	1.6	3.1	4.0	4.8	5.3									
	15	1.9	3.8	4.9	5.8	6.4	-	-	-	-	-	-	-	-	-
	20	2.2	4.4	5.6	6.7	7.4									
	30	2.7	5.4	6.9	8.2	9.1									
3/8"	5	1.2	2.6	3.6	4.4	5.4									
	10	1.7	3.7	5.1	6.2	7.7									
	15	2.0	4.6	6.2	7.6	9.4	-	-	-	-	-	-	-	-	-
	20	2.3	5.3	7.2	8.8	11									
	30	2.9	6.5	8.8	11	13									
1/2"	5	0.8	2.3	3.5	4.4	5.3									
	10	1.2	3.3	4.9	6.2	7.5									
	15	1.5	4.0	6.0	7.6	9.2	-	-	-	-	-	-	-	-	-
	20	1.7	4.6	6.9	8.8	11									
	30	2.1	5.7	8.5	11	13									
3/4"	5	0.5	1.0	3.0	4.8	6.3	7.6								
	10	0.8	1.4	4.2	6.7	9.0	11								
	15	0.9	1.8	5.2	8.2	11	13	-	-	-	-	-	-	-	-
	20	1.1	2.0	6.0	9.5	13	15								
	30	1.3	2.5	7.3	12	16	19								
1"	5	0.5	1.0	1.4	4.6	6.4	7.3								
	10	0.8	1.4	2.0	6.5	9.0	10								
	15	0.9	1.7	2.5	7.9	11	13	-	-	-	-	-	-	-	-
	20	1.1	2.0	2.9	9.1	13	15								
	30	1.3	2.4	3.5	11	16	18								
1 1/4"	5	1.3	6.1	17	26	29	32	32	34	37					
	10	1.8	8.6	24	37	41	45	46	48	52					
	15	2.2	11	30	46	50	55	56	58	64	-	-	-	-	-
	20	2.5	12	34	53	58	64	65	68	73					
	30	3.1	15	42	65	71	78	79	83	90					
1 1/2"	5	0.6	0.9	10	20	26	30	32	33	34					
	10	0.8	1.2	15	29	37	42	45	47	48					
	15	1.0	1.5	18	35	45	51	55	58	59	-	-	-	-	-
	20	1.1	1.7	21	41	52	59	63	67	68					
	30	1.4	2.1	26	50	64	73	77	82	84					
2"	5	20	21	31	34	37	41	46	50	56	60	63	66	67	71
	10	29	30	44	48	53	59	66	71	79	85	89	93	95	100
	15	35	36	54	58	65	72	80	87	97	104	109	114	116	122
	20	41	42	62	67	75	83	93	100	111	120	125	132	134	141
	30	50	51	76	83	92	102	114	123	137	147	153	162	164	173

Capacities for R507a are based on 20°F liquid and 20°F evaporator temperature. For other evaporator temperatures, these values will change only slightly due to density and latent heat variations.

A recirculation rate of 4:1 was used to calculate the capacity tables. For other recirculation rates, divide 4 by the new recirculation rate and multiply values shown in table to arrive at new capacity.

Example: Calculate the capacity of 1" port hand expansion valve at three turns with recirculation rate of 3:1 and a pressure drop of 15 psi.

Known: The capacity of a 1" port hand expansion valve at three turns with a recirculation rate of 4:1 and a pressure drop of 15 psi is 2.5 Tons.

$$(a) Q_{n:1} (kW) = \frac{4}{\text{New Recirculation Rate (n)}} \times Q_{4:1} (\text{Tons})$$

$$Q_{3:1} (kW) = \frac{4}{3} \times 2.5 \text{ Tons}$$

$$Q_{3:1} = 3.3 \text{ Tons}$$

HEVs

Liquid Overfeed Capacities - Globe "Y" Body

R-717 (KW)

Port Size	Pressure Drop (bar)	Number of Turns														
		1	2	3	4	5	6	7	8	9	10	11	12	13	14	15
32mm	0.34	18	93	325	524	562	603	636	673	726						
	0.69	26	131	460	740	795	852	899	951	1027						
	1.03	31	161	563	907	973	1044	1101	1165	1257	—	—	—	—	—	—
	1.38	36	186	650	1047	1124	1205	1271	1345	1452						
	2.07	44	227	797	1282	1377	1476	1557	1647	1778						
40mm	0.34	11	22	233	431	528	585	624	658	689						
	0.69	16	31	329	610	747	828	882	931	974						
	1.03	19	38	403	747	914	1014	1081	1140	1193	—	—	—	—	—	—
	1.38	22	44	466	862	1056	1170	1248	1317	1377						
	2.07	28	53	570	1056	1293	1433	1528	1613	1687						
50mm	0.34	375	396	597	664	707	796	925	976	1107	1205	1225	1279	1361	1386	1485
	0.69	530	559	844	939	999	1126	1309	1380	1566	1704	1733	1808	1925	1961	2101
	1.03	649	685	1034	1150	1224	1379	1603	1691	1918	2087	2122	2215	2358	2401	2573
	1.38	749	791	1194	1328	1413	1592	1851	1952	2215	2410	2450	2558	2723	2773	2971
	2.07	917	969	1462	1627	1731	1950	2266	2391	2712	2951	3001	3132	3335	3396	3639

R-717 (TONS)

Port Size	Pressure Drop (psi)	Number of Turns														
		1	2	3	4	5	6	7	8	9	10	11	12	13	14	15
1¼"	5	5.2	27	93	150	161	172	182	192	208						
	10	7.3	38	132	212	227	244	257	272	294						
	15	9.0	46	161	259	278	299	315	333	360	—	—	—	—	—	—
	20	10	53	186	300	322	345	364	385	415						
	30	13	65	228	367	394	422	445	471	509						
1½"	5	3.2	6.2	67	123	151	167	179	188	197						
	10	4.5	8.8	94	174	214	237	252	266	279						
	15	5.6	11	115	214	262	290	309	326	341	—	—	—	—	—	—
	20	6.4	12	133	247	302	335	357	377	394						
	30	7.9	15	163	302	370	410	437	461	483						
2"	5	107	113	171	190	202	228	265	279	317	345	351	366	390	397	425
	10	152	160	241	269	286	322	374	395	448	487	496	517	551	561	601
	15	186	196	296	329	350	395	459	484	549	597	607	634	675	687	736
	20	214	226	341	380	404	456	529	559	634	689	701	732	779	793	850
	30	262	277	418	466	495	558	648	684	776	844	859	896	954	972	1041

Capacities for R717 are based on -5°C (20°F) liquid and -5°C (20°F) evaporator temperature. For other evaporator temperatures, these values will change only slightly due to density and latent heat variations.

A recirculation rate of 4:1 was used to calculate the capacity tables. For other recirculation rates, divide 4 by the new recirculation rate and multiply values shown in table to arrive at new capacity.

Example: Calculate the capacity of 40mm (1½") port hand expansion valve at three turns with recirculation rate of 3:1 and a pressure drop of 1.03 bars (15 psi).

Known: The capacity of a 40mm (1½") port hand expansion valve at three turns with a recirculation rate of 4:1 and a pressure drop of 1.03 bars (15 psi) is 403 kW (115 Tons).

$$(a) Q_{n:1} (\text{kW}) = \frac{4}{\text{New Recirculation Rate (n)}} \times Q_{4:1} (\text{kW})$$

$$Q_{3:1} (\text{kW}) = \frac{4}{3} \times 403 \text{ kW}$$

$$Q_{3:1} = 537 \text{ kW}$$

$$(b) Q_{n:1} (\text{Tons}) = \frac{4}{\text{New Recirculation Rate (n)}} \times Q_{4:1} (\text{Tons})$$

$$Q_{3:1} (\text{Tons}) = \frac{4}{3} \times 115 \text{ Tons}$$

$$Q_{3:1} = 153 \text{ Tons}$$

Liquid Overfeed Capacities - Globe "Y" Body

R-22 (KW)

Port Size	Pressure Drop (bar)	Number of Turns														
		1	2	3	4	5	6	7	8	9	10	11	12	13	14	15
32mm	0.34	4.2	21	75	121	130	140	147	156	168						
	0.69	5.9	30	107	171	184	197	208	220	238						
	1.03	7.3	37	130	210	225	242	255	270	291	-	-	-	-	-	-
	1.38	8.4	43	151	243	260	279	294	312	336						
	2.07	10	53	185	297	319	342	361	382	412						
40mm	0.34	2.6	5.0	54	100	122	136	145	153	159						
	0.69	3.7	7.1	76	141	173	192	204	216	226						
	1.03	4.5	8.7	93	173	212	235	250	264	276	-	-	-	-	-	-
	1.38	5.2	10	108	200	245	271	289	305	319						
	2.07	6.4	12	132	245	300	332	354	374	391						
50mm	0.34	87	92	138	154	164	184	214	226	256	279	284	296	315	321	344
	0.69	123	130	195	218	231	261	303	320	363	395	401	419	446	454	487
	1.03	150	159	239	266	284	319	371	392	444	483	492	513	546	556	596
	1.38	174	183	276	308	327	369	429	452	513	558	568	592	631	642	688
	2.07	212	224	339	377	401	452	525	554	628	684	695	726	772	787	843

R-22 (TONS)

Port Size	Pressure Drop (psi)	Number of Turns														
		1	2	3	4	5	6	7	8	9	10	11	12	13	14	15
1¼"	5	1.2	6.2	22	35	37	40	42	45	48						
	10	1.7	8.7	31	49	53	57	60	63	68						
	15	2.1	11	37	60	65	69	73	77	83	-	-	-	-	-	-
	20	2.4	12	43	70	75	80	84	89	96						
	30	2.9	15	53	85	91	98	103	109	118						
1½"	5	0.7	1.4	15	29	35	39	41	44	46						
	10	1.1	2.0	22	40	50	55	59	62	65						
	15	1.3	2.5	27	50	61	67	72	76	79	-	-	-	-	-	-
	20	1.5	2.9	31	57	70	78	83	87	91						
	30	1.8	3.5	38	70	86	95	102	107	112						
2"	5	25	26	40	44	47	53	61	65	74	80	81	85	90	92	99
	10	35	37	56	62	66	75	87	92	104	113	115	120	128	130	140
	15	43	45	69	76	81	92	106	112	127	139	141	147	157	159	171
	20	50	53	79	88	94	106	123	130	147	160	163	170	181	184	197
	30	61	64	97	108	115	130	151	159	180	196	199	208	221	226	242

Capacities for R22 are based on -5°C (20°F) liquid and -5°C (20°F) evaporator temperature. For other evaporator temperatures, these values will change only slightly due to density and latent heat variations.

A recirculation rate of 4:1 was used to calculate the capacity tables. For other recirculation rates, divide 4 by the new recirculation rate and multiply values shown in table to arrive at new capacity.

Example: Calculate the capacity of 40mm (1½") port hand expansion valve at three turns with recirculation rate of 3:1 and a pressure drop of 1.03 bars (15 psi).

Known: The capacity of a 40mm (1½") port hand expansion valve at three turns with a recirculation rate of 4:1 and a pressure drop of 1.03 bars (15 psi) is 93 kW (27 Tons).

$$(a) Q_{n:1} \text{ (kW)} = \frac{4}{\text{New Recirculation Rate (n)}} \times Q_{4:1} \text{ (kW)}$$

$$(b) Q_{n:1} \text{ (Tons)} = \frac{4}{\text{New Recirculation Rate (n)}} \times Q_{4:1} \text{ (Tons)}$$

$$Q_{3:1} \text{ (kW)} = \frac{4}{3} \times 93 \text{ kW}$$

$$Q_{3:1} \text{ (Tons)} = \frac{4}{3} \times 27 \text{ Tons}$$

$$Q_{3:1} = 124 \text{ kW}$$

$$Q_{3:1} = 36 \text{ Tons}$$

HEVs

Liquid Overfeed Capacities - Globe "Y" Body

R-134a (KW)

Port Size	Pressure Drop (bar)	Number of Turns														
		1	2	3	4	5	6	7	8	9	10	11	12	13	14	15
32mm	0.34	4.1	21	73	118	127	136	143	152	164						
	0.69	5.8	30	104	167	179	192	203	214	231						
	1.03	7.1	36	127	204	219	235	248	263	283	—	—	—	—	—	—
	1.38	8.2	42	147	236	253	272	286	303	327						
	2.07	10	51	180	289	310	333	351	371	401						
40mm	0.34	2.5	4.9	52	97	119	132	141	148	155						
	0.69	3.6	6.9	74	137	168	187	199	210	219						
	1.03	4.4	8.5	91	168	206	228	244	257	269	—	—	—	—	—	—
	1.38	5.1	9.8	105	194	238	264	281	297	310						
	2.07	6.2	12	128	238	291	323	344	363	380						
50mm	0.34	84	89	134	150	159	179	209	220	250	272	276	288	307	312	335
	0.69	119	126	190	212	225	254	295	311	353	384	390	408	434	442	473
	1.03	146	154	233	259	276	311	361	381	432	470	478	499	531	541	580
	1.38	169	178	269	299	319	359	417	440	499	543	552	576	614	625	670
	2.07	207	218	329	367	390	440	511	539	611	665	676	706	752	765	820

R-134a (TONS)

Port Size	Pressure Drop (psi)	Number of Turns														
		1	2	3	4	5	6	7	8	9	10	11	12	13	14	15
1¼"	5	1.2	6.0	21	34	36	39	41	43	47						
	10	1.7	8.5	30	48	51	55	58	61	66						
	15	2.0	10	36	59	63	67	71	75	81	—	—	—	—	—	—
	20	2.3	12	42	68	73	78	82	87	94						
	30	2.9	15	51	83	89	95	101	106	115						
1½"	5	0.7	1.4	15	28	34	38	40	43	44						
	10	1.0	2.0	21	39	48	53	57	60	63						
	15	1.3	2.4	26	48	59	65	70	74	77	—	—	—	—	—	—
	20	1.5	2.8	30	56	68	76	81	85	89						
	30	1.8	3.4	37	68	84	93	99	104	109						
2"	5	24	26	39	43	46	51	60	63	72	78	79	83	88	90	96
	10	34	36	55	61	65	73	85	89	101	110	112	117	124	127	136
	15	42	44	67	74	79	89	104	109	124	135	137	143	152	155	166
	20	48	51	77	86	91	103	120	126	143	156	158	165	176	179	192
	30	59	63	94	105	112	126	146	154	175	191	194	202	215	219	235

Capacities for R134a are based on -5°C (20°F) liquid and -5°C (20°F) evaporator temperature. For other evaporator temperatures, these values will change only slightly due to density and latent heat variations.

A recirculation rate of 4:1 was used to calculate the capacity tables. For other recirculation rates, divide 4 by the new recirculation rate and multiply values shown in table to arrive at new capacity.

Example: Calculate the capacity of 40mm (1½") port hand expansion valve at three turns with recirculation rate of 3:1 and a pressure drop of 1.03 bars (15 psi).

Known: The capacity of a 40mm (1½") port hand expansion valve at three turns with a recirculation rate of 4:1 and a pressure drop of 1.03 bars (15 psi) is 91 kW (26 Tons).

$$(a) Q_{n:1} (\text{kW}) = \frac{4}{\text{New Recirculation Rate (n)}} \times Q_{4:1} (\text{kW})$$

$$Q_{3:1} (\text{kW}) = \frac{4}{3} \times 91 \text{ kW}$$

$$Q_{3:1} = 121 \text{ kW}$$

$$(b) Q_{n:1} (\text{Tons}) = \frac{4}{\text{New Recirculation Rate (n)}} \times Q_{4:1} (\text{Tons})$$

$$Q_{3:1} (\text{Tons}) = \frac{4}{3} \times 26 \text{ Tons}$$

$$Q_{3:1} = 35 \text{ Tons}$$

Liquid Overfeed Capacities - Globe "Y" Body

R-404a (KW)

Port Size	Pressure Drop (bar)	Number of Turns														
		1	2	3	4	5	6	7	8	9	10	11	12	13	14	15
32mm	0.34	3.2	17	58	94	101	108	114	120	130						
	0.69	4.6	23	82	132	142	153	161	170	184						
	1.03	5.6	29	101	162	174	187	197	208	225	-	-	-	-	-	-
	1.38	6.5	33	116	187	201	216	227	241	260						
	2.07	7.9	41	143	229	246	264	279	295	318						
40mm	0.34	2.0	3.9	42	77	94	105	112	118	123						
	0.69	2.8	5.5	59	109	134	148	158	167	174						
	1.03	3.5	6.7	72	134	164	181	193	204	213	-	-	-	-	-	-
	1.38	4.0	7.8	83	154	189	209	223	236	246						
	2.07	4.9	9.5	102	189	231	257	274	289	302						
50mm	0.34	67	71	107	119	126	142	166	175	198	216	219	229	244	248	266
	0.69	95	100	151	168	179	202	234	247	280	305	310	324	345	351	376
	1.03	116	123	185	206	219	247	287	303	343	373	380	396	422	430	460
	1.38	134	142	214	238	253	285	331	349	396	431	438	458	487	496	532
	2.07	164	173	262	291	310	349	406	428	485	528	537	561	597	608	651

R-404a (TONS)

Port Size	Pressure Drop (bar)	Number of Turns														
		1	2	3	4	5	6	7	8	9	10	11	12	13	14	15
1 1/4"	5	0.9	4.8	17	27	29	31	33	35	37						
	10	1.3	6.8	24	38	41	44	46	49	53						
	15	1.6	8.3	29	47	50	54	57	60	65	-	-	-	-	-	-
	20	1.9	10	33	54	58	62	65	69	75						
	30	2.3	12	41	66	71	76	80	85	91						
1 1/2"	5	0.6	1.1	12	22	27	30	32	34	35						
	10	0.8	1.6	17	31	38	43	45	48	50						
	15	1.0	1.9	21	38	47	52	56	59	61	-	-	-	-	-	-
	20	1.2	2.2	24	44	54	60	64	68	71						
	30	1.4	2.7	29	54	67	74	79	83	87						
2"	5	19	20	31	34	36	41	48	50	57	62	63	66	70	71	76
	10	27	29	43	48	51	58	67	71	81	88	89	93	99	101	108
	15	33	35	53	59	63	71	82	87	99	107	109	114	121	124	132
	20	39	41	61	68	73	82	95	100	114	124	126	132	140	143	153
	30	47	50	75	84	89	100	117	123	140	152	154	161	172	175	187

Capacities for R404a are based on -5°C (20°F) liquid and -5°C (20°F) evaporator temperature. For other evaporator temperatures, these values will change only slightly due to density and latent heat variations.

A recirculation rate of 4:1 was used to calculate the capacity tables. For other recirculation rates, divide 4 by the new recirculation rate and multiply values shown in table to arrive at new capacity.

Example: Calculate the capacity of 40mm (1 1/2") port hand expansion valve at three turns with recirculation rate of 3:1 and a pressure drop of 1.03 bars (15 psi).

Known: The capacity of a 40mm (1 1/2") port hand expansion valve at three turns with a recirculation rate of 4:1 and a pressure drop of 1.03 bars (15 psi) is 72 kW (21 Tons).

$$(a) Q_{n:1} (kW) = \frac{4}{\text{New Recirculation Rate (n)}} \times Q_{4:1} (kW)$$

$$(b) Q_{n:1} (\text{Tons}) = \frac{4}{\text{New Recirculation Rate (n)}} \times Q_{4:1} (\text{Tons})$$

$$Q_{3:1} (kW) = \frac{4}{3} \times 72 \text{ kW}$$

$$Q_{3:1} (\text{Tons}) = \frac{4}{3} \times 21 \text{ Tons}$$

$$Q_{3:1} = 96 \text{ kW}$$

$$Q_{3:1} = 28 \text{ Tons}$$

Liquid Overfeed Capacities - Globe "Y" Body

R-410a (KW)

Port Size	Pressure Drop (bar)	Number of Turns														
		1	2	3	4	5	6	7	8	9	10	11	12	13	14	15
32mm	0.34	4.4	22	78	126	135	145	153	162	175						
	0.69	6.2	32	111	179	192	205	217	229	247						
	1.03	7.6	39	136	219	235	252	265	281	303	—	—	—	—	—	—
	1.38	8.7	45	157	252	271	291	306	324	350						
	2.07	11	55	192	309	332	356	375	397	429						
40mm	0.34	2.7	5.2	56	104	127	141	150	159	166						
	0.69	3.8	7.4	79	147	180	200	213	225	235						
	1.03	4.7	9.1	97	180	220	244	261	275	288	—	—	—	—	—	—
	1.38	5.4	10	112	208	255	282	301	317	332						
	2.07	6.6	13	137	255	312	346	369	389	407						
50mm	0.34	90	95	144	160	170	192	223	235	267	290	295	308	328	334	358
	0.69	128	135	203	226	241	271	315	333	378	411	418	436	464	473	506
	1.03	156	165	249	277	295	332	386	408	462	503	512	534	569	579	620
	1.38	181	191	288	320	341	384	446	471	534	581	591	617	656	669	716
	2.07	221	234	352	392	417	470	546	576	654	712	724	755	804	819	877

R-410a (TONS)

Port Size	Pressure Drop (bar)	Number of Turns														
		1	2	3	4	5	6	7	8	9	10	11	12	13	14	15
1¼"	5	1.3	6.4	23	36	39	42	44	47	50						
	10	1.8	9.1	32	51	55	59	62	66	71						
	15	2.2	11	39	63	67	72	76	81	87	—	—	—	—	—	—
	20	2.5	13	45	73	78	84	88	93	101						
	30	3.1	16	55	89	95	102	108	114	123						
1½"	5	0.8	1.5	16	30	37	41	43	46	48						
	10	1.1	2.1	23	42	52	57	61	65	68						
	15	1.3	2.6	28	52	63	70	75	79	83	—	—	—	—	—	—
	20	1.6	3.0	32	60	73	81	87	91	95						
	30	1.9	3.7	40	73	90	99	106	112	117						
2"	5	26	27	41	46	49	55	64	68	77	84	85	89	94	96	103
	10	37	39	59	65	69	78	91	96	109	118	120	125	133	136	146
	15	45	47	72	80	85	96	111	117	133	145	147	154	163	166	178
	20	52	55	83	92	98	110	128	135	154	167	170	177	189	192	206
	30	64	67	101	113	120	135	157	166	188	205	208	217	231	235	252

Capacities for R410a are based on -5°C (20°F) liquid and -5°C (20°F) evaporator temperature. For other evaporator temperatures, these values will change only slightly due to density and latent heat variations.

A recirculation rate of 4:1 was used to calculate the capacity tables. For other recirculation rates, divide 4 by the new recirculation rate and multiply values shown in table to arrive at new capacity.

Example: Calculate the capacity of 40mm (1½") port hand expansion valve at three turns with recirculation rate of 3:1 and a pressure drop of 1.03 bars (15 psi).

Known: The capacity of a 40mm (1½") port hand expansion valve at three turns with a recirculation rate of 4:1 and a pressure drop of 1.03 bars (15 psi) is 97 kW (28 Tons).

$$(a) Q_{n:1} (\text{kW}) = \frac{4}{\text{New Recirculation Rate (n)}} \times Q_{4:1} (\text{kW})$$

$$Q_{3:1} (\text{kW}) = \frac{4}{3} \times 97 \text{ kW}$$

$$Q_{3:1} = 129 \text{ kW}$$

$$(b) Q_{n:1} (\text{Tons}) = \frac{4}{\text{New Recirculation Rate (n)}} \times Q_{4:1} (\text{Tons})$$

$$Q_{3:1} (\text{Tons}) = \frac{4}{3} \times 28 \text{ Tons}$$

$$Q_{3:1} = 37 \text{ Tons}$$

Liquid Overfeed Capacities - Globe "Y" Body

R-507a (KW)

Port Size	Pressure Drop (bar)	Number of Turns														
		1	2	3	4	5	6	7	8	9	10	11	12	13	14	15
32mm	0.34	3.2	16	57	92	99	106	112	118	127						
	0.69	4.5	23	81	130	139	150	158	167	180						
	1.03	5.5	28	99	159	171	183	193	204	221	-	-	-	-	-	-
	1.38	6.4	33	114	184	197	212	223	236	255						
	2.07	7.8	40	140	225	242	259	273	289	312						
40mm	0.34	2.0	3.8	41	76	93	103	110	116	121						
	0.69	2.8	5.4	58	107	131	145	155	163	171						
	1.03	3.4	6.6	71	131	160	178	190	200	209	-	-	-	-	-	-
	1.38	3.9	7.6	82	151	185	205	219	231	242						
	2.07	4.8	9.4	100	185	227	252	268	283	296						
50mm	0.34	66	69	105	117	124	140	162	171	194	211	215	224	239	243	261
	0.69	93	98	148	165	175	198	230	242	275	299	304	317	338	344	369
	1.03	114	120	181	202	215	242	281	297	337	366	372	389	414	421	452
	1.38	131	139	209	233	248	279	325	343	389	423	430	449	478	487	521
	2.07	161	170	257	286	304	342	398	420	476	518	527	550	585	596	639

R-507a (TONS)

Port Size	Pressure Drop (bar)	Number of Turns														
		1	2	3	4	5	6	7	8	9	10	11	12	13	14	15
1¼"	5	0.9	4.7	16	26	28	30	32	34	37						
	10	1.3	6.6	23	37	40	43	45	48	52						
	15	1.6	8.1	28	46	49	53	56	59	63	-	-	-	-	-	-
	20	1.8	9.4	33	53	57	61	64	68	73						
	30	2.2	11	40	65	69	74	79	83	90						
1½"	5	0.6	1.1	12	22	27	30	31	33	35						
	10	0.8	1.6	17	31	38	42	45	47	49						
	15	1.0	1.9	20	38	46	51	55	58	60	-	-	-	-	-	-
	20	1.1	2.2	23	44	53	59	63	66	69						
	30	1.4	2.7	29	53	65	72	77	81	85						
2"	5	19	20	30	34	36	40	47	49	56	61	62	65	69	70	75
	10	27	28	43	47	50	57	66	70	79	86	87	91	97	99	106
	15	33	35	52	58	62	70	81	85	97	105	107	112	119	121	130
	20	38	40	60	67	71	80	93	99	112	122	124	129	137	140	150
	30	46	49	74	82	87	98	114	121	137	149	151	158	168	171	184

Capacities for R507a are based on -5°C (20°F) liquid and -5°C (20°F) evaporator temperature. For other evaporator temperatures, these values will change only slightly due to density and latent heat variations.

A recirculation rate of 4:1 was used to calculate the capacity tables. For other recirculation rates, divide 4 by the new recirculation rate and multiply values shown in table to arrive at new capacity.

Example: Calculate the capacity of 40mm (1½") port hand expansion valve at three turns with recirculation rate of 3:1 and a pressure drop of 1.03 bars (15 psi).

Known: The capacity of a 40mm (1½") port hand expansion valve at three turns with a recirculation rate of 4:1 and a pressure drop of 1.03 bars (15 psi) is 71 kW (20 Tons).

$$(a) Q_{n:1} \text{ (kW)} = \frac{4}{\text{New Recirculation Rate (n)}} \times Q_{4:1} \text{ (kW)}$$

$$Q_{3:1} \text{ (kW)} = \frac{4}{3} \times 71 \text{ kW}$$

$$Q_{3:1} = 95 \text{ kW}$$

$$(b) Q_{n:1} \text{ (Tons)} = \frac{4}{\text{New Recirculation Rate (n)}} \times Q_{4:1} \text{ (Tons)}$$

$$Q_{3:1} \text{ (Tons)} = \frac{4}{3} \times 20 \text{ Tons}$$

$$Q_{3:1} = 27 \text{ Tons}$$

Liquid Make Up Capacities - Globe "T" Body

R-717 (KW)

Port Size	Evap. Temp. (°C)	Number of Turns														
		1	2	3	4	5	6	7	8	9	10	11	12	13	14	15
6mm	-5	146	372	453	494	515										
	-20	138	352	427	467	487										
	-30	133	338	411	449	468										
10mm	-5	181	453	634	752	870										
	-20	171	427	598	710	822										
	-30	164	411	575	682	790										
13mm	-5	195	466	668	808	954										
	-20	184	441	631	763	901										
	-30	177	423	607	733	866										
20mm	-5	101	167	543	940	1173	1410									
	-20	95	158	513	888	1108	1331									
	-30	92	152	493	853	1065	1280									
25mm	-5	84	171	550	912	1225	1413									
	-20	79	161	519	861	1157	1335									
	-30	76	155	499	828	1112	1283									
32mm	-5	216	1002	3154	4567	4978	5406	5813	5924	6349	6589					
	-20	204	947	2979	4313	4701	5106	5490	5595	5996	6223					
	-30	196	910	2863	4145	4518	4907	5277	5378	5763	5981					
40mm	-5	3679	4536	5573	6332	7066	7707	8110	8855	9197	9412	9928	10199	10519	10721	10871
	-20	3475	4284	5263	5980	6674	7279	7660	8364	8686	8890	9376	9633	9935	10126	10267
	-30	3340	4117	5059	5747	6414	6995	7362	8038	8348	8544	9011	9258	9548	9732	9868
50mm	-5	3787	4873	5549	6544	7390	8124	9078	9478	10484	10916	11031	11275	11769	11856	12228
	-20	3577	4603	5240	6181	6979	7673	8574	8952	9902	10310	10418	10648	11115	11197	11549
	-30	3438	4423	5036	5940	6708	7375	8240	8604	9517	9909	10013	10234	10683	10762	11100

R-717 (TONS)

Port Size	Evap. Temp. (°F)	Number of Turns														
		1	2	3	4	5	6	7	8	9	10	11	12	13	14	15
¼"	20	41	105	128	140	146										
	0	40	101	123	134	140										
	-20	38	97	117	128	134										
⅜"	20	51	128	179	212	246										
	0	49	123	172	204	236										
	-20	47	117	164	195	226										
½"	20	55	132	189	228	270										
	0	53	126	181	219	258										
	-20	51	121	173	209	247										
¾"	20	29	47	153	266	331	398									
	0	27	45	147	255	318	382									
	-20	26	43	141	244	304	365									
1"	20	24	48	155	258	346	399									
	0	23	46	149	247	332	383									
	-20	22	44	143	236	318	366									
1¼"	20	61	283	891	1291	1407	1528	1643	1674	1794	1862					
	0	58	272	854	1237	1348	1464	1575	1605	1720	1785					
	-20	56	260	818	1184	1291	1402	1507	1536	1646	1708					
1½"	20	1040	1282	1575	1789	1997	2178	2292	2502	2599	2660	2805	2882	2973	3030	3072
	0	997	1229	1510	1715	1914	2088	2197	2399	2491	2550	2689	2763	2850	2904	2945
	-20	954	1176	1445	1642	1832	1998	2103	2296	2384	2440	2574	2644	2727	2780	2818
2"	20	1070	1377	1568	1849	2088	2296	2565	2679	2963	3085	3117	3186	3326	3350	3456
	0	1026	1320	1503	1773	2002	2201	2459	2568	2840	2957	2988	3054	3188	3212	3313
	-20	982	1263	1439	1697	1916	2106	2354	2457	2718	2830	2860	2923	3051	3074	3170

Capacities for R717 are based on 30°C (86°F) condensing temperature and 3.45 bar (50 psig) pressure drop across the valve.

Liquid Make Up Capacities - Globe "T" Body

R-22 (KW)

Port Size	Evap. Temp. (°C)	Number of Turns														
		1	2	3	4	5	6	7	8	9	10	11	12	13	14	15
6mm	-5	24	61	75	81	85										
	-20	21	55	66	73	76	-	-	-	-	-	-	-	-	-	-
	-30	20	51	61	67	70										
10mm	-5	30	75	104	124	143										
	-20	27	66	93	110	128	-	-	-	-	-	-	-	-	-	-
	-30	25	61	86	102	118										
13mm	-5	32	77	110	133	157										
	-20	29	69	98	119	140	-	-	-	-	-	-	-	-	-	-
	-30	26	63	91	110	129										
20mm	-5	17	28	89	155	193	232									
	-20	15	25	80	138	172	207	-	-	-	-	-	-	-	-	-
	-30	14	23	74	128	159	191									
25mm	-5	14	28	91	150	202	233									
	-20	12	25	81	134	180	208	-	-	-	-	-	-	-	-	-
	-30	11	23	75	124	166	192									
32mm	-5	36	165	519	752	820	890	957	976	1045	1085					
	-20	32	147	463	671	731	794	854	870	933	968	-	-	-	-	-
	-30	29	136	428	620	675	733	789	804	861	894					
40mm	-5	606	747	918	1043	1164	1269	1335	1458	1514	1550	1635	1679	1732	1765	1790
	-20	540	666	819	930	1038	1132	1191	1301	1351	1383	1458	1498	1545	1575	1597
	-30	499	615	756	859	959	1046	1100	1201	1248	1277	1347	1384	1427	1455	1475
50mm	-5	624	802	914	1078	1217	1338	1495	1561	1726	1797	1816	1857	1938	1952	2014
	-20	556	716	815	961	1085	1193	1333	1392	1540	1603	1620	1656	1729	1741	1796
	-30	514	661	753	888	1003	1102	1232	1286	1423	1481	1497	1530	1597	1609	1659

R-22 (TONS)

Port Size	Evap. Temp. (°F)	Number of Turns														
		1	2	3	4	5	6	7	8	9	10	11	12	13	14	15
1/4"	20	7.0	18	22	24	25										
	0	6.5	16	20	22	23	-	-	-	-	-	-	-	-	-	-
	-20	5.9	15	18	20	21										
3/8"	20	8.7	22	30	36	42										
	0	8.0	20	28	33	38	-	-	-	-	-	-	-	-	-	-
	-20	7.3	18	26	30	35										
1/2"	20	9.4	22	32	39	46										
	0	8.6	21	30	36	42	-	-	-	-	-	-	-	-	-	-
	-20	7.9	19	27	33	39										
3/4"	20	4.8	8.0	26	45	56	68									
	0	4.5	7.4	24	42	52	62	-	-	-	-	-	-	-	-	-
	-20	4.1	6.8	22	38	48	57									
1"	20	4.0	8.2	26	44	59	68									
	0	3.7	7.5	24	40	54	62	-	-	-	-	-	-	-	-	-
	-20	3.4	6.9	22	37	50	57									
1 1/4"	20	10	48	151	219	239	260	279	285	305	317					
	0	9.5	44	139	202	220	239	257	262	281	291	-	-	-	-	-
	-20	8.7	41	128	185	202	219	236	240	257	267					
1 1/2"	20	177	218	268	304	339	370	390	425	442	452	477	490	505	515	522
	0	163	200	246	280	312	341	358	391	406	416	439	451	465	474	480
	-20	149	184	226	257	286	312	329	359	373	382	402	413	426	435	441
2"	20	182	234	267	314	355	390	436	455	504	524	530	542	565	570	587
	0	167	215	245	289	327	359	401	419	463	482	488	498	520	524	540
	-20	154	198	225	265	300	329	368	384	425	443	447	457	477	481	496

Capacities for R22 are based on 40°C (100°F) condensing temperature and 3.45 bar (50 psig) pressure drop across the valve.

HE/VS

Liquid Make Up Capacities - Globe "T" Body

R-134a (KW)

Port Size	Evap. Temp. (°C)	Number of Turns														
		1	2	3	4	5	6	7	8	9	10	11	12	13	14	15
6mm	-5	21	52	64	70	72	—	—	—	—	—	—	—	—	—	—
	-20	17	44	54	59	61	—	—	—	—	—	—	—	—	—	—
	-30	15	39	48	52	54	—	—	—	—	—	—	—	—	—	—
10mm	-5	25	64	89	106	122	—	—	—	—	—	—	—	—	—	—
	-20	22	54	75	89	103	—	—	—	—	—	—	—	—	—	—
	-30	19	48	67	79	92	—	—	—	—	—	—	—	—	—	—
13mm	-5	27	66	94	114	134	—	—	—	—	—	—	—	—	—	—
	-20	23	55	79	96	113	—	—	—	—	—	—	—	—	—	—
	-30	21	49	71	85	101	—	—	—	—	—	—	—	—	—	—
20mm	-5	14	23	76	132	165	198	—	—	—	—	—	—	—	—	—
	-20	12	20	65	112	139	167	—	—	—	—	—	—	—	—	—
	-30	11	18	57	99	124	149	—	—	—	—	—	—	—	—	—
25mm	-5	12	24	77	128	172	199	—	—	—	—	—	—	—	—	—
	-20	10	20	65	108	146	168	—	—	—	—	—	—	—	—	—
	-30	9	18	58	96	129	149	—	—	—	—	—	—	—	—	—
32mm	-5	30	141	443	642	700	760	817	833	893	927	—	—	—	—	—
	-20	26	119	375	543	591	642	691	704	754	783	—	—	—	—	—
	-30	23	106	333	482	526	571	614	626	671	696	—	—	—	—	—
40mm	-5	517	638	784	890	994	1084	1141	1245	1293	1324	1396	1434	1479	1508	1529
	-20	437	539	662	752	840	916	964	1052	1093	1118	1180	1212	1250	1274	1292
	-30	389	479	589	669	746	814	857	935	971	994	1048	1077	1111	1132	1148
50mm	-5	533	685	780	920	1039	1142	1277	1333	1474	1535	1551	1585	1655	1667	1720
	-20	450	579	659	778	878	965	1079	1126	1246	1297	1311	1340	1398	1409	1453
	-30	400	515	586	691	780	858	959	1001	1107	1153	1165	1191	1243	1252	1291

R-134a (TONS)

Port Size	Evap. Temp. (°F)	Number of Turns														
		1	2	3	4	5	6	7	8	9	10	11	12	13	14	15
¼"	20	6.0	15	19	20	21	—	—	—	—	—	—	—	—	—	—
	0	5.3	14	16	18	19	—	—	—	—	—	—	—	—	—	—
	-20	4.7	12	15	16	17	—	—	—	—	—	—	—	—	—	—
⅜"	20	7.5	19	26	31	36	—	—	—	—	—	—	—	—	—	—
	0	6.6	16	23	27	32	—	—	—	—	—	—	—	—	—	—
	-20	5.8	15	20	24	28	—	—	—	—	—	—	—	—	—	—
½"	20	8.0	19	28	33	39	—	—	—	—	—	—	—	—	—	—
	0	7.1	17	24	29	35	—	—	—	—	—	—	—	—	—	—
	-20	6.3	15	21	26	31	—	—	—	—	—	—	—	—	—	—
¾"	20	4.2	6.9	22	39	48	58	—	—	—	—	—	—	—	—	—
	0	3.7	6.1	20	34	43	51	—	—	—	—	—	—	—	—	—
	-20	3.2	5.4	17	30	38	45	—	—	—	—	—	—	—	—	—
1"	20	3.4	7.0	23	38	50	58	—	—	—	—	—	—	—	—	—
	0	3.0	6.2	20	33	45	51	—	—	—	—	—	—	—	—	—
	-20	2.7	5.5	18	29	39	45	—	—	—	—	—	—	—	—	—
1¼"	20	8.9	41	130	188	205	223	239	244	261	271	—	—	—	—	—
	0	7.9	37	115	166	181	197	212	216	231	240	—	—	—	—	—
	-20	6.9	32	101	146	160	173	186	190	204	211	—	—	—	—	—
1½"	20	151	187	229	261	291	317	334	365	379	387	409	420	433	441	447
	0	134	165	203	231	257	281	295	323	335	343	362	371	383	391	396
	-20	118	145	179	203	227	247	260	284	295	302	318	327	337	344	349
2"	20	156	201	228	269	304	334	374	390	432	449	454	464	484	488	503
	0	138	178	202	238	269	296	331	345	382	398	402	411	429	432	445
	-20	121	156	178	210	237	261	291	304	336	350	354	362	377	380	392

Capacities for R134a are based on 40°C (100°F) condensing temperature and 3.45 bar (50 psig) pressure drop across the valve.

Liquid Make Up Capacities - Globe "T" Body

R-404a (KW)

Port Size	Evap. Temp. (°C)	Number of Turns														
		1	2	3	4	5	6	7	8	9	10	11	12	13	14	15
6mm	-5	13	32	39	43	45										
	-20	10	26	32	35	36	-	-	-	-	-	-	-	-	-	-
	-30	8.8	22	27	30	31										
10mm	-5	16	39	55	65	75										
	-20	13	32	44	53	61	-	-	-	-	-	-	-	-	-	-
	-30	11	27	38	45	53										
13mm	-5	17	40	58	70	83										
	-20	14	33	47	57	67	-	-	-	-	-	-	-	-	-	-
	-30	12	28	40	49	58										
20mm	-5	8.7	14	47	81	102	122									
	-20	7.1	12	38	66	82	99	-	-	-	-	-	-	-	-	-
	-30	6.1	10	33	57	71	85									
25mm	-5	7.2	15	48	79	106	122									
	-20	5.9	12	39	64	86	99	-	-	-	-	-	-	-	-	-
	-30	5.0	10	33	55	74	85									
32mm	-5	19	87	273	395	431	468	503	513	550	570					
	-20	15	70	221	320	349	379	408	416	445	462	-	-	-	-	-
	-30	13	61	190	276	300	326	351	358	383	398					
40mm	-5	318	393	482	548	612	667	702	766	796	815	859	883	911	928	941
	-20	258	318	391	444	496	541	569	621	645	660	696	716	738	752	763
	-30	222	274	336	382	427	465	490	535	555	568	599	616	635	647	656
50mm	-5	328	422	480	566	640	703	786	820	907	945	955	976	1019	1026	1058
	-20	266	342	389	459	518	570	637	665	736	766	774	791	826	832	858
	-30	229	294	335	395	446	490	548	572	633	659	666	681	710	716	738

R-404a (TONS)

Port Size	Evap. Temp. (°F)	Number of Turns														
		1	2	3	4	5	6	7	8	9	10	11	12	13	14	15
1/4"	20	3.8	10	12	13	13										
	0	3.2	8.3	10	11	11	-	-	-	-	-	-	-	-	-	-
	-20	2.8	7.0	8.6	9.4	9.7										
3/8"	20	4.7	12	16	19	22										
	0	4.0	10	14	17	19	-	-	-	-	-	-	-	-	-	-
	-20	3.4	8.6	12	14	16										
1/2"	20	5.0	12	17	21	25										
	0	4.3	10	15	18	21	-	-	-	-	-	-	-	-	-	-
	-20	3.7	8.8	13	15	18										
3/4"	20	2.6	4.3	14	24	30	36									
	0	2.2	3.7	12	21	26	31	-	-	-	-	-	-	-	-	-
	-20	1.9	3.2	10	18	22	27									
1"	20	2.2	4.4	14	24	32	36									
	0	1.9	3.8	12	20	27	31	-	-	-	-	-	-	-	-	-
	-20	1.6	3.2	10	17	23	27									
1 1/4"	20	5.6	26	81	118	129	140	150	153	164	170					
	0	4.8	22	70	101	111	120	129	132	141	146	-	-	-	-	-
	-20	4.1	19	60	86	94	102	110	112	120	125					
1 1/2"	20	95	117	144	164	182	199	209	229	238	243	256	263	272	277	281
	0	82	101	124	141	157	171	180	197	204	209	220	226	234	238	241
	-20	70	86	105	120	134	146	153	168	174	178	188	193	199	203	206
2"	20	98	126	143	169	191	210	234	245	271	282	285	291	304	306	316
	0	84	108	123	145	164	180	202	210	233	242	245	250	261	263	272
	-20	72	92	105	124	140	154	172	179	198	207	209	213	223	224	231

Capacities for R404a are based on 40°C (100°F) condensing temperature and 3.45 bar (50 psig) pressure drop across the valve.

Liquid Make Up Capacities - Globe "T" Body

R-410a (KW)

Port Size	Evap. Temp. (°C)	Number of Turns														
		1	2	3	4	5	6	7	8	9	10	11	12	13	14	15
6mm	-5	21	54	65	72	75	—	—	—	—	—	—	—	—	—	—
	-20	19	48	58	63	66	—	—	—	—	—	—	—	—	—	—
	-30	17	44	53	58	61	—	—	—	—	—	—	—	—	—	—
10mm	-5	26	65	92	109	126	—	—	—	—	—	—	—	—	—	—
	-20	23	58	81	96	111	—	—	—	—	—	—	—	—	—	—
	-30	21	53	74	88	102	—	—	—	—	—	—	—	—	—	—
13mm	-5	28	67	97	117	138	—	—	—	—	—	—	—	—	—	—
	-20	25	60	86	103	122	—	—	—	—	—	—	—	—	—	—
	-30	23	55	79	95	112	—	—	—	—	—	—	—	—	—	—
20mm	-5	15	24	79	136	170	204	—	—	—	—	—	—	—	—	—
	-20	13	21	70	120	150	181	—	—	—	—	—	—	—	—	—
	-30	12	20	64	111	138	166	—	—	—	—	—	—	—	—	—
25mm	-5	12	25	80	132	177	204	—	—	—	—	—	—	—	—	—
	-20	11	22	70	117	157	181	—	—	—	—	—	—	—	—	—
	-30	9.8	20	65	107	144	166	—	—	—	—	—	—	—	—	—
32mm	-5	31	145	456	661	720	782	841	857	919	953	—	—	—	—	—
	-20	28	128	404	585	638	693	745	759	813	844	—	—	—	—	—
	-30	25	118	371	537	585	636	684	697	747	775	—	—	—	—	—
40mm	-5	532	656	806	916	1022	1115	1174	1281	1331	1362	1436	1476	1522	1551	1573
	-20	471	581	714	811	905	987	1039	1135	1178	1206	1272	1307	1348	1374	1393
	-30	433	533	655	745	831	906	954	1041	1081	1107	1167	1199	1237	1261	1278
50mm	-5	548	705	803	947	1069	1176	1314	1371	1517	1580	1596	1631	1703	1715	1769
	-20	485	624	711	838	947	1041	1163	1214	1343	1399	1413	1445	1508	1519	1567
	-30	445	573	652	770	869	955	1068	1115	1233	1284	1297	1326	1384	1394	1438

R-410a (TONS)

Port Size	Evap. Temp. (°F)	Number of Turns														
		1	2	3	4	5	6	7	8	9	10	11	12	13	14	15
¼"	20	6.3	16	19	21	22	—	—	—	—	—	—	—	—	—	—
	0	5.7	15	18	19	20	—	—	—	—	—	—	—	—	—	—
	-20	5.2	13	16	18	18	—	—	—	—	—	—	—	—	—	—
⅜"	20	7.7	19	27	32	37	—	—	—	—	—	—	—	—	—	—
	0	7.1	18	25	29	34	—	—	—	—	—	—	—	—	—	—
	-20	6.5	16	23	27	31	—	—	—	—	—	—	—	—	—	—
½"	20	8.3	20	29	35	41	—	—	—	—	—	—	—	—	—	—
	0	7.6	18	26	32	37	—	—	—	—	—	—	—	—	—	—
	-20	7.0	17	24	29	34	—	—	—	—	—	—	—	—	—	—
¾"	20	4.3	7.2	23	40	50	60	—	—	—	—	—	—	—	—	—
	0	4.0	6.5	21	37	46	55	—	—	—	—	—	—	—	—	—
	-20	3.6	6.0	19	34	42	50	—	—	—	—	—	—	—	—	—
1"	20	3.6	7.3	24	39	52	61	—	—	—	—	—	—	—	—	—
	0	3.3	6.7	22	36	48	55	—	—	—	—	—	—	—	—	—
	-20	3.0	6.1	20	33	44	50	—	—	—	—	—	—	—	—	—
1¼"	20	9.2	43	135	196	213	231	249	254	272	282	—	—	—	—	—
	0	8.5	39	124	179	195	212	228	232	249	258	—	—	—	—	—
	-20	7.7	36	113	163	178	193	208	212	227	235	—	—	—	—	—
1½"	20	158	194	239	271	303	330	347	379	394	403	425	437	450	459	465
	0	144	178	218	248	277	302	318	347	360	369	389	400	412	420	426
	-20	131	162	199	226	252	275	290	316	328	336	355	364	376	383	388
2"	20	162	209	238	280	316	348	389	406	449	467	472	483	504	508	524
	0	148	191	217	256	290	318	356	371	411	428	432	442	461	465	479
	-20	135	174	198	234	264	290	324	339	374	390	394	403	420	423	437

Capacities for R410a are based on 40°C (100°F) condensing temperature and 3.45 bar (50 psig) pressure drop across the valve.

Liquid Make Up Capacities - Globe "T" Body

R-507a (KW)

Port Size	Evap. Temp. (°C)	Number of Turns														
		1	2	3	4	5	6	7	8	9	10	11	12	13	14	15
6mm	-5	12	31	37	41	43	-	-	-	-	-	-	-	-	-	-
	-20	9.8	25	30	33	34	-	-	-	-	-	-	-	-	-	-
	-30	8.4	21	26	28	29	-	-	-	-	-	-	-	-	-	-
10mm	-5	15	37	52	62	72	-	-	-	-	-	-	-	-	-	-
	-20	12	30	42	50	58	-	-	-	-	-	-	-	-	-	-
	-30	10	26	36	43	50	-	-	-	-	-	-	-	-	-	-
13mm	-5	16	39	55	67	79	-	-	-	-	-	-	-	-	-	-
	-20	13	31	45	54	64	-	-	-	-	-	-	-	-	-	-
	-30	11	27	38	46	55	-	-	-	-	-	-	-	-	-	-
20mm	-5	8.4	14	45	78	97	117	-	-	-	-	-	-	-	-	-
	-20	6.7	11	36	63	78	94	-	-	-	-	-	-	-	-	-
	-30	5.8	9.6	31	54	67	81	-	-	-	-	-	-	-	-	-
25mm	-5	6.9	14	46	76	101	117	-	-	-	-	-	-	-	-	-
	-20	5.6	11	37	61	82	94	-	-	-	-	-	-	-	-	-
	-30	4.8	9.8	31	52	70	81	-	-	-	-	-	-	-	-	-
32mm	-5	18	83	261	378	412	448	482	491	526	-	-	-	-	-	-
	-20	14	67	211	305	333	361	388	396	424	-	-	-	-	-	-
	-30	12	57	181	261	285	309	333	339	364	-	-	-	-	-	-
40mm	-5	305	376	462	524	585	638	672	734	762	780	822	845	871	888	900
	-20	246	303	372	423	472	515	542	592	614	629	663	681	703	716	726
	-30	211	260	319	363	405	441	464	507	527	539	568	584	602	614	622
50mm	-5	314	404	460	542	612	673	752	785	868	904	914	934	975	982	1013
	-20	253	326	371	437	494	543	606	633	700	729	737	753	786	792	817
	-30	217	279	318	375	423	465	520	543	600	625	632	645	674	679	700

R-507a (TONS)

Port Size	Evap. Temp. (°F)	Number of Turns														
		1	2	3	4	5	6	7	8	9	10	11	12	13	14	15
¼"	20	3.6	9.2	11	12	13	-	-	-	-	-	-	-	-	-	-
	0	3.1	7.9	9.6	10	11	-	-	-	-	-	-	-	-	-	-
	-20	2.6	6.7	8.1	8.9	9.3	-	-	-	-	-	-	-	-	-	-
⅜"	20	4.5	11	16	19	22	-	-	-	-	-	-	-	-	-	-
	0	3.8	9.6	13	16	18	-	-	-	-	-	-	-	-	-	-
	-20	3.3	8.1	11	14	16	-	-	-	-	-	-	-	-	-	-
½"	20	4.8	12	17	20	24	-	-	-	-	-	-	-	-	-	-
	0	4.1	9.9	14	17	20	-	-	-	-	-	-	-	-	-	-
	-20	3.5	8.4	12	15	17	-	-	-	-	-	-	-	-	-	-
¾"	20	2.5	4.1	13	23	29	35	-	-	-	-	-	-	-	-	-
	0	2.1	3.5	12	20	25	30	-	-	-	-	-	-	-	-	-
	-20	1.8	3.0	10	17	21	25	-	-	-	-	-	-	-	-	-
1"	20	2.1	4.2	14	23	30	35	-	-	-	-	-	-	-	-	-
	0	1.8	3.6	12	19	26	30	-	-	-	-	-	-	-	-	-
	-20	1.5	3.1	10	16	22	25	-	-	-	-	-	-	-	-	-
1¼"	20	5.3	25	78	113	123	134	144	147	157	163	-	-	-	-	-
	0	4.6	21	67	97	106	115	123	126	135	140	-	-	-	-	-
	-20	3.9	18	57	82	90	97	105	107	114	119	-	-	-	-	-
1½"	20	91	112	138	157	175	191	201	219	228	233	246	253	260	265	269
	0	78	96	118	134	150	164	172	188	195	200	211	216	223	227	231
	-20	66	82	100	114	127	139	146	159	166	169	179	184	189	193	196
2"	20	94	121	137	162	183	201	225	235	260	270	273	279	291	294	303
	0	80	103	118	139	157	172	193	201	222	232	234	239	250	252	259
	-20	68	88	100	118	133	146	163	171	189	197	199	203	212	213	220

Capacities for R507a are based on 40°C (100°F) condensing temperature and 3.45 bar (50 psig) pressure drop across the valve.

HEVs

Liquid Make Up Capacities - Angle Body

R-717 (KW)

Port Size	Evap. Temp. (°C)	Number of Turns													
		1	2	3	4	5	6	7	8	9	10	11	12	13	14
6mm	-5	212	418	536	640	707									
	-20	201	395	506	605	667	—	—	—	—	—	—	—	—	—
	-30	193	379	487	581	641									
10mm	-5	223	501	682	835	1030									
	-20	210	473	644	789	973	—	—	—	—	—	—	—	—	—
	-30	202	455	619	758	935									
13mm	-5	160	442	658	835	1009									
	-20	151	418	621	789	953	—	—	—	—	—	—	—	—	—
	-30	145	401	597	758	916									
20mm	-5	101	195	567	905	1208	1448								
	-20	95	184	536	855	1141	1368	—	—	—	—	—	—	—	—
	-30	92	177	515	822	1096	1314								
25mm	-5	101	188	272	870	1211	1392								
	-20	95	178	256	822	1144	1315	—	—	—	—	—	—	—	—
	-30	92	171	246	790	1100	1264								
32mm	-5	240	1156	3272	5019	5500	6085	6168	6426	6990					
	-20	227	1091	3090	4741	5194	5747	5826	6069	6601	—	—	—	—	—
	-30	218	1049	2970	4556	4992	5523	5599	5833	6345					
40mm	-5	108	164	1991	3878	4950	5632	6015	6349	6506					
	-20	102	155	1880	3662	4675	5319	5681	5996	6144	—	—	—	—	—
	-30	98	149	1807	3520	4493	5112	5460	5763	5905					
50mm	-5	3857	3982	5883	6419	7118	7884	8824	9545	10606	11438	11919	12545	12744	13454
	-20	3643	3761	5556	6062	6723	7446	8334	9014	10017	10803	11257	11848	12036	12706
	-30	3501	3615	5340	5826	6461	7157	8010	8664	9627	10383	10819	11387	11567	12212

R-717 (TONS)

Port Size	Evap. Temp. (°F)	Number of Turns													
		1	2	3	4	5	6	7	8	9	10	11	12	13	14
¼"	20	60	118	151	181	200									
	0	58	113	145	173	191	—	—	—	—	—	—	—	—	—
	-20	55	108	139	166	183									
⅜"	20	63	142	193	236	291									
	0	60	136	185	226	279	—	—	—	—	—	—	—	—	—
	-20	58	130	177	217	267									
½"	20	45	125	186	236	285									
	0	43	120	178	226	273	—	—	—	—	—	—	—	—	—
	-20	42	115	171	217	262									
¾"	20	29	55	160	256	341	409								
	0	27	53	154	245	327	392	—	—	—	—	—	—	—	—
	-20	26	51	147	235	313	375								
1"	20	29	53	77	246	342	393								
	0	27	51	74	236	328	377	—	—	—	—	—	—	—	—
	-20	26	49	70	226	314	361								
1¼"	20	68	327	925	1418	1554	1719	1743	1816	1975					
	0	65	313	886	1360	1490	1648	1671	1741	1893	—	—	—	—	—
	-20	62	300	848	1301	1426	1578	1599	1666	1812					
1½"	20	30	46	563	1096	1399	1592	1700	1794	1838					
	0	29	44	539	1050	1341	1526	1629	1720	1762	—	—	—	—	—
	-20	28	42	516	1005	1283	1460	1559	1646	1687					
2"	20	1090	1125	1662	1814	2012	2228	2494	2697	2997	3232	3368	3545	3601	3802
	0	1045	1079	1594	1739	1928	2136	2390	2586	2873	3098	3229	3398	3452	3644
	-20	1000	1032	1525	1664	1846	2044	2288	2475	2750	2966	3090	3252	3304	3488

Capacities for R717 are based on 30°C (86°F) condensing temperature and 3.45 bar (50 psig) pressure drop across the valve.

Liquid Make Up Capacities - Angle Body

R-22 (KW)

Port Size	Evap. Temp. (°C)	Number of Turns													
		1	2	3	4	5	6	7	8	9	10	11	12	13	14
6mm	-5	35	69	88	105	116									
	-20	31	61	79	94	104	-	-	-	-	-	-	-	-	-
	-30	29	57	73	87	96									
10mm	-5	37	83	112	138	170									
	-20	33	74	100	123	151	-	-	-	-	-	-	-	-	-
	-30	30	68	93	113	140									
13mm	-5	26	73	108	138	166									
	-20	24	65	97	123	148	-	-	-	-	-	-	-	-	-
	-30	22	60	89	113	137									
20mm	-5	17	32	93	149	199	238								
	-20	15	29	83	133	177	213	-	-	-	-	-	-	-	-
	-30	14	26	77	123	164	196								
25mm	-5	17	31	45	143	199	229								
	-20	15	28	40	128	178	205	-	-	-	-	-	-	-	-
	-30	14	26	37	118	164	189								
32mm	-5	40	190	539	827	906	1002	1016	1058	1151					
	-20	35	170	481	737	808	894	906	944	1027	-	-	-	-	-
	-30	33	157	444	681	746	826	837	872	948					
40mm	-5	18	27	328	639	815	927	990	1045	1071					
	-20	16	24	292	570	727	827	884	933	956	-	-	-	-	-
	-30	15	22	270	526	672	764	816	861	883					
50mm	-5	635	656	969	1057	1172	1298	1453	1572	1746	1883	1963	2066	2098	2215
	-20	567	585	864	943	1046	1158	1296	1402	1558	1680	1751	1843	1872	1976
	-30	523	540	798	871	966	1070	1197	1295	1439	1552	1617	1702	1729	1825

R-22 (TONS)

Port Size	Evap. Temp. (°F)	Number of Turns													
		1	2	3	4	5	6	7	8	9	10	11	12	13	14
¼"	20	10	20	26	31	34									
	0	9.4	18	24	28	31	-	-	-	-	-	-	-	-	-
	-20	8.6	17	22	26	29									
⅜"	20	11	24	33	40	49									
	0	9.8	22	30	37	46	-	-	-	-	-	-	-	-	-
	-20	9.0	20	28	34	42									
½"	20	7.7	21	32	40	48									
	0	7.1	20	29	37	45	-	-	-	-	-	-	-	-	-
	-20	6.5	18	27	34	41									
¾"	20	4.8	9.4	27	43	58	70								
	0	4.5	8.6	25	40	53	64	-	-	-	-	-	-	-	-
	-20	4.1	7.9	23	37	49	59								
1"	20	4.8	9.0	13	42	58	67								
	0	4.5	8.3	12	38	54	62	-	-	-	-	-	-	-	-
	-20	4.1	7.6	11	35	49	56								
1¼"	20	12	56	157	241	264	292	296	309	336					
	0	11	51	145	222	243	269	273	284	309	-	-	-	-	-
	-20	9.7	47	133	203	223	247	250	260	283					
1½"	20	5.2	7.9	96	186	238	271	289	305	313					
	0	4.8	7.2	88	171	219	249	266	281	288	-	-	-	-	-
	-20	4.4	6.6	81	157	201	228	244	257	264					
2"	20	185	191	283	308	342	379	424	459	510	549	573	603	612	646
	0	170	176	260	284	315	348	390	422	469	506	527	554	563	595
	-20	156	161	238	260	289	320	358	387	430	464	483	509	517	545

Capacities for R22 are based on 40°C (100°F) condensing temperature and 3.45 bar (50 psig) pressure drop across the valve.

HEVs

Liquid Make Up Capacities - Angle Body

R-134a (KW)

Port Size	Evap. Temp. (°C)	Number of Turns													
		1	2	3	4	5	6	7	8	9	10	11	12	13	14
6mm	-5	30	59	75	90	99	—	—	—	—	—	—	—	—	—
	-20	25	50	64	76	84	—	—	—	—	—	—	—	—	—
	-30	22	44	57	68	75	—	—	—	—	—	—	—	—	—
10mm	-5	31	70	96	117	145	—	—	—	—	—	—	—	—	—
	-20	26	60	81	99	122	—	—	—	—	—	—	—	—	—
	-30	24	53	72	88	109	—	—	—	—	—	—	—	—	—
13mm	-5	23	62	93	117	142	—	—	—	—	—	—	—	—	—
	-20	19	53	78	99	120	—	—	—	—	—	—	—	—	—
	-30	17	47	69	88	107	—	—	—	—	—	—	—	—	—
20mm	-5	14	27	80	127	170	204	—	—	—	—	—	—	—	—
	-20	12	23	67	108	144	172	—	—	—	—	—	—	—	—
	-30	11	21	60	96	128	153	—	—	—	—	—	—	—	—
25mm	-5	14	26	38	122	170	196	—	—	—	—	—	—	—	—
	-20	12	22	32	103	144	165	—	—	—	—	—	—	—	—
	-30	11	20	29	92	128	147	—	—	—	—	—	—	—	—
32mm	-5	34	163	460	706	773	856	867	904	983	—	—	—	—	—
	-20	29	137	389	596	653	723	733	763	830	—	—	—	—	—
	-30	25	122	346	530	581	643	651	679	738	—	—	—	—	—
40mm	-5	15	23	280	545	696	792	846	893	915	—	—	—	—	—
	-20	13	19	237	461	588	669	715	754	773	—	—	—	—	—
	-30	11	17	210	410	523	595	635	671	687	—	—	—	—	—
50mm	-5	542	560	827	903	1001	1109	1241	1342	1491	1608	1676	1764	1792	1892
	-20	458	473	699	763	846	937	1048	1134	1260	1359	1416	1491	1514	1598
	-30	407	421	621	678	752	833	932	1008	1120	1208	1259	1325	1346	1421

R-134a (TONS)

Port Size	Evap. Temp. (°F)	Number of Turns													
		1	2	3	4	5	6	7	8	9	10	11	12	13	14
¼"	20	8.7	17	22	26	29	—	—	—	—	—	—	—	—	—
	0	7.7	15	20	23	26	—	—	—	—	—	—	—	—	—
	-20	6.8	13	17	21	23	—	—	—	—	—	—	—	—	—
⅜"	20	9.2	21	28	34	42	—	—	—	—	—	—	—	—	—
	0	8.1	18	25	30	38	—	—	—	—	—	—	—	—	—
	-20	7.1	16	22	27	33	—	—	—	—	—	—	—	—	—
½"	20	6.6	18	27	34	42	—	—	—	—	—	—	—	—	—
	0	5.8	16	24	30	37	—	—	—	—	—	—	—	—	—
	-20	5.1	14	21	27	32	—	—	—	—	—	—	—	—	—
¾"	20	4.2	8.0	23	37	50	60	—	—	—	—	—	—	—	—
	0	3.7	7.1	21	33	44	53	—	—	—	—	—	—	—	—
	-20	3.2	6.3	18	29	39	46	—	—	—	—	—	—	—	—
1"	20	4.2	7.7	11	36	50	57	—	—	—	—	—	—	—	—
	0	3.7	6.8	10	32	44	51	—	—	—	—	—	—	—	—
	-20	3.2	6.0	9	28	39	45	—	—	—	—	—	—	—	—
1¼"	20	9.9	48	135	207	226	250	254	264	288	—	—	—	—	—
	0	8.7	42	119	183	200	222	225	234	255	—	—	—	—	—
	-20	7.7	37	105	161	176	195	198	206	224	—	—	—	—	—
1½"	20	4.4	6.7	82	160	204	232	248	261	268	—	—	—	—	—
	0	3.9	6.0	73	141	180	205	219	231	237	—	—	—	—	—
	-20	3.5	5.2	64	124	159	181	193	204	209	—	—	—	—	—
2"	20	159	164	242	264	293	325	363	393	437	471	491	516	525	554
	0	140	145	214	234	259	287	321	348	386	417	434	457	464	490
	-20	124	128	189	206	228	253	283	306	340	367	382	402	409	431

Capacities for R134a are based on 40°C (100°F) condensing temperature and 3.45 bar (50 psig) pressure drop across the valve.

Liquid Make Up Capacities - Angle Body

R-404a (KW)

Port Size	Evap. Temp. (°C)	Number of Turns													
		1	2	3	4	5	6	7	8	9	10	11	12	13	14
6mm	-5	18	36	46	55	61									
	-20	15	29	38	45	50	-	-	-	-	-	-	-	-	-
	-30	13	25	32	39	43									
10mm	-5	19	43	59	72	89									
	-20	16	35	48	59	72	-	-	-	-	-	-	-	-	-
	-30	13	30	41	50	62									
13mm	-5	14	38	57	72	87									
	-20	11	31	46	59	71	-	-	-	-	-	-	-	-	-
	-30	9.7	27	40	50	61									
20mm	-5	8.7	17	49	78	105	125								
	-20	7.1	14	40	63	85	102	-	-	-	-	-	-	-	-
	-30	6.1	12	34	55	73	87								
25mm	-5	8.7	16	24	75	105	121								
	-20	7.1	13	19	61	85	98	-	-	-	-	-	-	-	-
	-30	6.1	11	16	53	73	84								
32mm	-5	21	100	283	434	476	527	534	556	605					
	-20	17	81	230	352	386	427	433	451	490	-	-	-	-	-
	-30	14	70	198	303	332	367	372	388	422					
40mm	-5	9.3	14	172	336	428	487	521	550	563					
	-20	7.6	11	140	272	347	395	422	445	456	-	-	-	-	-
	-30	6.5	10	120	234	299	340	363	383	393					
50mm	-5	334	345	509	556	616	682	764	826	918	990	1032	1086	1103	1164
	-20	271	279	413	450	499	553	619	670	744	802	836	880	894	944
	-30	233	240	355	387	430	476	533	576	640	691	720	757	769	812

R-404a (TONS)

Port Size	Evap. Temp. (°F)	Number of Turns													
		1	2	3	4	5	6	7	8	9	10	11	12	13	14
¼"	20	5.5	11	14	17	18									
	0	4.7	9.3	12	14	16	-	-	-	-	-	-	-	-	-
	-20	4.0	7.9	10	12	13									
⅜"	20	5.8	13	18	22	27									
	0	4.9	11	15	19	23	-	-	-	-	-	-	-	-	-
	-20	4.2	9.5	13	16	19									
½"	20	4.1	11	17	22	26									
	0	3.6	9.8	15	19	22	-	-	-	-	-	-	-	-	-
	-20	3.0	8.4	12	16	19									
¾"	20	2.6	5.0	15	23	31	37								
	0	2.2	4.3	13	20	27	32	-	-	-	-	-	-	-	-
	-20	1.9	3.7	11	17	23	27								
1"	20	2.6	4.9	7.0	22	31	36								
	0	2.2	4.2	6.0	19	27	31	-	-	-	-	-	-	-	-
	-20	1.9	3.6	5.1	16	23	26								
1¼"	20	6.2	30	85	130	142	157	159	166	181					
	0	5.3	26	73	111	122	135	137	143	155	-	-	-	-	-
	-20	4.5	22	62	95	104	115	117	122	132					
1½"	20	2.8	4.2	51	100	128	145	155	164	168					
	0	2.4	3.6	44	86	110	125	134	141	144	-	-	-	-	-
	-20	2.0	3.1	38	73	94	107	114	120	123					
2"	20	100	103	152	166	184	204	228	246	274	295	308	324	329	347
	0	86	88	131	143	158	175	196	212	236	254	265	279	283	299
	-20	73	75	111	121	135	149	167	181	201	216	226	237	241	255

Capacities for R404a are based on 40°C (100°F) condensing temperature and 3.45 bar (50 psig) pressure drop across the valve.

Liquid Make Up Capacities - Angle Body

R-410a (KW)

Port Size	Evap. Temp. (°C)	Number of Turns													
		1	2	3	4	5	6	7	8	9	10	11	12	13	14
6mm	-5	31	60	78	93	102									
	-20	27	54	69	82	91	—	—	—	—	—	—	—	—	—
	-30	25	49	63	75	83									
10mm	-5	32	73	99	121	149									
	-20	29	64	87	107	132	—	—	—	—	—	—	—	—	—
	-30	26	59	80	98	121									
13mm	-5	23	64	95	121	146									
	-20	21	57	84	107	129	—	—	—	—	—	—	—	—	—
	-30	19	52	77	98	119									
20mm	-5	15	28	82	131	175	210								
	-20	13	25	73	116	155	186	—	—	—	—	—	—	—	—
	-30	12	23	67	106	142	170								
25mm	-5	15	27	39	126	175	201								
	-20	13	24	35	111	155	178	—	—	—	—	—	—	—	—
	-30	12	22	32	102	142	164								
32mm	-5	35	167	473	726	796	880	893	930	1011					
	-20	31	148	419	643	705	780	790	823	896	—	—	—	—	—
	-30	28	136	385	590	647	716	725	756	822					
40mm	-5	16	24	288	561	716	815	870	919	941					
	-20	14	21	255	497	634	722	771	813	834	—	—	—	—	—
	-30	13	19	234	456	582	662	707	747	765					
50mm	-5	558	576	851	929	1030	1141	1277	1381	1535	1655	1725	1815	1844	1947
	-20	494	510	754	822	912	1010	1131	1223	1359	1466	1527	1607	1633	1724
	-30	454	468	692	755	837	927	1038	1122	1247	1345	1402	1475	1499	1582

R-410a (TONS)

Port Size	Evap. Temp. (°F)	Number of Turns													
		1	2	3	4	5	6	7	8	9	10	11	12	13	14
¼"	20	9.1	18	23	27	30									
	0	8.3	16	21	25	28	—	—	—	—	—	—	—	—	—
	-20	7.6	15	19	23	25									
⅜"	20	9.5	21	29	36	44									
	0	8.7	20	27	33	40	—	—	—	—	—	—	—	—	—
	-20	8.0	18	24	30	37									
½"	20	6.9	19	28	36	43									
	0	6.3	17	26	33	40	—	—	—	—	—	—	—	—	—
	-20	5.7	16	23	30	36									
¾"	20	4.3	8.3	24	39	52	62								
	0	4.0	7.6	22	35	47	57	—	—	—	—	—	—	—	—
	-20	3.6	7.0	20	32	43	52								
1"	20	4.3	8.0	12	37	52	60								
	0	4.0	7.4	11	34	47	55	—	—	—	—	—	—	—	—
	-20	3.6	6.7	10	31	43	50								
1¼"	20	10	49	140	215	235	260	264	275	299					
	0	9.4	45	128	197	216	238	242	252	274	—	—	—	—	—
	-20	8.6	41	117	179	196	217	220	229	250					
1½"	20	4.6	7.0	85	166	212	241	258	272	279					
	0	4.2	6.4	78	152	194	221	236	249	255	—	—	—	—	—
	-20	3.9	5.8	71	138	177	201	215	227	232					
2"	20	165	170	252	275	305	338	378	409	454	490	510	537	546	576
	0	151	156	231	252	279	309	346	374	416	448	467	492	499	527
	-20	138	142	210	229	254	282	315	341	379	409	426	448	455	480

Capacities for R410a are based on 40°C (100°F) condensing temperature and 3.45 bar (50 psig) pressure drop across the valve.

Liquid Make Up Capacities - Angle Body

R-507a (KW)

Port Size	Evap. Temp. (°C)	Number of Turns													
		1	2	3	4	5	6	7	8	9	10	11	12	13	14
6mm	-5	18	35	44	53	59	-	-	-	-	-	-	-	-	-
	-20	14	28	36	43	47	-	-	-	-	-	-	-	-	-
	-30	12	24	31	37	40	-	-	-	-	-	-	-	-	-
10mm	-5	18	42	57	69	85	-	-	-	-	-	-	-	-	-
	-20	15	33	46	56	69	-	-	-	-	-	-	-	-	-
	-30	13	29	39	48	59	-	-	-	-	-	-	-	-	-
13mm	-5	13	37	54	69	84	-	-	-	-	-	-	-	-	-
	-20	11	30	44	56	67	-	-	-	-	-	-	-	-	-
	-30	9.2	25	38	48	58	-	-	-	-	-	-	-	-	-
20mm	-5	8.4	16	47	75	100	120	-	-	-	-	-	-	-	-
	-20	6.7	13	38	60	81	97	-	-	-	-	-	-	-	-
	-30	5.8	11	32	52	69	83	-	-	-	-	-	-	-	-
25mm	-5	8.4	16	22	72	100	115	-	-	-	-	-	-	-	-
	-20	6.7	13	18	58	81	93	-	-	-	-	-	-	-	-
	-30	5.8	11	16	50	69	80	-	-	-	-	-	-	-	-
32mm	-5	20	96	271	416	456	504	511	532	579	-	-	-	-	-
	-20	16	77	219	335	367	406	412	429	467	-	-	-	-	-
	-30	14	66	187	287	315	348	353	368	400	-	-	-	-	-
40mm	-5	8.9	14	165	321	410	467	498	526	539	-	-	-	-	-
	-20	7.2	11	133	259	331	376	402	424	435	-	-	-	-	-
	-30	6.2	9.4	114	222	283	322	344	364	372	-	-	-	-	-
50mm	-5	319	330	487	532	590	653	731	791	879	947	987	1039	1056	1114
	-20	258	266	393	429	476	527	589	638	709	764	796	838	851	899
	-30	221	228	337	367	408	451	505	546	607	655	682	718	730	770

R-507a (TONS)

Port Size	Evap. Temp. (°F)	Number of Turns													
		1	2	3	4	5	6	7	8	9	10	11	12	13	14
¼"	20	5.3	10	13	16	17	-	-	-	-	-	-	-	-	-
	0	4.5	8.9	11	14	15	-	-	-	-	-	-	-	-	-
	-20	3.8	7.5	10	12	13	-	-	-	-	-	-	-	-	-
⅜"	20	5.5	12	17	21	26	-	-	-	-	-	-	-	-	-
	0	4.7	11	14	18	22	-	-	-	-	-	-	-	-	-
	-20	4.0	9.0	12	15	19	-	-	-	-	-	-	-	-	-
½"	20	4.0	11	16	21	25	-	-	-	-	-	-	-	-	-
	0	3.4	9.4	14	18	21	-	-	-	-	-	-	-	-	-
	-20	2.9	8.0	12	15	18	-	-	-	-	-	-	-	-	-
¾"	20	2.5	4.8	14	22	30	36	-	-	-	-	-	-	-	-
	0	2.1	4.1	12	19	26	31	-	-	-	-	-	-	-	-
	-20	1.8	3.5	10	16	22	26	-	-	-	-	-	-	-	-
1"	20	2.5	4.7	6.7	22	30	34	-	-	-	-	-	-	-	-
	0	2.1	4.0	5.8	18	26	30	-	-	-	-	-	-	-	-
	-20	1.8	3.4	4.9	16	22	25	-	-	-	-	-	-	-	-
1¼"	20	5.9	29	81	124	136	151	153	159	173	-	-	-	-	-
	0	5.1	25	69	107	117	129	131	136	148	-	-	-	-	-
	-20	4.3	21	59	90	99	110	111	116	126	-	-	-	-	-
1½"	20	2.7	4.1	49	96	123	139	149	157	161	-	-	-	-	-
	0	2.3	3.5	42	82	105	120	128	135	138	-	-	-	-	-
	-20	1.9	2.9	36	70	89	101	108	114	117	-	-	-	-	-
2"	20	96	99	146	159	176	195	219	236	263	283	295	311	316	333
	0	82	84	125	136	151	167	187	203	225	243	253	266	270	285
	-20	69	72	106	116	128	142	159	172	191	206	215	226	229	242

Capacities for R507a are based on 40°C (100°F) condensing temperature and 3.45 bar (50 psig) pressure drop across the valve.

HEVs

Liquid Make Up Capacities - Globe "Y" Body

R-717 (KW)

Port Size	Evap. Temp. (°C)	Number of Turns														
		1	2	3	4	5	6	7	8	9	10	11	12	13	14	15
32mm	-5	174	891	3122	5026	5395	5785	6102	6457	6969	—	—	—	—	—	—
	-20	164	842	2949	4747	5096	5464	5763	6098	6582	—	—	—	—	—	—
	-30	158	809	2834	4563	4897	5251	5539	5861	6326	—	—	—	—	—	—
40mm	-5	108	209	2235	4139	5068	5618	5991	6321	6610	—	—	—	—	—	—
	-20	102	197	2111	3909	4787	5306	5658	5970	6243	—	—	—	—	—	—
	-30	98	190	2028	3757	4600	5100	5438	5738	6000	—	—	—	—	—	—
50mm	-5	3596	3798	5730	6377	6784	7644	8883	9371	10631	11567	11762	12277	13071	13311	14261
	-20	3396	3587	5411	6023	6407	7219	8390	8850	10040	10925	11109	11595	12345	12572	13469
	-30	3264	3447	5201	5788	6158	6939	8063	8506	9650	10499	10676	11144	11864	12082	12945

R-717 (TONS)

Port Size	Evap. Temp. (°F)	Number of Turns														
		1	2	3	4	5	6	7	8	9	10	11	12	13	14	15
1/4"	20	49	252	882	1420	1525	1635	1724	1825	1969	—	—	—	—	—	—
	0	47	241	846	1362	1462	1567	1653	1749	1888	—	—	—	—	—	—
	-20	45	231	810	1303	1399	1500	1582	1674	1807	—	—	—	—	—	—
1/2"	20	30	59	632	1170	1432	1588	1693	1786	1868	—	—	—	—	—	—
	0	29	57	605	1121	1373	1522	1623	1712	1791	—	—	—	—	—	—
	-20	28	54	579	1073	1314	1457	1553	1639	1714	—	—	—	—	—	—
2"	20	1016	1073	1619	1802	1917	2160	2510	2648	3004	3269	3324	3469	3694	3762	4030
	0	974	1029	1552	1727	1838	2071	2406	2538	2880	3133	3186	3326	3541	3606	3863
	-20	932	985	1485	1653	1759	1982	2303	2429	2756	2999	3049	3183	3389	3451	3697

R-22 (KW)

Port Size	Evap. Temp. (°C)	Number of Turns														
		1	2	3	4	5	6	7	8	9	10	11	12	13	14	15
32mm	-5	29	147	514	828	888	953	1005	1063	1147	—	—	—	—	—	—
	-20	26	131	459	738	792	850	896	948	1024	—	—	—	—	—	—
	-30	24	121	424	682	732	785	828	876	946	—	—	—	—	—	—
40mm	-5	18	34	368	682	835	925	986	1041	1088	—	—	—	—	—	—
	-20	16	31	328	608	744	825	880	928	971	—	—	—	—	—	—
	-30	15	28	303	562	688	762	813	858	897	—	—	—	—	—	—
50mm	-5	592	625	943	1050	1117	1259	1463	1543	1750	1905	1937	2022	2152	2192	2348
	-20	528	558	842	937	996	1123	1305	1376	1561	1699	1728	1803	1920	1955	2095
	-30	488	515	777	865	920	1037	1205	1271	1442	1569	1596	1666	1773	1806	1935

R-22 (TONS)

Port Size	Evap. Temp. (°F)	Number of Turns														
		1	2	3	4	5	6	7	8	9	10	11	12	13	14	15
1/4"	20	8.4	43	150	241	259	278	293	310	335	—	—	—	—	—	—
	0	7.7	39	138	222	238	256	270	285	308	—	—	—	—	—	—
	-20	7.1	36	127	204	219	235	247	262	282	—	—	—	—	—	—
1/2"	20	5.2	10	107	199	243	270	288	304	318	—	—	—	—	—	—
	0	4.8	9.2	99	183	224	248	265	279	292	—	—	—	—	—	—
	-20	4.4	8.5	91	168	205	228	243	256	268	—	—	—	—	—	—
2"	20	173	182	275	306	326	367	427	450	511	556	565	590	628	639	685
	0	159	168	253	282	300	338	393	414	470	511	520	543	578	588	630
	-20	146	154	232	259	275	310	360	380	431	469	477	498	530	540	578

Capacities for R717 are based on 30°C (86°F) condensing temperature and 3.45 bar (50 psig) pressure drop across the valve.

Capacities for R22 are based on 40°C (100°F) condensing temperature and 3.45 bar (50 psig) pressure drop across the valve.

Liquid Make Up Capacities - Globe "Y" Body

R-134a (KW)

Port Size	Evap. Temp. (°C)	Number of Turns														
		1	2	3	4	5	6	7	8	9	10	11	12	13	14	15
32mm	-5	24	125	439	707	759	814	858	908	980	-	-	-	-	-	-
	-20	21	106	371	597	641	687	725	767	828	-	-	-	-	-	-
	-30	18	94	330	531	570	611	644	682	736	-	-	-	-	-	-
40mm	-5	15	29	314	582	713	790	842	889	930	-	-	-	-	-	-
	-20	13	25	266	492	602	668	712	751	785	-	-	-	-	-	-
	-30	11	22	236	437	535	593	633	668	698	-	-	-	-	-	-
50mm	-5	506	534	806	897	954	1075	1249	1318	1495	1627	1654	1726	1838	1872	2005
	-20	427	451	681	758	806	908	1055	1113	1263	1374	1397	1459	1553	1582	1694
	-30	380	401	605	673	716	807	938	990	1123	1222	1242	1297	1380	1406	1506

R-134a (TONS)

Port Size	Evap. Temp. (°F)	Number of Turns														
		1	2	3	4	5	6	7	8	9	10	11	12	13	14	15
1/4"	20	7.2	37	129	207	222	238	251	266	287	-	-	-	-	-	-
	0	6.3	32	114	183	197	211	222	235	254	-	-	-	-	-	-
	-20	5.6	29	100	161	173	186	196	207	223	-	-	-	-	-	-
1/2"	20	4.4	8.6	92	170	209	231	247	260	272	-	-	-	-	-	-
	0	3.9	7.6	81	151	185	205	218	230	241	-	-	-	-	-	-
	-20	3.5	6.7	72	133	163	180	192	203	212	-	-	-	-	-	-
2"	20	148	156	236	262	279	315	366	386	438	476	484	505	538	548	587
	0	131	138	209	232	247	278	324	341	387	421	428	447	476	485	519
	-20	115	122	184	205	218	245	285	301	341	371	377	394	419	427	457

R-404a (KW)

Port Size	Evap. Temp. (°C)	Number of Turns														
		1	2	3	4	5	6	7	8	9	10	11	12	13	14	15
32mm	-5	15	77	270	435	467	501	528	559	603	-	-	-	-	-	-
	-20	12	63	219	353	379	406	428	453	489	-	-	-	-	-	-
	-30	11	54	188	303	326	349	368	390	421	-	-	-	-	-	-
40mm	-5	9.3	18	193	358	439	486	519	547	572	-	-	-	-	-	-
	-20	7.6	15	157	290	356	394	420	443	464	-	-	-	-	-	-
	-30	6.5	13	135	250	306	339	362	382	399	-	-	-	-	-	-
50mm	-5	311	329	496	552	587	662	769	811	920	1001	1018	1063	1131	1152	1234
	-20	252	266	402	447	476	536	623	657	746	812	825	861	917	934	1001
	-30	217	229	346	385	410	461	536	566	642	698	710	741	789	804	861

R-404a (TONS)

Port Size	Evap. Temp. (°F)	Number of Turns														
		1	2	3	4	5	6	7	8	9	10	11	12	13	14	15
1/4"	20	4.5	23	81	130	139	149	158	167	180	-	-	-	-	-	-
	0	3.9	20	69	112	120	128	136	143	155	-	-	-	-	-	-
	-20	3.3	17	59	95	102	109	115	122	132	-	-	-	-	-	-
1/2"	20	2.8	5.4	58	107	131	145	155	163	171	-	-	-	-	-	-
	0	2.4	4.6	50	92	113	125	133	140	147	-	-	-	-	-	-
	-20	2.0	4.0	42	78	96	106	113	120	125	-	-	-	-	-	-
2"	20	93	98	148	165	175	197	229	242	275	299	304	317	338	344	368
	0	80	84	127	142	151	170	197	208	236	257	261	273	290	296	317
	-20	68	72	108	121	128	145	168	177	201	219	223	232	247	252	270

Capacities for R134a and R404a are based on 40°C (100°F) condensing temperature and 3.45 bar (50 psig) pressure drop across the valve.

HEVs

Liquid Make Up Capacities - Globe "Y" Body

R-410a (KW)

Port Size	Evap. Temp. (°C)	Number of Turns														
		1	2	3	4	5	6	7	8	9	10	11	12	13	14	15
32mm	-5	25	129	452	727	781	837	883	934	1008						
	-20	22	114	400	644	691	741	782	827	893	—	—	—	—		—
	-30	20	105	367	591	634	680	718	759	819						
40mm	-5	16	30	323	599	733	813	867	915	956						
	-20	14	27	286	530	649	720	768	810	847	—	—	—	—		—
	-30	13	25	263	487	596	661	704	743	777						
50mm	-5	520	550	829	923	982	1106	1285	1356	1538	1674	1702	1776	1891	1926	2064
	-20	461	487	734	817	869	979	1138	1201	1362	1482	1507	1573	1675	1705	1827
	-30	423	447	674	750	798	899	1045	1102	1250	1360	1383	1444	1537	1565	1677

R-410a (TONS)

Port Size	Evap. Temp. (°F)	Number of Turns														
		1	2	3	4	5	6	7	8	9	10	11	12	13	14	15
1/4"	20	7.5	38	134	215	231	248	261	276	298						
	0	6.8	35	122	197	211	227	239	253	273	—	—	—	—		—
	-20	6.2	32	112	180	193	207	218	231	249						
1/2"	20	4.6	8.9	96	177	217	241	256	271	283						
	0	4.2	8.2	88	162	199	220	235	248	259	—	—	—	—		—
	-20	3.9	7.5	80	148	181	201	214	226	236						
2"	20	154	163	245	273	290	327	380	401	455	495	504	526	560	570	611
	0	141	149	225	250	266	300	348	367	417	453	461	481	512	522	559
	-20	128	136	205	228	242	273	317	335	380	413	420	438	467	475	509

R-507a (KW)

Port Size	Evap. Temp. (°C)	Number of Turns														
		1	2	3	4	5	6	7	8	9	10	11	12	13	14	15
32mm	-5	14	74	259	416	447	479	505	535	577						
	-20	12	60	209	336	360	386	408	431	466	—	—	—	—		—
	-30	10	51	179	288	309	331	349	370	399						
40mm	-5	8.9	17	185	343	420	465	496	524	548						
	-20	7.2	14	149	276	339	375	400	422	442	—	—	—	—		—
	-30	6.2	12	128	237	290	322	343	362	378						
50mm	-5	298	315	475	528	562	633	736	776	881	958	974	1017	1083	1103	1181
	-20	240	254	383	426	453	511	593	626	710	773	786	820	873	889	953
	-30	206	217	328	365	388	438	509	536	609	662	673	703	748	762	816

R-507a (TONS)

Port Size	Evap. Temp. (°F)	Number of Turns														
		1	2	3	4	5	6	7	8	9	10	11	12	13	14	15
1/4"	20	4.3	22	77	124	134	143	151	160	173						
	0	3.7	19	66	107	114	123	129	137	148	—	—	—	—		—
	-20	3.1	16	56	91	97	104	110	116	125						
1/2"	20	2.7	5.2	55	102	126	139	148	157	164						
	0	2.3	4.4	47	88	108	119	127	134	140	—	—	—	—		—
	-20	1.9	3.8	40	75	91	101	108	114	119						
2"	20	89	94	142	158	168	189	220	232	263	286	291	304	324	330	353
	0	76	81	122	135	144	162	188	199	226	245	250	261	277	282	303
	-20	65	68	103	115	122	138	160	169	191	208	212	221	235	240	257

Capacities for R410a and R507a are based on 40°C (100°F) condensing temperature and 3.45 bar (50 psig) pressure drop across the valve.

Rapid Purger (V200)

The Model V200 Rapid Purger is a unique energy-saving device designed to efficiently remove foreign non-condensable gases from ammonia refrigeration systems.

Non-condensables like air, hydrogen, nitrogen, and hydrocarbon gases reduce the overall capacity of the refrigeration system. Higher pressures, which in turn causes longer compressor runtime, longer condenser fan runtime, higher compressor discharge temperatures, increase compressor power costs, increase wear and tear on equipment, increase leaks, reduce system efficiency, increase overall system energy costs are all consequences of non-condensables in the refrigeration system.

In a refrigeration system non-condensables can be introduced by:

- Inadequate system evacuation such as servicing compressors, strainers, valves, start-up, etc.
- Refrigerant additions
- Leaks from valve stem packing, bonnet gasket, compressor shaft seal, control transducers, etc.
- Separation of ammonia molecules (hydrogen and nitrogen)
- Compressor oil breakdown (hydrocarbon gases)

The base V200 Rapid Purger removes the non-condensable gases from four purge points. With the addition of purge points the auto purger is capable of purging a total of 20 purge points. This leads to lower condensing pressure, runtime of the compressors, and operating costs.

Non-condensable indicators are excessively high condensing temperatures/pressures and saturated temperature/pressure deviations. One indicator is a higher saturated condensing pressure/temperature at the condenser for the given outdoor air wet bulb and heat rejection load. Another indicator is the increasing difference between the observed condensing pressure and the saturation pressure corresponding to the liquid refrigerant temperature exiting the condenser.

Product Features

- Smaller compact design with equivalent capacity of our current model
- Light weight 29.5 kg (65 lbs)
- Proprietary microprocessor control for all sensing and control functions
- Factory calibrated and wired
- Auto or manual cycling capabilities
- Up to 20 "Purge Points"
- Automatically adjusts vent pressures
- Energy saving sleep mode that will activate with lack of non-condensables
- Electronic level, temperature, and pressure monitoring for improved performance
- Records number of purger cycles and times for each purge point during a 7 day period
- Purger is made of corrosion resistant material



Auto Purger

Modulating Refrigerant Valve (MVS)

The MVS Industrial Electronic Control Valve utilizes electronic controls to regulate both liquid and vapor refrigerant flows. MVS valves can be applied to manage liquid levels in vessels, superheat for direct expansion evaporators, brine temperature in chillers, hot gas for defrost, and countless other installations.

Function

MVS valves employ a linear magnetic actuator for valve positioning. This actuator reacts to the control input provided by the process controller. Together, the valve and controller can provide unmatched precision and versatility in a variety of applications.

Specifications

Power Supply: AC 24V \pm 20% (45...65Hz) 12W
 DC 20...30V (0.5/2A max.)
 Single Output DC 0/2 - 10V or DC 0/4 - 20mA
 Material: Body Steel/CrNi Steel
 Seat/Piston CrNi Steel
 Sealing Disk/O-ring PTFE/CR
 Pipe connection (Socket Weld): 33.7mm

Features

- CE conformity to EMV requirements
- NEMA 3R (IP65) electrical construction
- Conform to UL and CSA
- Complies with Pressure Equipment Directive (PED) 97/23/EC
- Hermetically sealed
- High resolution and control accuracy
- Precise positioning control and position feedback signal
- Outfitted with position feedback
- Fast response (0-100% Open < 1 sec.)
- On-board diagnostics
- Replaceable capacity cartridges
- Corrosion resistant construction
- Spring return offers tight shut-off in the event of a power failure



General Information

MVS	Port Size	Plug	Flow Coefficient	
			Kv	Cv
MVS661.25-016N	3/8"	Standard	0.16	0.19
MVS661.25-0.4N	1/2"	Standard	0.40	0.47
MVS661.25-1.0N	3/4"	Standard	1.00	1.17
MVS661.25-2.5N	1"	Standard	2.50	2.92
MVS661.25-6.3N	1 1/4"	Standard	6.29	7.35

Liquid Make Up Capacities (MVS)

Intermediate to Low Pressure Receiver (LPR)

R-717 (KW)

Evap. Temp. (°C)	661.25-.16N	661.25-.4N	661.25-1.0N	661.25-2.5N	661.25-6.3N
-40	18	45	112	280	705
-35	19	46	115	286	720
-30	19	47	117	292	734
-20	20	49	122	304	764
-15	20	50	124	310	779
-10	21	51	126	315	794

R-717 (TONS)

Evap. Temp. (°F)	661.25-.16N	661.25-.4N	661.25-1.0N	661.25-2.5N	661.25-6.3N
-40	5.2	13	32	80	200
-30	5.3	13	33	81	205
-20	5.4	13	33	83	210
-10	5.5	14	34	85	214
0	5.7	14	35	87	219
10	5.8	14	36	89	224

R-22 (KW)

Evap. Temp. (°C)	661.25-.16N	661.25-.4N	661.25-1.0N	661.25-2.5N	661.25-6.3N
-40	2.6	6.5	16	40	101
-35	2.7	6.7	17	42	105
-30	2.8	7.0	17	44	110
-20	3.1	7.6	19	47	119
-15	3.2	7.9	20	49	124
-10	3.3	8.2	20	51	128

R-22 (TONS)

Evap. Temp. (°F)	661.25-.16N	661.25-.4N	661.25-1.0N	661.25-2.5N	661.25-6.3N
-40	0.8	1.9	4.8	12	30
-30	0.8	2.0	5.0	12	31
-20	0.8	2.1	5.2	13	33
-10	0.9	2.2	5.5	14	34
0	0.9	2.3	5.7	14	36
10	1.0	2.4	5.9	15	37

R-134a (KW)

Evap. Temp. (°C)	661.25-.16N	661.25-.4N	661.25-1.0N	661.25-2.5N	661.25-6.3N
-40	2.0	4.8	12	30	76
-35	2.1	5.1	13	32	80
-30	2.2	5.5	14	34	85
-20	2.5	6.1	15	38	96
-15	2.6	6.5	16	40	102
-10	2.8	6.9	17	43	108

R-134a (TONS)

Evap. Temp. (°F)	661.25-.16N	661.25-.4N	661.25-1.0N	661.25-2.5N	661.25-6.3N
-40	0.6	1.5	3.6	9	23
-30	0.6	1.6	3.9	10	24
-20	0.7	1.7	4.1	10	26
-10	0.7	1.8	4.4	11	28
0	0.8	1.9	4.7	12	29
10	0.8	2.0	5.0	12	31

R717 capacities are based on 30°C (86°F) condensing temperature and 0.34 bar (5 psig) pressure drop across the valve

R22 and R134a capacities are based on 40°C (100°F) condensing temperature and 0.34 bar (5 psig) pressure drop across the valve

Liquid Make Up Capacities (MVS)

Intermediate to Low Pressure Receiver (LPR)

R-404a (KW)

Evap. Temp. (°C)	661.25-.16N	661.25-.4N	661.25-1.0N	661.25-2.5N	661.25-6.3N
-40	1.1	2.7	7	17	42
-35	1.2	2.9	7	18	45
-30	1.3	3.1	8	19	49
-20	1.5	3.6	9	23	57
-15	1.6	3.9	10	24	61
-10	1.7	4.2	10	26	65

R-404a (TONS)

Evap. Temp. (°F)	661.25-.16N	661.25-.4N	661.25-1.0N	661.25-2.5N	661.25-6.3N
-40	0.3	0.8	2.1	5.1	13
-30	0.4	0.9	2.2	5.6	14
-20	0.4	1.0	2.4	6.1	15
-10	0.4	1.1	2.6	6.6	17
0	0.5	1.1	2.9	7.1	18
10	0.5	1.2	3.1	7.7	19

R-410a (KW)

Evap. Temp. (°C)	661.25-.16N	661.25-.4N	661.25-1.0N	661.25-2.5N	661.25-6.3N
-40	2.2	5.6	14	35	87
-35	2.4	5.8	14	36	91
-30	2.5	6.1	15	38	95
-20	2.7	6.6	17	41	104
-15	2.8	6.9	17	43	108
-10	2.9	7.2	18	45	113

R-410a (TONS)

Evap. Temp. (°F)	661.25-.16N	661.25-.4N	661.25-1.0N	661.25-2.5N	661.25-6.3N
-40	0.7	1.7	4.2	10	26
-30	0.7	1.8	4.4	11	28
-20	0.7	1.8	4.6	11	29
-10	0.8	1.9	4.8	12	30
0	0.8	2.0	5.0	13	32
10	0.9	2.1	5.3	13	33

R-507a (KW)

Evap. Temp. (°C)	661.25-.16N	661.25-.4N	661.25-1.0N	661.25-2.5N	661.25-6.3N
-40	1.0	2.5	6.3	16	39
-35	1.1	2.7	6.8	17	43
-30	1.2	3.0	7.4	18	46
-20	1.4	3.5	8.6	21	54
-15	1.5	3.7	9.3	23	58
-10	1.6	4.0	9.9	25	63

R-507a (TONS)

Evap. Temp. (°F)	661.25-.16N	661.25-.4N	661.25-1.0N	661.25-2.5N	661.25-6.3N
-40	0.3	0.8	1.9	4.9	12
-30	0.3	0.9	2.1	5.3	13
-20	0.4	0.9	2.3	5.8	15
-10	0.4	1.0	2.5	6.3	16
0	0.4	1.1	2.7	6.8	17
10	0.5	1.2	3.0	7.4	19

R404a, R410a and R507a capacities are based on 40°C (100°F) condensing temperature and 0.34 bar (5 psig) pressure drop across the valve

Liquid Make Up Capacities (MVS)

High Pressure Receiver (HPR) to Intermediate

R-717 (KW)

Evap. Temp. (°C)	661.25-.16N	661.25-.4N	661.25-1.0N	661.25-2.5N	661.25-6.3N
-40	58	143	355	886	2229
-35	59	146	362	904	2276
-30	60	149	370	923	2322
-20	62	155	385	960	2416
-15	64	158	392	979	2464
-10	65	161	400	998	2511
-5	66	164	407	1016	2558
0	67	167	415	1035	2606
5	69	170	422	1054	2654
10	70	173	430	1073	2702

R-717 (TONS)

Evap. Temp. (°F)	661.25-.16N	661.25-.4N	661.25-1.0N	661.25-2.5N	661.25-6.3N
-40	16	41	101	252	634
-30	17	41	103	258	649
-20	17	42	106	264	663
-10	18	43	108	269	678
0	18	44	110	275	693
10	18	45	113	281	708
20	19	46	115	287	723
30	19	47	117	293	738
40	19	48	120	299	753
50	20	49	122	305	768

R-22 (KW)

Evap. Temp. (°C)	661.25-.16N	661.25-.4N	661.25-1.0N	661.25-2.5N	661.25-6.3N
-40	8.3	20	51	127	320
-35	8.6	21	53	132	333
-30	9.0	22	55	138	347
-20	9.7	24	60	149	376
-15	10	25	62	155	391
-10	10	26	65	161	406
-5	11	27	67	167	421
0	11	28	70	174	437
5	12	29	72	180	453
10	12	30	75	187	470

R-22 (TONS)

Evap. Temp. (°F)	661.25-.16N	661.25-.4N	661.25-1.0N	661.25-2.5N	661.25-6.3N
-40	2.5	6.1	15	38	95
-30	2.6	6.3	16	39	99
-20	2.7	6.6	17	41	104
-10	2.8	6.9	17	43	108
0	2.9	7.2	18	45	113
10	3.0	7.5	19	47	118
20	3.2	7.9	20	49	123
30	3.3	8.2	20	51	128
40	3.4	8.5	21	53	133
50	3.6	8.9	22	55	139

R-134a (KW)

Evap. Temp. (°C)	661.25-.16N	661.25-.4N	661.25-1.0N	661.25-2.5N	661.25-6.3N
-40	6.2	15	38	95	239
-35	6.6	16	40	101	254
-30	7.0	17	43	107	270
-20	7.9	19	48	121	304
-15	8.3	21	51	128	322
-10	8.8	22	54	135	340
-5	9.3	23	57	143	360
0	9.8	24	60	151	380
5	10	26	64	159	401
10	11	27	67	168	422

R-134a (TONS)

Evap. Temp. (°F)	661.25-.16N	661.25-.4N	661.25-1.0N	661.25-2.5N	661.25-6.3N
-40	1.9	4.6	11	29	72
-30	2.0	4.9	12	31	77
-20	2.1	5.2	13	33	82
-10	2.3	5.6	14	35	87
0	2.4	6.0	15	37	93
10	2.6	6.3	16	39	99
20	2.7	6.7	17	42	105
30	2.9	7.1	18	44	112
40	3.1	7.6	19	47	118
50	3.2	8.0	20	50	126

R717 capacities are based on 30°C (86°F) condensing temperature and 3.45 bar (50 psig) pressure drop across the valve

R22 and R134a capacities are based on 40°C (100°F) condensing temperature and 3.45 bar (50 psig) pressure drop across the valve.

Liquid Make Up Capacities (MVS)

High Pressure Receiver (HPR) to Intermediate

R-404a (KW)

Evap. Temp. (°C)	661.25-.16N	661.25-.4N	661.25-1.0N	661.25-2.5N	661.25-6.3N
-40	3.4	8.4	21	52	132
-35	3.7	9.1	23	57	143
-30	4.0	9.9	25	61	154
-20	4.6	11	29	71	179
-15	5.0	12	31	77	193
-10	5.3	13	33	82	207
-5	5.7	14	35	88	221
0	6.1	15	38	94	237
5	6.5	16	40	100	253
10	7.0	17	43	107	269

R-404a (TONS)

Evap. Temp. (°F)	661.25-.16N	661.25-.4N	661.25-1.0N	661.25-2.5N	661.25-6.3N
-40	1.1	2.6	6.5	16	41
-30	1.2	2.8	7.1	18	45
-20	1.3	3.1	7.7	19	48
-10	1.4	3.4	8.4	21	53
0	1.5	3.6	9.0	23	57
10	1.6	3.9	9.8	24	61
20	1.7	4.2	11	26	66
30	1.8	4.5	11	28	71
40	2.0	4.9	12	30	76
50	2.1	5.2	13	32	82

R-410a (KW)

Evap. Temp. (°C)	661.25-.16N	661.25-.4N	661.25-1.0N	661.25-2.5N	661.25-6.3N
-40	7.1	18	44	109	275
-35	7.4	18	46	114	288
-30	7.8	19	48	120	301
-20	8.5	21	52	130	328
-15	8.8	22	54	136	342
-10	9.2	23	57	141	356
-5	9.6	24	59	147	370
0	9.9	25	61	153	385
5	10	26	64	159	400
10	11	27	66	165	415

R-410a (TONS)

Evap. Temp. (°F)	661.25-.16N	661.25-.4N	661.25-1.0N	661.25-2.5N	661.25-6.3N
-40	2.1	5.3	13	33	83
-30	2.3	5.6	14	35	87
-20	2.4	5.8	15	36	91
-10	2.5	6.1	15	38	96
0	2.6	6.4	16	40	100
10	2.7	6.7	17	42	105
20	2.8	7.0	17	44	110
30	3.0	7.3	18	45	114
40	3.1	7.6	19	47	119
50	3.2	7.9	20	49	124

R-507a (KW)

Evap. Temp. (°C)	661.25-.16N	661.25-.4N	661.25-1.0N	661.25-2.5N	661.25-6.3N
-40	3.2	7.9	20	49	124
-35	3.5	8.6	22	54	135
-30	3.8	9.4	23	58	146
-20	4.4	11	27	68	171
-15	4.8	12	29	73	184
-10	5.1	13	31	79	198
-5	5.5	14	34	84	212
0	5.9	15	36	90	227
5	6.3	15	39	96	242
10	6.7	17	41	103	259

R-507a (TONS)

Evap. Temp. (°F)	661.25-.16N	661.25-.4N	661.25-1.0N	661.25-2.5N	661.25-6.3N
-40	1.0	2.5	6.2	15	39
-30	1.1	2.7	6.7	17	42
-20	1.2	2.9	7.3	18	46
-10	1.3	3.2	8.0	20	50
0	1.4	3.5	8.6	22	54
10	1.5	3.8	9.3	23	59
20	1.6	4.1	10	25	63
30	1.8	4.4	11	27	68
40	1.9	4.7	12	29	73
50	2.0	5.0	13	31	79

R404a, 410a, and R507a capacities are based on 40°C (100°F) condensing temperature and 3.45 bar (50 psig) pressure drop across the valve.

Liquid Level Transmitter (HBLT)

HBLT capacitive liquid level transmitters are used to measure liquid levels in refrigerant vessels. The HBLT comes factory calibrated for ammonia (for other refrigerants contact factory), so that it will cover 4 to 20 mA throughout the rod's whole measure range. 4 mA when the transmitter does not register liquid and 20 mA when the entire transmitter is surrounded by liquid. The 4 to 20 mA signal from the HBLT can be used in conjunction with a controller to control the liquid level.

Function

The electronic insert of the probe converts the measured change in capacitance of the liquid to a signal in proportion to the level (4 to 20 mA) making it possible to display, control and or regulate the liquid level when used in conjunction with a controller.

Specifications

Supply Voltage and Load	24V AC/DC ±10% (50/60Hz), 1.5W
Maximum Load Resistance	500 ohms
Electronic Connection	4-pole DIN plug
Liquid Temperature Range	-60°C - 80°C (-76°F - 176°F)
Ambient Temperature	-25°C - 50°C (-13°F - 122°F)
Maximum Rated Pressure (MRP)	100 bar (1450 psig)
Material: Thread	AISI 303 Stainless Steel
Reference Pipe	AISI 304 Stainless Steel
Inner Electrode	PTFE
Electronic Top Part	Coated Cast Aluminium

Features

- Plug and play: no calibration required when installed on ammonia systems
- Service friendly: electronic head and sensor tube can be separated without emptying the vessel
- Damping of output signal
- Improved calibration: range/signal output can be adapted to suit the actual application
- LED indication can be supplied with a LED Bargraph as option for indication of liquid level
- Enclosure IP65 classified

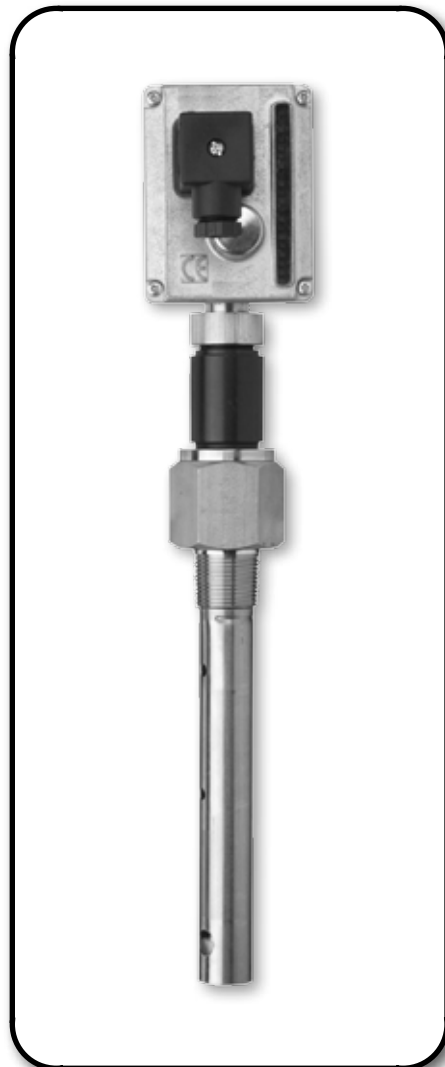

General Information

Probe Length	mm	152	203	305	389	488	587	762	889	1143	1397	1651	2159	2667	3048
	inch	6.0	8.0	12	15	19	23	30	35	45	55	65	85	105	120

Note

Liquid level transmitters less than 305 mm (12") are not compatible with halocarbons. For measuring liquid levels less than 305 mm (12") use the HBLC liquid level control sensor, see page [136](#) for more information.

Liquid Level Switches (HBSR, HBS01 & HBSC2)

HBS capacitive sensors are designed for industrial applications and long term function. These compact, cost effective switch designs, provide reliable and accurate detection of fluid levels in equipment such as liquid separators, high and low pressure receivers, economizers, oil coolers, oil pots, and compressors.

Switches operate according to the capacitive principle detecting presence of any kind of conductive or non-conductive liquid.

Specifications

Supply Voltage and Load	24V DC \pm 10%
Maximum Output Current	50mA
Output	NPN
Output Function	NO/NC
Electronic Connection	4-pole DIN plug
Temperature	Range:
HBSR	-50°C - 100°C (-58°F - 212°F)
HBS01	0°C - 85°C (32°F - 185°F)
HBSC2	-50°C - 100°C (-58°F - 212°F)
Ambient Temperature	-20°C - 50°C (-4°F - 122°F)
Maximum Rated Pressure (MRP):	
HBSR	100 bar (1450 psig)
HBS01	150 bar (2175 psig)
HBSC2	150 bar (2175 psig)
Material: Thread	AISI 303 Stainless Steel
Reference Pipe	AISI 304 Stainless Steel
Inner Electrode	PTFE or S.S. AISI 304
Electronic Head	GF BLK, Nylon 6, Glass Fiber
Connection:	
HBSR	3/4" NPT
HBS01	1/2" & 3/4" NPT
HBSC2	3/4" NPT

Features

- Plug and play: no calibration required when installed on ammonia systems
- Service friendly: electronic head and sensor tube can be separated without emptying the vessel
- Unaffected by foam, splashing and coating
- Resists high pressures and temperatures
- LED indication when liquid is present

HBSR

Switches on when conductive liquid is present. The switch distinguishes between oil and NH₃/HFC/brine and therefore ideal for automatic oil draining and emptying systems.

HBSC2

Switches on when liquid CO₂ is present. Ideal for high/low level indication, control alarm or CO₂ applications with pressures up to 170 bar (2465 psig)

HBS01

Switches on when oil is present. Ideal for oil management and oil level control as well as for compressor protection.

HBSR (top)

Refrigerant switch (NH₃, HFC, Brine)

HBS01 (middle)

Oil level switch



Note

Media temperatures below -30°C (-22°F) require the HBHE heating element.

Liquid Level Control Sensor (HBLC-V/C)

The liquid level control sensor, HBLC, is a stand-alone sensor with control function built-in to control refrigerant levels in high and low pressure condensers, evaporators and chillers. The HBLC sensor works in conjunction with a 4-20mA modulating control or solenoid valve.

This compact, cost effective sensor design, provides reliable and accurate detection of refrigerant levels in equipment.

Specifications

Supply Voltage and Load	24V DC \pm 10%
Analog Output	4 - 20mA
Maximum Current Consumption.....	30mA
Potential Free Output	On/Off, Max 1A (24W)
Output	PNP/NPN
Output Function	NO/NC
Cable Length	3m (118")
Electronic Connection	M12, 5 pin
Temperature Range	-50°C - 100°C (-58°F - 212°F)
Ambient Temperature	-20°C - 50°C (-4°F - 122°F)
Maximum Rated Pressure (MRP)	100 bar (1450 psig)
Material: Thread	AISI 303 Stainless Steel
Inner Electrode	PTFE or S.S. AISI 304
Electronic Head	GF BLK, Nylon 6, Glass Fiber
Connection:	$\frac{3}{4}$ " NPT



Features

- Suitable for ammonia and water/brine (HFC and CO₂ types are available on request)
- Stand alone microprocessor sensor with controller built in for automatic liquid management
- Easy setup and change of timer and alarm settings
- "Service Friendly" Split design for easy mounting, maintenance and remote programming without depressurization
- Unaffected by foam, splashing and coating
- Resists high pressures and temperatures
- LED indication for liquid, alarm and power
- Savings on installation, cost and time

LED Indication

Yellow - Liquid
 Green - Power
 Red - Alarm

Oil Level Control Sensor (HBOC-V/C)

HBOC is a stand-alone sensor and controller for easy and safe distribution of oil with built-in adjustable timer, alarm, alarm reset and compressor running signal. The oil level control sensor, in conjunction with a 24V DC solenoid valve, is designed to control oil levels in compressors and oil separator systems. This compact, cost effective sensor design, provides reliable and accurate detection of oil levels in equipment.

The oil carry over from compressors in multiple compressor parallel rack systems require proper oil management. The HBOC has been designed to control lubrication and prevent compressor break down.

Specifications

Supply Voltage and Load	24V DC \pm 10%
Maximum Current Consumption.....	30mA
Potential Free Output	On/Off, Max 1A (24W)
Output	PNP/NPN
Output Function	NO/NC
Cable Length	3m (118")
Electronic Connection	M12, 5 pin
Temperature Range	0°C - 85°C (32°F - 185°F)
Ambient Temperature	-20°C - 50°C (-4°F - 122°F)
Maximum Rated Pressure (MRP)	150 bar (2175 psig)
Material: Thread	AISI 303 Stainless Steel
Reference Pip	AISI 304 Stainless Steel
Inner Electrode	AISI 303 Stainless Steel
Electronic Head	GF BLK, Nylon 6, Glass Fiber
Connection:	$\frac{3}{4}$ " NPT

Features

- Stand alone microprocessor sensor with controller built in for automatic oil management
- Easy setup and change of timer and alarm settings
- "Service Friendly" Split design for easy mounting, maintenance and remote programming without depressurization
- Unaffected by foam, splashing and coating
- Resists high pressures and temperatures
- LED indication for oil, alarm and power
- Savings on installation, cost and time

LED Indication

Yellow - Oil
Green - Power
Red - Alarm



Note

Only DC supply for operating solenoid valves.

Refrigerant Float Switch (LLSS)

The LLSS refrigerant float switch is a mechanical float device which indicates a particular level of refrigerant in a vessel. It consists of a stainless steel welded chamber containing a float on the inside with a limit switch mounted on top. The chamber has a float-rod assembly inside with a metallic attractor located on the upper end of the rod. As the level in the system rises, the liquid fills the chamber causing the float ball to rise. The rising float with the attractor comes in close proximity of the magnet located inside the switch assembly. The magnet is mounted on a lever that operates a snap action switch. The switch can turn an electrical circuit on or off.

The float switch is used to open and close solenoid valves, to activate or de-activate electrical controls, to energize or de-energize magnetic starters for starting and stopping refrigerant liquid pumps and compressors, and as a safety device, to sound alarms and turn on lights when there is high or low liquid level. The electrical switch and operating mechanism are encapsulated within a UV resistant transparent housing.

Specifications

Specific Gravity Range 0.57 to 1.7
 Switch Ambient Temperature -45°C - 65°C (-150°F - 150°F)
 Tank Fluid Temperature -75°C - 65°C (-100°F - 150°F)
 Maximum Tank Rated Pressure (MRP) 31 bar (450 psig)
 Power 120VAC/240VAC/125VDC 10A/10A/0.5A

Features

- Suitable for Ammonia, R22, R-507, R-134a, and other common refrigerants
- Magnetically actuated switch
- UV resistant and transparent switch housing
- Stainless steel float chamber assembly
- Single pole double throw switch
- Float switch tank weighs 3.08 kg (6.8 lbs)
- Hermetically sealed
- All components in direct contact with refrigerant are stainless steel constructed
- Complies with Pressure Equipment Directive (PED) 97/23/EC (DIN connector only)
- Switch assembly is compatible with R/S liquid level models LL, LLS, and LLA



Liquid Level Sight Glass (SG1)

The Refrigerating Specialties liquid level sight glass SG1 provides a clear indication of liquid levels in industrial and commercial refrigeration systems.

As the refrigerant liquid level rises in the viewing area of the reflex lens, the color of the lens will turn dark. As the level decreases the color of the lens lightens.

Specifications

Temperature Range -50°C - 115°C (-60°F - 240°F)
Maximum Rated Pressure (MRP) 27 bar (400 psig)

Features

- Suitable for Ammonia, R-22, R-507, R-134a, and other common refrigerants
- Suitable for ASME Applications
- Reflex lens
- Frost shield available

See page [206](#) for dimensional information. Dimensions include frost shield.



Thermostatic Expansion Valves (TXV)

Ammonia Applications Only

Thermostatic expansion valves for ammonia applications require special design considerations due to the erosive effects of ammonia vapor. For this type of application, Refrigerating Specialties has developed the types D and A thermostatic expansion valves. Like other components of ammonia systems, the types D and A valves are made from steel and steel alloys.

With ammonia systems, the formation of flash vapor at the expansion valve port causes valve seat erosion or wire drawing to occur. This effect is further aggravated by high velocity ammonia mixed with dirt or scale passing through the port of the expansion valve. Fortunately, seat erosion can be minimized and valve life extended if the following steps are taken:

1. Maintain vapor-free liquid at the TXV inlet at all times
2. Maintain clean ammonia through effective filtration
3. Reduce the velocity of the ammonia through the TXV port by reducing the pressure drop across the port

Step 1: can be accomplished through proper system design. Liquid line vapor is prevented by adequately sizing liquid lines and providing sufficient subcooling.

Step 2: can be assured with the use of a Parker Replaceable Core Dryer. This filter dryer is an effective scale trap when used on ammonia systems. For further information on the use of this dryer with ammonia systems, refer to page [152](#) of this catalog.

Step 3: can be accomplished with the use of a removable discharge tube or the nozzle of a refrigerant distributor. These components reduce the velocity and pressure drop at the expansion valve port by introducing a restriction or added pressure drop in the valve outlet passage.

The removable discharge tube is threaded into the outlet of the type D valves, and the nominal 70.3, 105 and 176 kW (20, 30 and 50 ton) type A valves. The discharge tube is the principle difference between ammonia TXVs and TXVs used with other refrigerants.

The discharge tube in the outlet passage must be removed when the TXV is combined with a R/S Ammonia Distributor and Nozzle. If the discharge tube is not removed from the valve, the combination of the discharge tube and distributor nozzle may create an excessive pressure drop resulting in a substantial loss of TXV capacity. Refer pages [147](#) - [150](#) for further information on ammonia distributors.

The nominal 264 and 352 kW (75 and 100 ton) type A valves do not employ a discharge tube since their valve outlets are designed to serve as a secondary orifice to reduce pressure drop across the valve port.

Thermostatic Charges for Ammonia Valves

Thermostatic charges C and L are available for the Type D thermostatic expansion valve. The type L thermostatic charge is the only charge available for the type A valve.

The types C thermostatic charges provide operating advantages for systems that cycle in response to a suction pressure switch or thermostat. These charges are also recommended for systems using a small capacity compressor. The table below lists the recommended temperature range for each charge.



Cold storage plants often have large centralized ammonia systems consisting of many evaporators connected to one or more large compressors. This makes for fairly stable suction pressures. The R/S type L charge responds more quickly to changes in bulb temperature, allowing for a quicker pull-down of the conditioned space temperature. Therefore, for large ammonia systems consisting of multiple evaporators, the Type L charge is recommended.

Thermostatic Charge	Evaporator Temperature
C	4°C to -18°C (40°F to 0°F)
L	-29°C to 4°C (-20°F to 40°F)

For applications at evaporator temperature below -29°C (-20°F) consult R/S

Cold storage plants often have large centralized ammonia systems consisting of many evaporators connected to one or more large compressors. This makes for fairly stable suction pressures. The R/S type L charge responds more quickly to changes in bulb temperature, allowing for a quicker pull-down of the conditioned space temperature. Therefore, for large ammonia systems consisting of multiple evaporators, the type L charge is recommended.

TXVs

Thermostatic Expansion Valves (TXV)

Type D - FPT Flange Connections

The type D valve is an externally adjustable valve with a gray cast iron body. It is supplied with FPT connections (1/2" SW available). The thermostatic element is replaceable, and all internal parts are serviceable. An optional XD-074 (1/2" FPT) external inlet strainer may be ordered with this valve. The nominal 3.52 and 7.03 kW (1 and 2 ton) type D valves are identical, with the exception of their discharge tubes, as are the nominal 35.2 and 52.7 kW (10 and 15 ton) valves. One of these valves can be converted to the other by exchanging the discharge tubes.

Refrigerant distributors that will mate directly to this valve are listed below.

Note: The discharge tube must be removed when a refrigerant distributor is applied to the valve.

Specifications

Maximum Rated Pressure (MRP) 27.6 barg (400 psig)
 Outlet Connections "D" flange

Distributors

1130, 1132, 1133, 1180 (aluminum)
 1182 (aluminum)

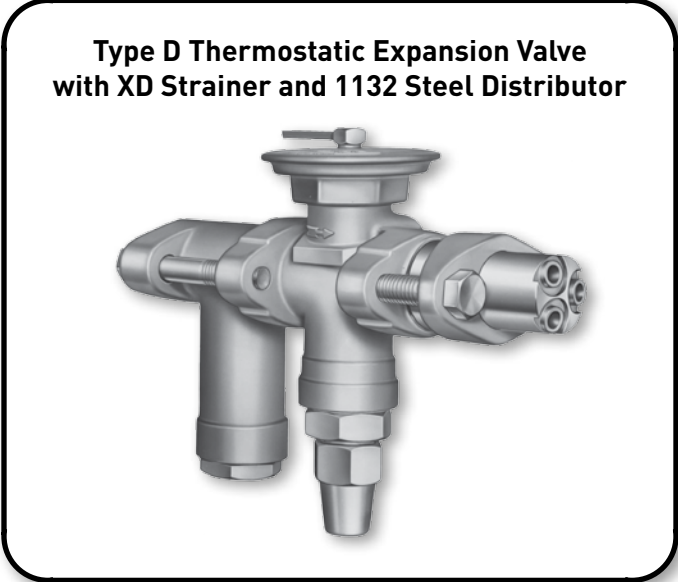

Specifications - Element Size No. 23, Gasket Joint

Type		Normal Capacity		Port Size (Inches)	Discharge Tube Orifice (Inches)	Thermostatic Charges Available	Std. Tubing (Length - Ft.)	Connections FPT & SW		Flange Ring Size OD X ID (Inches)	Maximum Design Pressure		Net Weight		Shipping Weight	
Internal Equalizer	External Equalizer 1/8" FPT							Inlet (inches)	Outlet (inches)		bar	psi	kg	lbs	kg	lbs
DA-1	DAE-1	3.52	1	1/16	1/32	C L Y764 Y779 Y1201	10* 20	1/4", 3/8", or 1/2"	1.12 x 0.75	29.3	425	3.6	8	4.1	9	
DA-2	DAE-2	7.03	2	1/16	1/16											
DA-5	DAE-5	17.6	5	7/64	5/64											
DA-10	DAE-10	35.2	10	3/16	7/64											
DA-15	DAE-15	52.7	15	3/16	5/32											

Bold* figures are standard and will be furnished unless other wise specified.

Material & Details of Construction

Valve Type	Body	Seat	Pin	Pin Carrier	Pushrod(s)	Type of Joints	Connection	Inlet Strainer
D	Gray Iron Casting	Stainless Steel or Steel Alloy	Tungsten Carbide	Stainless Steel	Stainless Steel	Gasket	FPT (1/2" SW only)	Removable Strainer Screen

Note: The DA to a DAE do not use the same body and are not inter changeable.
 Discharge tubes are only interchangeable when thermostatic expansion valves (TXV) have the same port size.

Thermostatic Expansion Valves (TXV)

Type A - FPT Flange Connections

The type A valve is an externally adjustable valve with a gray cast iron body and either FPT or socket weld flange connections. The thermostatic element is replaceable. An optional 8004 (1/2" FPT) or 8006 (3/4" FPT) strainer may be ordered with this valve.

The nominal 70.3 and 105 kW (20 and 30 ton) type A valves are identical with the exception of their discharge tubes. One of these valves can be converted to the other by exchanging their discharge tubes. The nominal 264 and 352 kW (75 and 100 ton) type A valves do not employ a discharge tube, nor are their outlets tapped to receive one.

Refrigerant distributors that will mate directly to this valve are listed below. Note: The discharge tube must be removed from the nominal 70.3, 105 and 176 kW (20, 30 and 50 ton) type A valves when a refrigerant distributor is applied.

Specifications

Maximum Rated Pressure (MRP) 27.6 barg (400 psig)
 Outlet Connections "A" flange

Distributors

1138, 1185 (aluminum)

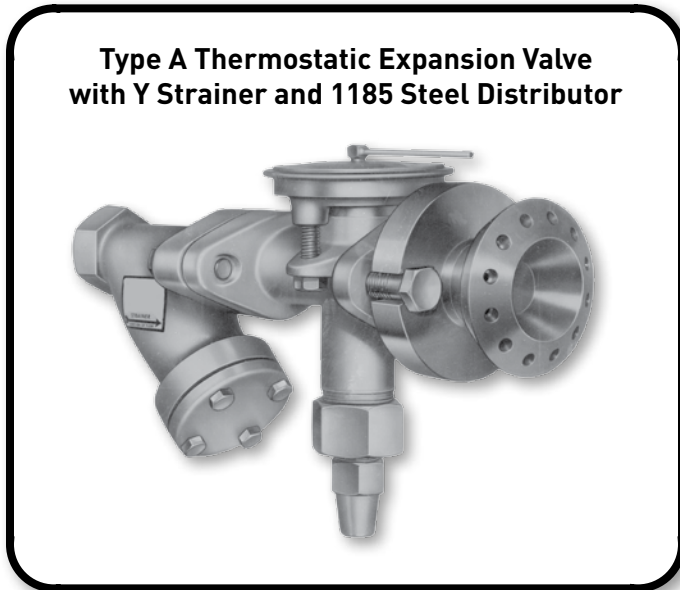

Specifications - Element Size No. 12, Gasket Joint

Type		Normal Capacity		Port Size (Inches)	Discharge Tube Orifice (Inches)	Thermostatic Charges Available	Std. Tubing (Length - Ft.)	Connections FPT & SW		Flange Ring Size OD X ID (Inches)	Maximum Design Pressure		Net Weight		Shipping Weight	
Internal Equalizer	External Equalizer 1/8" FPT							Inlet (inches)	Outlet (inches)		bar	psi	kg	lbs	kg	lbs
AA-20	AAE-20	70.3	20	5/16	1/8	L Y1182 Y830 Y832 Y1199	10* 20	1/2", 3/4, or 1		1.75 x 1.25	27.6	400	4.5	10	5.0	11
AA-30	AAE-30	105	30	5/16	5/32			3/4", or 1								
AA-50	AAE-50	176	50	3/8	3/16											
AA-75	AAE-75	264	75	3/8	—											
AA-100	AAE-100	352	100	7/16	—											

Bold* figures are standard and will be furnished unless other wise specified.

Material & Details of Construction

Valve Type	Body	Seat	Pin	Pin Carrier	Pushrod(s)	Type of Joints	Connection	Inlet Strainer
A	Gray Iron Casting	Stainless Steel or Steel Alloy	20 & 30 Ton: Tungsten Carbide 50, 75, & 100 Ton: Stainless Steel	Stainless Steel	Stainless Steel	Gasket	FPT or SW	Removable Strainer Screen

Note: The AA to a AAE do not use the same body and are not inter changeable.
 Discharge tubes are only interchangeable when thermostatic expansion valves (TXV) have the same port size.

TXVs

Thermostatic Expansion Valves (TXV) Capacities

These ratings are based on vapor free 30°C (86°F) liquid refrigerant entering the TXV, a maximum opening superheat of 7°F, and a standard factory air test setting.

AC and AL Thermostatic Charges 717 Capacities (KW)

Valve Type	Nominal Capacity	Port Size (inches)	Discharge Tube Size (inches)	Evaporator Temperature (°C)											
				4°				-7°				-15°			
				Pressure Drop Across Valve (bar)											
				5.5	6.9	8.3	9.7	6.9	8.3	9.7	11	6.9	8.3	9.7	11
D	3.52	1/16	1/32	3.80	4.25	4.64	5.03	3.59	3.94	4.25	4.54	2.99	3.27	3.52	3.76
	7.03	1/16	1/16	7.59	8.47	9.28	10.06	7.21	7.88	8.51	9.11	5.94	6.50	7.03	7.52
	17.6	7/64	5/64	19.0	21.2	23.2	25.1	18.0	19.7	21.3	22.7	14.9	16.3	17.6	18.8
	35.2	3/16	7/64	38.0	42.5	46.4	50.3	35.9	39.4	42.5	45.4	29.7	32.6	35.2	37.6
	52.7	3/16	5/32	57.0	63.6	69.6	75.2	54.1	59.1	64.0	68.2	44.7	48.9	52.7	56.3
A	70.3	5/16	1/8	67.9	75.9	83.0	89.7	66.1	72.4	78.1	83.3	59.4	65.0	70.3	75.2
	105	5/16	5/32	102	114	124	134	98.8	108	117	125	89.3	97.7	105	113
	176	3/8	3/16	169	190	207	224	165	181	195	208	149	163	176	188
	264	3/8	—	254	284	311	336	248	271	293	313	223	244	264	282
	352	7/16	—	339	380	415	447	330	362	390	418	297	326	352	376

AC and AL Thermostatic Charges 717 Capacities (TONS)

Valve Type	Nominal Capacity	Port Size (inches)	Discharge Tube Size (inches)	Evaporator Temperature (°F)											
				40°				20°				5°			
				Pressure Drop Across Valve (psi)											
				80	100	120	140	100	120	140	160	100	120	140	160
D	1	1/16	1/32	1.08	1.21	1.32	1.43	1.02	1.12	1.21	1.29	0.85	0.93	1.00	1.07
	2	1/16	1/16	2.16	2.41	2.64	2.86	2.05	2.24	2.42	2.59	1.69	1.85	2.00	2.14
	5	7/64	5/64	5.40	6.03	6.61	7.14	5.12	5.61	6.05	6.47	4.23	4.63	5.00	5.35
	10	3/16	7/64	10.8	12.1	13.2	14.3	10.2	11.2	12.1	12.9	8.45	9.26	10.0	10.7
	15	3/16	5/32	16.2	18.1	19.8	21.4	15.4	16.8	18.2	19.4	12.7	13.9	15.0	16.0
A	20	5/16	1/8	19.3	21.6	23.6	25.5	18.8	20.6	22.2	23.7	16.9	18.5	20.0	21.4
	30	5/16	5/32	28.9	32.3	35.4	38.2	28.1	30.8	33.3	35.6	25.4	27.8	30.0	32.1
	50	3/8	3/16	48.2	53.9	59.0	63.7	46.9	51.4	55.5	59.3	42.3	46.3	50.0	53.5
	75	3/8	—	72.3	80.8	88.5	95.6	70.4	77.1	83.3	89.0	63.4	69.4	75.0	80.2
	100	7/16	—	96.4	108	118	127	93.8	103	111	119	84.5	92.6	100	107

Correction Factor (CF) Liquid Temperature Entering TXV

Refrigerant	-18°C (0°F)	-12°C (10°F)	-7°C (20°F)	-1°C (30°F)	4°C (40°F)	10°C (50°F)	16°C (60°F)	21°C (70°F)	27°C (80°F)	30°C (86°C)	32°C (90°F)	38°C (100°F)
717	1.27	1.24	1.20	1.17	1.14	1.11	1.08	1.05	1.02	1.00	0.99	0.96

EXAMPLE:

Actual capacity of nominal 35.2 kW (10 ton) valve at -7°C (20°F) evaporator, 11 bar (160 psi) pressure drop and 16°C (60°F) liquid temperature

$$45.4 \text{ bar} \times 1.08 = 49.0 \text{ bar}$$

$$(12.9 \text{ tons} \times 1.08 = 13.9 \text{ tons})$$

These factors include corrections for liquid refrigerant density and net refrigerating effect and are based on an average evaporator temperature of -18°C (0°F). However, they may be used for any evaporator temperature from -29°C to 4°C (-20°F to 40°F) since the variation in the actual factors across this range is insignificant.

Thermostatic Expansion Valves (TXV) Capacities

These ratings are based on vapor free 30°C (86°F) liquid refrigerant entering the TXV, a maximum opening superheat of 7°F, and a standard factory air test setting.

AZ and AL Thermostatic Charges 717 Capacities (KW)

Valve Type	Nominal Capacity	Port Size (inches)	Discharge Tube Size (inches)	Evaporator Temperature (°C)							
				4°				-7°			
				Pressure Drop Across Valve (bar)							
				8.3	9.7	11.0	12.4	8.3	9.7	11.0	12.4
D	3.52	1/16	1/32	2.14	2.32	2.50	2.64	1.83	1.97	2.11	2.22
	7.03	1/16	1/16	3.73	4.01	4.29	4.54	3.13	3.38	3.62	3.83
	17.6	7/64	5/64	8.72	9.42	10.1	10.7	7.35	7.95	8.51	9.00
	35.2	3/16	7/64	18.4	19.9	21.3	22.6	15.5	16.8	18.0	19.1
	52.7	3/16	5/32	25.6	27.6	29.5	31.3	21.6	23.3	24.9	26.4
A	70.3	5/16	1/8	55.9	60.5	64.7	68.6	47.8	51.7	55.6	58.7
	105	5/16	5/32	84.0	90.7	97.0	103	72.1	77.7	83.0	88.3
	176	3/8	3/16	140	152	162	172	120	130	139	147
	264	3/8	—	210	227	243	257	180	194	208	220
	352	7/16	—	280	303	324	344	240	259	277	294

AZ and AL Thermostatic Charges 717 Capacities (TONS)

Valve Type	Nominal Capacity	Port Size (inches)	Discharge Tube Size (inches)	Evaporator Temperature (°F)							
				-10°				-20°			
				Pressure Drop Across Valve (psi)							
				120	140	160	180	120	140	160	180
D	1	1/16	1/32	0.61	0.66	0.71	0.75	0.52	0.56	0.60	0.63
	2	1/16	1/16	1.06	1.14	1.22	1.29	0.89	0.96	1.03	1.09
	5	7/64	5/64	2.48	2.68	2.87	3.04	2.09	2.26	2.42	2.56
	10	3/16	7/64	5.24	5.66	6.05	6.42	4.42	4.78	5.11	5.42
	15	3/16	5/32	7.27	7.85	8.39	8.90	6.13	6.62	7.08	7.51
A	20	5/16	1/8	15.9	17.2	18.4	19.5	13.6	14.7	15.8	16.7
	30	5/16	5/32	23.9	25.8	27.6	29.3	20.5	22.1	23.6	25.1
	50	3/8	3/16	39.9	43.1	46.0	48.8	34.1	36.9	39.4	41.8
	75	3/8	—	59.8	64.6	69.1	73.2	51.2	55.3	59.1	62.7
	100	7/16	—	79.7	86.1	92.1	97.7	68.2	73.7	78.8	83.6

Correction Factor (CF) Liquid Temperature Entering TXV

Refrigerant	-18°C (0°F)	-12°C (10°F)	-7°C (20°F)	-1°C (30°F)	4°C (40°F)	10°C (50°F)	16°C (60°F)	21°C (70°F)	27°C (80°F)	30°C (86°C)	32°C (90°F)	38°C (100°F)
717	1.27	1.24	1.20	1.17	1.14	1.11	1.08	1.05	1.02	1.00	0.99	0.96

EXAMPLE:

Actual capacity of nominal 35.2 kW (10 ton) valve at -23°C (-10°F) evaporator, 11 bar (160 psi) pressure drop and 16°C (60°F) liquid temperature

$$21.3 \text{ bar} \times 1.08 = 23.0 \text{ bar}$$

$$(6.05 \text{ tons} \times 1.08 = 6.53 \text{ tons})$$

These factors include corrections for liquid refrigerant density and net refrigerating effect and are based on an average evaporator temperature of -18°C (0°F). However, they may be used for any evaporator temperature from -29°C to 4°C (-20°F to 40°F) since the variation in the actual factors across this range is insignificant.

TXVs

Oil Cooling Thermostatic Charges

Estimated Bulb Temperature Control Range (°C)

Equalizer Pressure	Type D Valve Charges (°C)			Type A Valve Charges (°C)			
	bar	Y764	Y779	Y1201	Y1182	Y830	Y832
2.8	31 - 39	47 - 56	73 - 82	27 - 35	31 - 39	47 - 56	73 - 82
3.4	36 - 44	52 - 60	79 - 87	32 - 39	36 - 44	52 - 60	79 - 87
4.1	41 - 48	57 - 64	84 - 92	37 - 43	41 - 48	57 - 64	84 - 92
4.8	45 - 52	62 - 69	89 - 96	41 - 47	45 - 52	62 - 69	89 - 96
5.5	49 - 56	66 - 73	94 - 100	45 - 51	49 - 56	66 - 73	94 - 100

Estimated Bulb Temperature Control Range (°F)

Equalizer Pressure	Type D Valve Charges (°F)			Type A Valve Charges (°F)			
	psi	Y764	Y779	Y1201	Y1182	Y830	Y832
40	87 - 103	116 - 132	163 - 180	81 - 95	87 - 103	116 - 132	163 - 180
50	96 - 111	126 - 140	174 - 189	90 - 103	96 - 111	126 - 140	174 - 189
60	105 - 119	135 - 148	184 - 197	98 - 110	105 - 119	135 - 148	184 - 197
70	113 - 126	144 - 156	193 - 205	106 - 117	113 - 126	144 - 156	193 - 205
80	120 - 133	151 - 163	201 - 212	113 - 123	120 - 133	151 - 163	201 - 212

- ▶ Use 40°F evaporating temperature ratings
- ▶ Liquid temperature entering TXV
- ▶ Pressure drop across TXV
- ▶ Cooling load (compressor manufacturer)

Thermostatic Expansion Valves Selection Procedure

The following procedure should be used when selecting a R717 Ammonia TXV:

1. Determine the pressure drop across the valve

Subtract the evaporating pressure from the condensing pressure. The condensing pressure used in this calculation should be the minimum operating condensing pressure of the system. From this value, subtract all other pressure losses to obtain the net pressure drop across the valve. Be sure to consider all of the following possible sources of pressure drop: (1) friction losses through refrigeration lines including the evaporator and condenser; (2) pressure drop across liquid line accessories such as a solenoid valve and filter-drier; and (3) static pressure loss (gain) due to the vertical lift (drop) of the liquid line, see Table 1.

Table 1

Refrigerant	Vertical Lift				
	6.1 m (20 ft)	12.2 m (40 ft)	18.3 m (60 ft)	24.4 m (80 ft)	30.5 m (100 ft)
717 Ammonia	0.34 bar (5 psi)	0.69 bar (10 psi)	1.03 bar (15 psi)	1.38 bar (20 psi)	1.72 bar (25 psi)

It is not necessary to subtract the pressure drop across the refrigerant distributor when determining the pressure drop across a R/S Type D or type A valve with a nominal rating of 176 kW (50 tons) or less. These valves employ a discharge tube in the valve outlet passageway, and it should be removed when a distributor is connected to the valve. R/S distributors are normally selected to provide a 2.76 bar (40 psi) pressure drop at design load conditions for ammonia applications. Removing the discharge tube from the valve will compensate for this pressure drop.

2. Determine the liquid temperature of the refrigerant entering the valve

The R-717 Ammonia TXV rating tables on page 143 are based on a liquid temperature of 30°C (86°F). For other liquid temperatures, apply the correction factor given in the table.

The valve capacity should equal or slightly exceed the tonnage rating of the system.

3. Select valve from the rating tables

Select a valve based on the design evaporating temperature and the available pressure drop across the valve. If possible, the valve rating should equal or slightly exceed the design rating of the system. Be sure to apply the appropriate liquid temperature correction factor to

the valve ratings shown in the tables. Once the desired valve rating has been located, determine the nominal capacity of the valve from the second column of the table. On multiple evaporator systems, select each valve on the basis of individual evaporator capacity.

4. Determine if an external equalizer is required

The amount of pressure drop between the valve outlet and bulb location will determine if an external equalizer is required. The recommendations given in Table 1 are suitable for most field installed systems. Use an externally equalized valve when pressure drop between the valve outlet and bulb location exceeds values shown in Table 2. An externally equalized valve must be used on evaporators, which employ a refrigerant distributor.

Table 2

Refrigerant	Evaporator Temperature			
	4°C (40 °F)	-7°C (20 °F)	-18°C (0 °F)	-29°C (-20 °F)
717 Ammonia	0.21 bar (3 psi)	0.14 bar (2 psi)	0.10 bar (1.5 psi)	0.07 bar (1.0 psi)

When the thermostatic expansion valve is equipped with an external equalizer, it must be connected. Do not cap off the equalizer connection, as it will prevent the valve from operating properly.

5. Select the R/S Selective Thermostatic Charge

Select the charge according to the design evaporator temperature and the valve application. The subject of R-717 thermostatic charges is discussed on page 140.

Selection Example: Refrigerant 717

Application: Refrigeration, single evaporator system

Design evaporator temperature	-15°C (5°F)
Design condenser temperature	32°C (90°F)
Refrigerant liquid temperature	27°C (80°F)
Design evaporator capacity	17.6 kW (5 tons)

Available pressure drop across TXV

Condensing pressure	11.4 barg (166 psig)
Evaporator pressure	1.31 barg (19 psig)
Pressure Drop	10.1 bar (147 psi)

Liquid line and accessories loss	0.48 bar (7 psi)
⊙ Distributor and tubes loss	0 bar (0 psi)
Total Pressure Drop	9.65 bar (140 psi)

Refrigerant liquid correction factor

The DAE-5 has a valve capacity of: 17.6 x 1.02 = 17.93 kW (5.00 x 1.02 = 5.10 tons) at -15°C (5°F) evaporator temperature, 9.65 bar (140 psi) pressure drop, and 27°C (80°F) liquid temperature.

Thermostatic charge, see page 140: C

Selection: DAE-5-C

⊙ An externally equalized valve must be used on evaporators employing a refrigerant distributor due to the pressure drop created by the distributor. Pressure drop due to the distributor is not used in the calculation to determine pressure drop across the TXV since the valve's discharge tube will be removed. Refer to step 1 of the selection procedure.

TXVs

Refrigerant Distributors

Direct Expansion – Steel & Aluminum Models – Flange Connections

The distributor body is type ASTM A108 cold rolled steel. The nozzle is Type 303 stainless steel, and the dispersion cone in the distributor is made of Satellite.

Distributor tube connections are available for 3/16", 1/4", and 5/16" OD steel tubing. The ODF connections are trepanned to facilitate welding the joint. A 1/8" NPT connection is also available with Types 1130, 1133, and 1138 distributors.

Aluminum models – These distributors are designed for R-717 aluminum coils, and they are 6061-T6 aluminum. As with the steel distributors, the dispersion cone is Satellite, and the nozzle is stainless steel.

Distributor tube connections are available for 3/16", 1/4", and 5/16" OD aluminum tubing. Aluminum brazing techniques require more space between circuits than copper to brass brazing. As a result, the maximum number of circuits is less than for comparable brass models.

Applying Distributors to Thermostatic Expansion Valves

All type D and type A TXVs up to and including 176 kW (50 tons), employ a discharge tube. The discharge tube reduces refrigerant velocity across the valve port, preventing premature pin and seat erosion. When a distributor is used with these valves, the distributor nozzle performs the discharge tube's function. The discharge tube must then be removed from the valve to avoid excessive pressure drop.

Distributor performance is best obtained if the distributor is bolted directly to the TXV outlet. When it is not possible to bolt the TXV to the distributor, or if a shut off valve is installed between them, use a short, straight piece of pipe to connect the two. The pipe should not exceed two feet. It should be sized to maintain high refrigerant velocities. Elbows between the TXV and distributor are not recommended since they hinder proper distribution.

Ratings for Refrigerant 717 Distributors

Full load ratings are based on 2.07 bar (30 psi) nozzle, 0.69 bar (10 psi) tube pressure drop and 30°C (86°F) liquid temperature entering thermostatic expansion valve.

Distributor Tube Circuit Capacities - R717 (KW)

Distributor Tube OD (Inches)	Evaporator Temperature (°C)					
	4°	-7°	-15°	-23°	-29°	-34°
3/16	6.29	4.47	3.55	2.88	2.53	2.25
1/4	15.9	11.3	8.97	7.28	6.4	5.7
5/16	34.2	24.3	19.3	15.7	13.8	12.3
1/8 Pipe*	42.2	29.9	23.8	19.3	17	15.1

Distributor Tube Circuit Capacities - R717 (TONS)

Distributor Tube OD (Inches)	Evaporator Temperature (°F)					
	40°	20°	5°	-10°	-20°	-30°
3/16	1.79	1.27	1.01	0.82	0.72	0.64
1/4	4.52	3.2	2.55	2.07	1.82	1.62
5/16	9.73	6.9	5.5	4.46	3.93	3.49
1/8 Pipe*	12	8.5	6.77	5.5	4.84	4.3

* Schedule 40
Tons of Refrigeration – Tube Length 762 mm (30")
Distributor Nozzle Orifice Capacities for Ammonia at Various Evaporator Temperatures

Correction Factor (CF) - Liquid Temperature Entering TXV

Refrigerant	2°C (35°F)	7°C (45°F)	13°C (55°F)	18°C (65°F)	24°C (75°C)	30°C (86°F)	35°C (95°F)
717	2.95	2.15	1.58	1.33	1.17	1.00	0.85

To use the tables on page 148, knowing the total load in kW or tons and evaporator temperature, find nearest capacity in the table. On same horizontal line in extreme left column is the distributor nozzle orifice number to order. For example: 18.6kW (5.3 ton) load at minus -12° C (10°F) would require Nozzle Orifice Number 12A.

Distributors

Refrigerant Distributors

Nozzle Orifice 717 Capacities - R717 (KW)

Port Size	Evaporator Temperature (°F)					
	4 °	-7 °	-15 °	-23 °	-29 °	-34 °
1A	2.29	1.69	1.44	1.23	1.13	1.05
1½A	3.76	2.78	2.32	2.04	1.86	1.76
2A	4.99	3.69	3.09	2.67	2.46	2.29
2½A	7.14	5.27	4.43	3.83	3.52	3.31
3A	9.21	6.79	5.7	4.92	4.57	4.25
4A	10.6	7.81	6.54	5.66	5.24	4.89
5A	14.3	10.6	8.86	7.7	7.1	6.61
6A	17.4	12.9	10.8	9.35	8.61	8.05
8A	24	17.8	14.9	12.9	11.9	11.1
10A	28.5	21	17.7	15.3	14.1	13.1
12A	33.9	25	21	18.2	16.8	15.6
15A	46.1	34.1	28.6	24.8	22.9	21.3
18A	57.3	42.5	35.5	30.8	28.4	26.5
20A	61.2	45	38	32.7	30.2	28.2
25A	78.1	57.7	48.2	41.8	38.7	35.9
30A	103	75.9	63.6	55.2	51	47.5
35A	122	90.4	75.9	65.7	60.5	56.6
40A	138	102	85.4	73.8	68.2	63.6
50A	173	129	108	93.5	86.1	80.5

Nozzle Orifice 717 Capacities - R717 (TONS)

Port Size	Evaporator Temperature (°F)					
	40 °	20 °	5 °	-10 °	-20 °	-30 °
1A	0.65	0.48	0.41	0.35	0.32	0.3
1½A	1.07	0.79	0.66	0.58	0.53	0.5
2A	1.42	1.05	0.88	0.76	0.7	0.65
2½A	2.03	1.5	1.26	1.09	1	0.94
3A	2.62	1.93	1.62	1.4	1.3	1.21
4A	3.01	2.22	1.86	1.61	1.49	1.39
5A	4.07	3.01	2.52	2.19	2.02	1.88
6A	4.95	3.66	3.07	2.66	2.45	2.29
8A	6.83	5.05	4.23	3.67	3.38	3.15
10A	8.1	5.98	5.02	4.35	4.01	3.74
12A	9.64	7.12	5.98	5.17	4.77	4.45
15A	13.1	9.69	8.13	7.04	6.5	6.06
18A	16.3	12.1	10.1	8.77	8.09	7.55
20A	17.4	12.8	10.8	9.31	8.59	8.01
25A	22.2	16.4	13.7	11.9	11	10.2
30A	29.2	21.6	18.1	15.7	14.5	13.5
35A	34.8	25.7	21.6	18.7	17.2	16.1
40A	39.2	29	24.3	21	19.4	18.1
50A	49.2	36.6	30.7	26.6	24.5	22.9

Ratings based on 30°C (86°F) liquid entering TXV, 2.07 bar (30 psi) ΔP across nozzle, 0.69 bar (10 psi) ΔP across distributor tubes, 762 mm (30") tube length.

For information on applications and capacities at evaporator temperatures below -34°C (-30°F) consult R/S.

Note: For direct expansion application with liquid temperatures lower than tabulated values or for flooded liquid recirculation systems – contact R/S.

Refrigerant Distributors

Two 7/16" – 14 THD 2" long bolts connect these distributors to the Type D valve.

The types 1130 distributors do not require a companion flange. These distributors bolt directly to the type D valve using two 7/16" – 14 THD 1 1/2" bolts.

All distributors used with the type D valve require flange gasket P/N 207658.

The type 1138 distributors have a male flange ring that bolts directly to the type A valve.

Two 1/2" – 13 THD 1 3/4" long bolts connect these distributors to the type A valve.

All distributors used with type A valve require flange gasket P/N 207657.

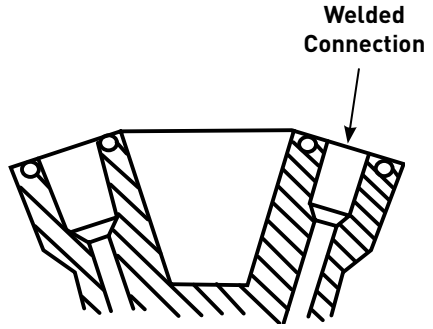

Weld connection available only

General Information

No. Circuits & Tubing Sizes Available	Nozzle Orifice Numbers Available	Nozzle & Retainer Ring Size	Distributor
Type 1130 Steel		<p>G</p> <p>Used in combination with R/S Valve Type DAE and XD Strainer or XD Strainer, with Spacer Part No. 207652</p>	
2 to 10 - 3/16" ODF Welded	<p>Net Weight Approximately 1 lb., 10 Oz.</p> <p>1A thru 30A</p>		
4 to 10 - 1/4" ODF Welded			
2 to 6 - 5/16" ODF Welded			
Type 1138 Steel		<p>C</p> <p>Used in combination with R/S Valve Type AAE and 8004 Strainer or AAE, 8004 Strainer or 8004 Strainer with Spacer Part No. 207653</p>	
11 to 19 - 3/16" ODF Welded	<p>Net Weight Approximately 3 lb., 6 Oz.</p> <p>5A thru 50A</p>		
6 to 14 - 1/4" ODF Welded			
7 to 12 - 5/16" ODF Welded			

Distributors

Refrigerant Distributors

Refrigerant Distributor with Auxiliary Side Connection

The type 1133 distributor bolts directly to the type D valve. This distributor features a side connection for hot gas bypass, hot gas defrost, or reverse cycle defrost applications.

Two 7/16" - 13 THD 2" long bolts connect these distributors to the type D valve.

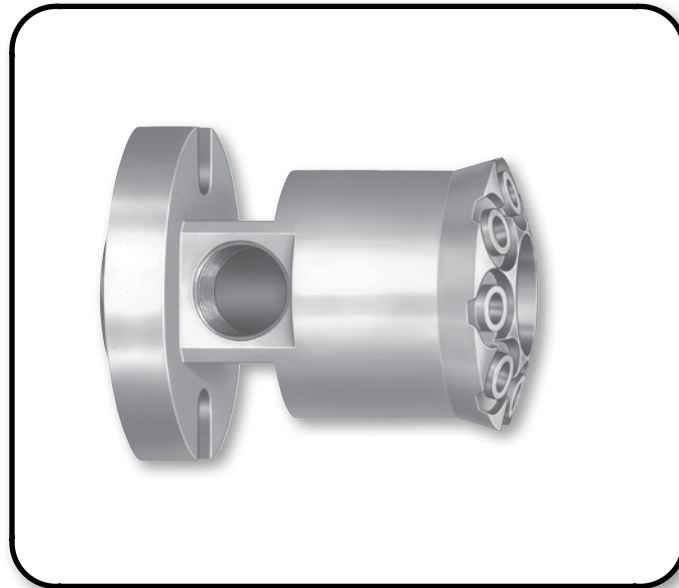

General Information

No. Circuits & Tubing Sizes Available	Nozzle Orifice Numbers Available	Side Connections		Nozzle & Retainer Ring Size
		Number	Size	
Type 1133 Steel	Net Weight - Approximately 2 lb., 10 Oz.			
2 to 10 - 3/16" ODF Welded	1A thru 30A	1	3/8" or 1/2" FPT	G Used in combination with R/S Valve Type DAE and XD Strainer or DAE, XD Strainer or XD Strainer with Spacer Part No. 207652
2 to 8 - 1/4" ODF Welded				
2 to 6 - 5/16" ODF Welded				
2 to 6 - 1/8" NPT				

Distributors

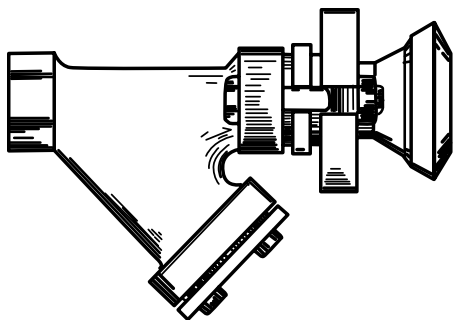

8004 Strainer
Adaptor - Spacer 207653, 1138 Steel or 1185 Aluminum Distributor

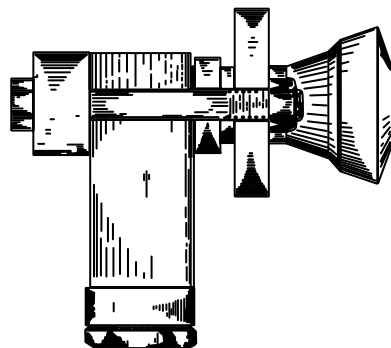

XD Strainer
Adaptor - Spacer 207652, 1130 & 1133 Steel or 1182 Aluminum Distributor

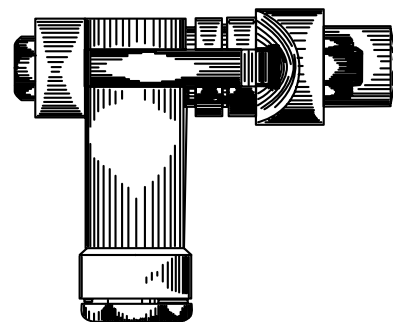

XD Strainer Adaptor - Spacer 207652, Steel Flange No. 207650, 1132 Steel or 1180 Aluminum Distributor

XJH and XOP Solenoid Valves

Type XJH and XOF solenoid valves are of the direct acting type and are designed for small capacity ammonia/oil service. Both of these valves may be mounted horizontally, on their side or in a vertical line.



General Information

Type	Connection (Inches)	Port Size (Inches)	MOPD		Nominal Liquid Capacities kW (Tons) of Refrigeration										Standard Coil Ratings	
					Ammonia											
			AC		Pressure Drop											
			bar	psi	0.07 bar (1 psi)	0.14 bar (2 psi)	0.21 bar (3 psi)	0.28 bar (4 psi)	0.34 bar (5 psi)	Volts / Cycles	Watts					
XJH	1/4" NPT Female	0.109	17.2	250	13.75	3.91	19.48	5.54	23.87	6.79	27.60	7.85	30.87	8.78	24 / 50-60 120 / 50-60 208 / 50-60 240 / 50-60 Dual 120-240 / 60	10
XOF	3/8" NPT Female															

- ▶ Safe working pressure 20.7bar (300 psi).
- ▶ Dual voltage 4-wire coils, 120-240/60 are available at slight additional cost. For other voltages and cycles, consult R/S.
- ▶ Available with conduit boss or junction box at no extra charge.

Replaceable Core Filter Dryers

Ammonia Parker Replaceable Core Filter Dryers

The molded porous Replaceable Core Filter Dryer effectively removes scale and other fine particles – keeping the system clean – and prolonging the life of all moving parts.

Small amounts of water are not considered a problem in ammonia systems. Therefore, the “drier” function of the desiccant core is not normally required.

The type C-413-P is a sealed model filter-drier. All of the other models shown at the right are replaceable core types. Use the RC-4864 or RC-10098 replaceable cores for excellent filtration ability.

Note: Do not use RPE-48-BD and RPE-100 Filter Elements on ammonia systems.



Specifications

Temperature Range -46°C to 116°C (-50°F to 240°F)
 Maximum Rated Pressure (MRP) 34.5 barg (500 psig)

Replaceable Cores

Cores for replacement core type filter-driers are molded of exactly the same desiccants that are used in the popular sealed model filter-driers.

Cores are individually packed in metal cans, fully activated, and hermetically sealed against moisture and dirt.

The method of mounting the cores on the end plate by means of tie rods makes them very easy to install and remove.

Replaceable core filter dryers with pipe connections are supplied with an envelope containing 5 end plate gaskets. When replacement of end plate gasket is required, use one gasket from the envelope.

General Information

Type	Connections (Inches)	No. of Cores	Core Part No.	Volume of Desiccant (Cu. In.)	Mounting Brackets
C-484-P	½ FPT	1	RC-4864	48	A-685
C-966-P	¾ FPT	2		96	
C-1448-P	1 FPT	3		144	
C-19212-P	1½ FPT	4		192	
C-40016-P	2 FPT	4	RC-1009-8	400	A-175-2

Replaceable Cores

Type	Fitting Size (Inches)	Selection Recommendations		Ratings at AHRI Standard Conditions				Replaceable Core Type and Quantity Required	Core Qty
				Water Capacity Drops at 60 PPM		Refrigerant Flow Capacity 0.07bar (1 psi) ΔP			
		kW	tons	25°C (75°F)	50°C (125°F)	kW	tons		
C-413-P	¾ FPT	70.3	20	—	—	203.9	58	—	—
C-484-P	½ FPT	141	40	934	301	253	72	RC-4864	1
C-966-P	¾ FPT	352.0	100	1868	602	665.0	189	RC-4864	2
C-1448-P	1 FPT	527	150	2802	903	1016.0	289	RC-4864	3
C-19212-P	1½ FPT	1055	300	3736	1204	1674	476	RC-4864	4
C-40016-P	2 FPT	1582	450	7621	2458	2447.0	696	RC-10098	4

Strainers

“XD” Type Strainers

Type XD Strainer is for use with Ammonia and other liquids where a steel construction is suitable. May be used with companion flange or can be bolted directly to type D thermostatic expansion valves.

Semi-cast steel body with FPT inlet and flanged outlet connections. Strainer screen is stainless steel with a seal plug for screen removal. Complete unit is zinc plated and painted.

Specifications

Maximum Rated Pressure (MRP) 34.5 barg (500 psig)



General Information

Type	Connections (Inches)		Screen		Mesh Size
	Inlet	Outlet	Area (sq.i.n.)	Part No.	
XD 074	½ FPT	Flange	6.6	635-3	100

Strainers are supplied with female companion flange. Strainers can be ordered without the flange.

“Y” Type Strainers

Type 8000 Strainer is used primarily for Refrigerant 717 Ammonia, but can also be used for halocarbon refrigerants (R-22, R-134a, and R-404A) and other liquids where a steel construction is applicable. FPT inlet, standard two bolt York flange outlet connections. Types 8004 and 8006 strainers can be bolted direct to the inlet of type A thermostatic expansion valves on ammonia applications. The unit is zinc plated.

Type 9000 Strainers for large Refrigerant 717 Ammonia installations are also adaptable to halocarbon refrigerant (R-22, R-134a, and R-404A) applications, and other liquids where steel construction is suitable. The strainer is zinc plated. FPT inlet, standard four bolt York flange outlet connections.

Specifications

Maximum Rated Pressure (MRP)

8000 series 34.5 barg (500 psig)
 9000 series 27.6 barg (400 psig)



General Information

Type	Connections (Inches)	Screen		Mesh Size
		Area (sq. in.)	Part No.	
8004	½ FPT*	15	4097-3	80
8006	¾ FPT *			
9008	1 FPT**	23	4110-3	60
9010	1¼ FPT**			

* Strainers are supplied without companion flange. Female companion flange, bolts, and gasket can be supplied when ordered.

** Strainers are supplied without companion flange. Male companion flange, bolts, and gasket can be supplied when ordered.

Level Master Control

Application and Installation

The R/S Level-Master Control is a positive liquid level control device suitable for application to all flooded evaporators.

Description and Operation

The LMC is a standard thermostatic expansion valve equipped with a Level-Master Element. The combination provides a simple, economical, and highly effective liquid level control. The bulb of the conventional thermostatic element has been modified to an insert type of bulb that incorporates a low wattage heater. A 15-watt heater is supplied as standard.

The insert bulb is installed in the accumulator or surge drum at the point of the desired liquid level. As the level at the insert bulb drops, the electrically added heat increases the pressure within the thermostatic element and opens the valve. As the liquid level at the bulb rises, the electrical input is balanced by the heat transfer from the bulb to the liquid refrigerant and the LMC either modulates or eventually shuts off. The evaporator pressure and spring assist in providing a positive closure.

Installation – General

The Level-Master Control is applicable to any system that has been specifically designed for flooded operation.

R/S is not responsible for system design and, therefore, is not liable for any damage arising from faulty design or improper piping, or for misapplication of its products. Figures 2 through 4 are piping schematics only to illustrate possible methods of applying the LMC valves.

If these valves are applied in any manner other than as described in this bulletin, the R/S warranty is void. Actual system piping must be done to protect the compressor at all times. This includes protection against overheating, slugging with liquid refrigerant, and trapping of oil in various locations. R/S recommends that recognized piping references, such as equipment manufacturers' literature and the ASHRAE Guide and Data Book, be consulted for assistance with this subject.

The valve is usually connected to feed into the surge drum above the liquid level. It can also feed into the liquid leg or coil header.

The insert bulb can be installed directly into the shell, surge drum or liquid leg on new or existing installations. Existing float systems can be easily converted by installing the LMC insert bulb in the float chamber.

The Level-Master Control may be installed at any ambient temperature. The element is protected against excessive temperature, created by the heater, by a thermostatic switch that is an integral part of the heater assembly.

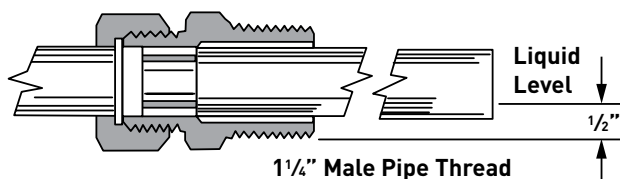

Figure 1: Horizontal Position

Installation – Insert Bulb

The insert bulb should be installed at the point where the desired liquid level is to be maintained. The bulb must be in contact with the refrigerant, i.e., NOT installed in a well. If the insert bulb is projected directly into the surge drum, it should be shielded to prevent the possibility of splash from either the valve feed or the return from the coil. While generally installed in a horizontal position, see Figure 1, it will operate effectively at any angle or vertical position.

Minor adjustments in liquid level can be made with the adjusting stem provided on the expansion valve. The insert bulb assembly is provided with a lock ring and gasket joint so that the bulb may be removed without breaking the pipe joint.

Installation – Electrical Connections

The heater is provided with a two-wire neoprene covered cord two feet in length. It runs through a moisture-proof grommet and a 1/2" male conduit connection affixed to the insert bulb assembly, see Figure 2.

The heater circuit must be interrupted when refrigeration is not required and the compressor is cycled off. This will prevent shortening the life of the heater thermostat. To accomplish this, the heater is wired in parallel (on the compressor side) with the control or power relay, the holding coil of the compressor magnetic starter, or the liquid line solenoid valve.

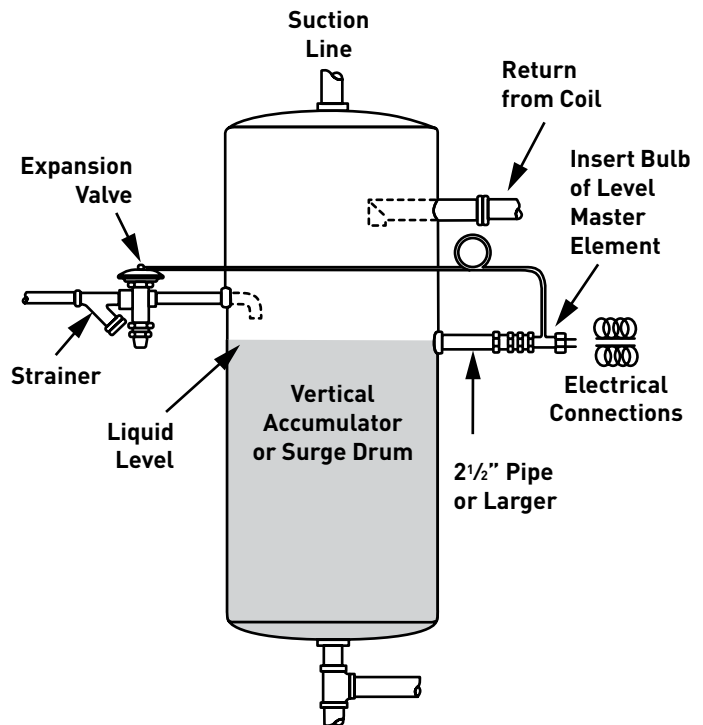

Figure 2: Typical Installation



Level Master Control Design Precautions

Hand Valves

On installations where the valve is isolated from the surge drum by a hand valve, and a two to three pound pressure drop from the valve outlet to the bulb location is likely, we recommend that an externally equalized valve be used. (See ordering instructions.)

Oil Return

General – All reciprocating compressors will allow some oil to pass into the discharge line along with the discharge gas. Mechanical oil separators are used extensively; however, they are never completely effective. The untrapped oil passes through the condenser, liquid line, expansion device and finally into the evaporator.

In a properly designed direct expansion system, the refrigerant velocity in the evaporator tubes and in the suction line is sufficiently high to ensure a continuous return of oil to the compressor crankcase. But, this is not characteristic of flooded systems. Here, we purposely design the surge drum for a relatively low vapor velocity to prevent entrainment of liquid refrigerant droplets and consequent carryover into the suction line. This design criterion also prevents the return of any oil from the low side in the normal manner.

And if oil is allowed to concentrate at the insert bulb location of the R/S Level-Master Control, overfeeding with possible floodback can occur. The tendency to overfeed is due to the fact that the oil does not convey the heat from the low wattage heater element away from the bulb as rapidly as does pure liquid refrigerant. The bulb pressure is higher than normal and the valve remains in the open or partially open position.

Oil and Ammonia Systems

Liquid ammonia and oil are immiscible for all practical purposes. And since the density of oil is greater than that of ammonia, it will fall to the bottom of any vessel containing such a mixture, if the mixture is relatively placid. Therefore, the removal of oil from an ammonia system is a comparatively simple task. Generally, on systems equipped

with a surge drum, the liquid leg is extended downward below the point where the liquid is fed off to the evaporator and a drain valve is provided to allow periodic manual draining as shown in Figure 3.

For flooded chillers that do not use a surge drum, a sump with a drain valve is usually provided at the bottom of the chiller shell.

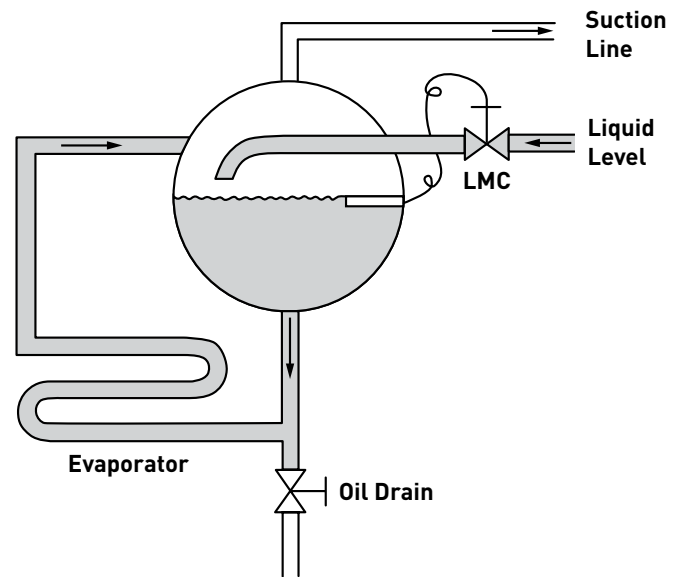

Figure 3: Surge Drum

The above methods are quite satisfactory, except possibly on some low temperature systems. Here, the drain leg or sump generally has to be warmed prior to attempting to draw off the oil since the trapped oil becomes quite viscous at lower temperatures. If oil is not drained from a flooded ammonia system, a reduction in the evaporator heat transfer rate can occur due to an increase in the refrigerant film

resistance. Difficulty in maintaining the proper liquid level with any type of flooded control can also be expected.

With a float valve, you can expect the liquid level in the evaporator to increase with high concentration of oil in a remote float chamber.

If a R/S Level-Master Control is used with the insert bulb installed in a remote chamber, oil concentration at the bulb can cause overfeeding with possible floodback. The lower or liquid balance line must be free of traps and be free draining into the surge drum or chiller as shown in Figure 4. The oil drain leg or sump must be located at the lowest point in the low side.

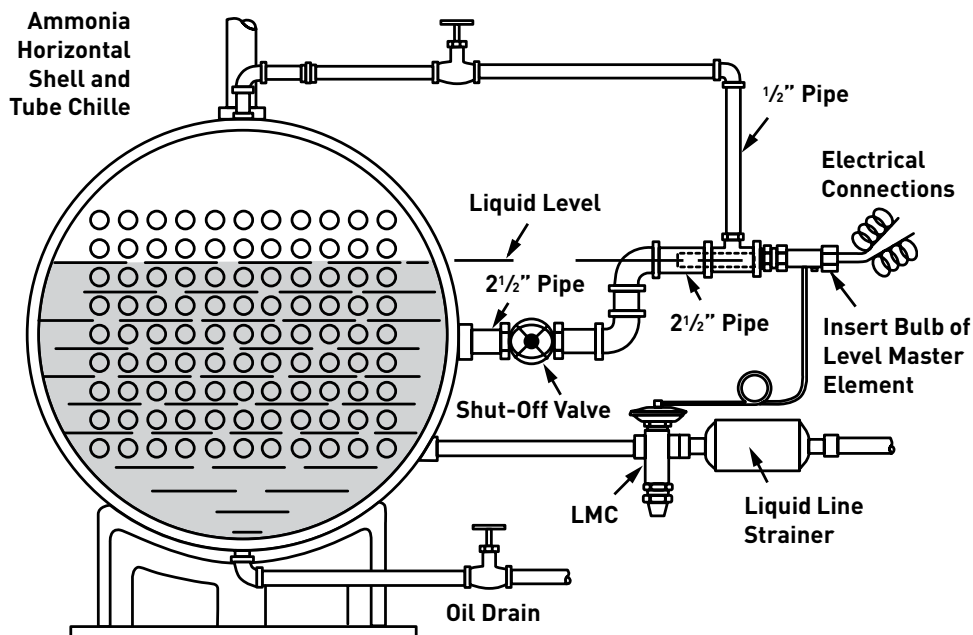

Figure 4: Typical Installation

Level Master Control

Capacity in Tons of Refrigeration

These ratings are based on vapor free (subcooled) liquid refrigerant entering the expansion valve (30°C/86°F for Refrigerant 717) and standard factory setting. Because of the artificial superheat provided by the electric heater, the Level-Master will have a greater capacity than a conventional thermostatic expansion valve. For selections for other refrigerants, contact Refrigerating Specialties.

Electrical Specifications

15/24-watt - 24v, 120v or 240v any frequency AC or DC.

Watts	Voltage	Amps
15	24	0.125
	120	0.625
	240	0.063
25	24	1.04
	120	0.20
	240	0.104

Standard Tubing Length

3.05 m (10 ft) – Other lengths in integrals of 1.54 m (5 ft) available on special order.

Replacement Parts

Internal parts kits – Same as standard thermostatic expansion valves. Specify valve type and port size.

Heater Element Assembly

Consists of heater element, lead wire, protective thermostatic switch, and moisture proof seal.

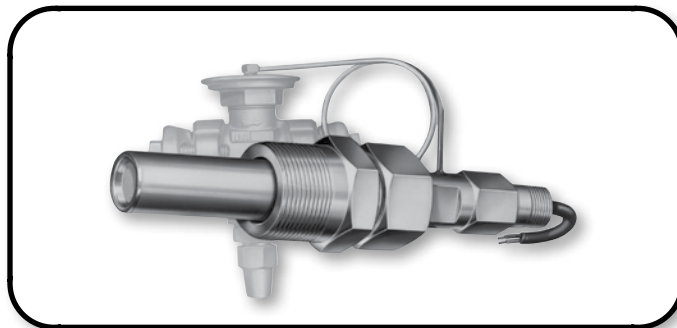

General Information

Complete Control Valve & Element		Element Only	Discharge Tube (Inches)	Standard Connections (Inches) Sizes shown in BOLD figures will be furnished unless otherwise specified	
Internal Equalizer	¹ External Equalizer			Inlet	Outlet
LMC-DA-1	LMC-DAE-1	LMC 23AL	1/32	1/4, 3/8, or 1/2 FPT	
LMC-DA-2	LMC-DAE-2		1/16		
LMC-DA-5	LMC-DAE-5		5/64		
LMC-DA-10	LMC-DAE-10		7/64		
LMC-DA-15	LMC-DAE-15		5/32		
LMC-AA-20	LMC-AAE-20	LMC 12AL	1/8	1/2 or 3/4 FPT	
LMC-AA-30	LMC-AAE-30		5/32		
LMC-AA-50	LMC-AAE-50		3/16		
LMC-AA-75	LMC-AAE-75		—	3/4 FPT	
LMC-AA-100	LMC-AAE-100		—		

¹ Standard External Equalizer Connection (1/8" FPT) available when specified.

Level Master Control Capacities and Selections

LMC R717 Capacities (kW)

Valve Type	Nominal Capacity	Evaporator Temperature (°C)																			
		4° to -18°					-23°					-29°					-40°				
		Pressure Drop Across Valve (bar)																			
		5.5	6.9	8.3	9.7	11	6.9	8.3	9.7	11	12	6.9	8.3	9.7	11	12	6.9	8.3	9.7	11	12
D	1	3.31	3.73	4.08	4.40	4.71	3.45	3.76	4.04	4.32	4.61	3.02	3.31	3.55	3.80	4.04	2.07	2.29	2.46	2.64	2.81
	2	9.46	10.6	11.6	12.5	13.4	9.74	10.7	11.5	12.3	13.0	8.58	9.39	10.1	10.8	11.5	5.91	6.50	7.00	7.49	7.95
	5	21.4	23.9	26.2	28.3	30.2	22.0	24.1	26.1	27.8	29.5	19.4	21.2	22.9	24.5	26.0	13.4	14.7	15.9	16.9	18.0
	10	38.7	43.2	47.5	51.3	54.8	39.7	43.6	47.1	50.6	53.4	35.0	38.3	41.5	44.3	47.1	24.2	26.6	28.8	30.7	32.6
	15	52.7	59.1	64.7	70.0	74.9	54.1	59.4	64.3	68.9	73.1	47.8	52.4	56.6	60.5	64.3	33.1	36.2	39.0	41.8	44.3
A	20	62.6	69.6	76.6	82.6	88.3	64.0	70.3	75.9	81.2	86.1	56.3	61.9	66.8	71.4	75.9	39.0	42.9	46.4	49.2	52.4
	30	105	118	129	140	149	109	119	128	137	146	85.1	105	113	121	128	66.1	72.4	78.1	83.3	88.6
	50	150	168	184	199	212	154	169	183	195	207	136	149	161	172	182	94	103	111	119	126
	75	264	295	323	349	373	272	297	321	343	362	239	262	283	302	320	165	181	196	209	222
	100	373	415	457	492	527	380	422	454	485	513	336	369	397	429	454	232	256	276	295	313

LMC R717 Capacities (TONS)

Valve Type	Nominal Capacity	Evaporator Temperature (°F)																			
		40° to 0°					-10°					-20°					-40°				
		Pressure Drop Across Valve (psi)																			
		80	100	120	140	160	100	120	140	160	180	100	120	140	160	180	100	120	140	160	180
D	1	0.94	1.06	1.16	1.25	1.34	0.98	1.07	1.15	1.23	1.31	0.86	0.94	1.01	1.08	1.15	0.59	0.65	0.70	0.75	0.80
	2	2.69	3.01	3.30	3.56	3.80	2.77	3.04	3.28	3.50	3.71	2.44	2.67	2.88	3.08	3.26	1.68	1.85	1.99	2.13	2.26
	5	6.08	6.80	7.45	8.05	8.60	6.26	6.85	7.41	7.91	8.39	5.51	6.03	6.52	6.97	7.39	3.81	4.17	4.51	4.82	5.11
	10	11.0	12.3	13.5	14.6	15.6	11.3	12.4	13.4	14.4	15.2	9.96	10.9	11.8	12.6	13.4	6.89	7.56	8.18	8.74	9.26
	15	15.0	16.8	18.4	19.9	21.3	15.4	16.9	18.3	19.6	20.8	13.6	14.9	16.1	17.2	18.3	9.41	10.3	11.1	11.9	12.6
A	20	17.8	19.8	21.8	23.5	25.1	18.2	20.0	21.6	23.1	24.5	16.0	17.6	19.0	20.3	21.6	11.1	12.2	13.2	14.0	14.9
	30	30.0	33.6	36.8	39.7	42.4	30.9	33.8	36.5	39.0	41.4	24.2	29.8	32.2	34.3	36.4	18.8	20.6	22.2	23.7	25.2
	50	42.7	47.7	52.3	56.5	60.4	43.9	48.1	52.0	55.6	58.9	38.6	42.4	45.8	48.9	51.9	26.7	29.3	31.6	33.8	35.9
	75	75.1	84.0	92.0	99.4	106	77.3	84.6	91.4	97.5	103	68.0	74.5	80.5	85.9	91.1	47.0	51.5	55.7	59.4	63.0
	100	106	118	130	140	150	108	120	129	138	146	95.6	105	113	122	129	66.1	72.8	78.4	84.0	89.1

These factors include corrections for liquid refrigerant density and net refrigerating effect, and are based on an average evaporating temperature of -18°C (0°F). However, they may be used for any evaporator temperature from -40°C to 4°C (-40°F to 40°F) since the variation in the actual factors across this range is insignificant.

Correction Factor (CF) Liquid Temperature Entering TXV

Refrigerant	-18°C (0°F)	-12°C (10°F)	-7°C (20°F)	-1°C (30°F)	4°C (40°F)	10°C (50°F)	16°C (60°F)	21°C (70°F)	27°C (80°F)	30°C (86°C)	32°C (90°F)	38°C (100°F)
717	1.27	1.24	1.20	1.17	1.14	1.11	1.08	1.05	1.02	1.00	0.99	0.96

EXAMPLE:

At -29°C (-20°F) evaporator, 11 bar (160 psi) pressure drop and 10°C (50°F) liquid temperature, the capacity of an LMC-DA-10 (for ammonia) is:

$$44.3 \text{ bar} \times 1.11 = 49.2 \text{ bar}$$

$$(12.6 \text{ tons} \times 1.11 = 14.0 \text{ tons})$$

Sight Glass (SA K87 & SA K90)

Designed to be closed coupled with TXV valves the SA series sight glass offers a sight glass with flange connections for use on ammonia systems. By using the sight glass, one can be assured that solid liquid enters the thermostatic expansion valve. The sight glass can be used to diagnose system problems, and thus eliminate flash gas in the liquid entering the TXV.

These sight glasses are specifically designed for ammonia system use. The glass is fused into a steel body, which is then cadmium plated. Two sizes of flange connections permit attaching the sight glass into the system conveniently. The smaller flange size will mate with R/S type DA thermostatic expansion valve and XD-074 strainer. The larger size will mate with Type AA thermostatic expansion valve and 8006 strainer. The mating flanges, gaskets, and bolts should be ordered separately. The bolt length varies according to the assembly being made.

During installation of the sight glass, tighten the bolts carefully and uniformly to avoid putting an undue strain on the glass. The plating gives these products initial corrosion resistance. However, for long term use in an ammonia plant, they should be painted to obtain further corrosion protection.

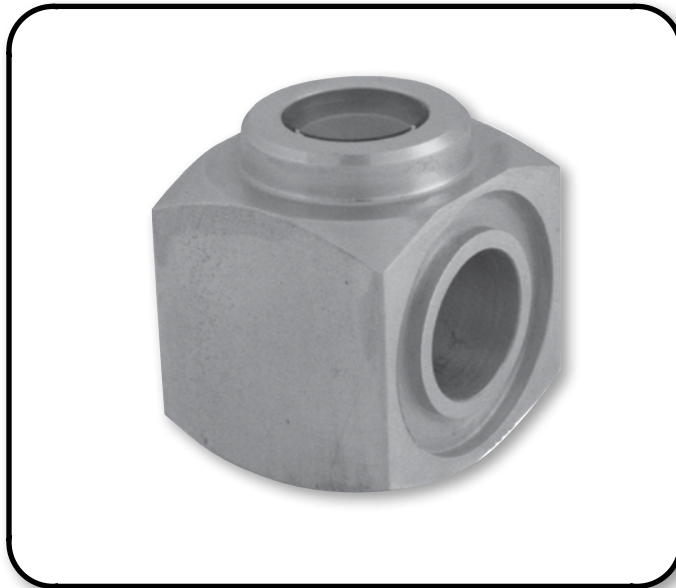

Specifications

Maximum Rated Pressure (MRP) 34.5 barg (500 psig)

General Information

Sight Glass	Flange Groove OD x ID	Used With R/S Part Number		Bolt Length (inches)	Bolt Diameter (inches)	Dimensions (Inches)		Net Weight (lbs)
		TXV	Flange (inches)			Height	Length	
SA K87	1 1/8 x 3/4	DA	1/4, 3/8, or 1/2 FPT	3	7/16	1.87	1.36	0.75
SA K90	1 3/4 x 1 1/4	AA	1/2, 3/4, or 1 FPT	5	1/2	2.25	1.88	1.50

1 Flanges are supplied with TXV. Flanges can be ordered as part kits.

2 One gasket is supplied with sight glass. Gaskets can be ordered separately.

Constant Pressure Expansion Valve (PDA)

The PDA-1-0/80 constant pressure or automatic expansion valve is a downstream pressure regulating device that is applicable on ammonia (R-717) systems. The valve regulates the mass flow rate of refrigerant to maintain downstream pressure at a constant value. The normal application of this valve is to feed liquid refrigerant to an evaporator with a relatively constant heat load. However, the PDA-1-0/80 can be used to maintain a constant downstream pressure on other applications as well.

Specifications

The PDA-1-0/80 embodies the same design and construction details as the type D thermostatic expansion valve. However, the valve utilizes an element with an adjustable spring assembly in place of the thermostatic element. Also, a non-adjustable bottom cap replaces the external superheat adjustment. The adjustment range is 0 to 80 psig with a standard setting of 60 psig.



PDA

General Information

Valve Type	Nominal Capacity		Port Size (inches)	Discharge Tube Size (Tons)	Adjustment Range (psig)	Dimensions (Inches)		Flange Ring Size (Approx.) OD x ID (inches)	Net Weight	
	kW	tons				Inlet	Outlet		kg	lbs
PDA-1-0/80	3.52	1	1/16	1/32	0/80	1/4, 3/8, or 1/2 FPT		1.12 x 0.75	3.6	8.0

PDA Capacities - R717 (kW)

Valve Type	Nominal Capacity (kW)	Port Size (inches)	Discharge Tube Size (inches)	Evaporator Temperature (°C)											
				4°				-7°				-15°			
				Pressure Drop Across Valve (bar)											
				5.5	6.9	8.3	9.7	6.9	8.3	9.7	11	6.9	8.3	9.7	11
PDA	3.52	1/16	1/32	6.72	7.88	8.90	9.81	6.22	7.17	7.98	8.72	4.89	5.70	6.40	7.03

Valve Type	Nominal Capacity (kW)	Port Size (inches)	Discharge Tube Size (inches)	Evaporator Temperature (°C)											
				-23°				-29°				-34°			
				Pressure Drop Across Valve (bar)											
				5.5	6.9	8.3	9.7	6.9	8.3	9.7	11	6.9	8.3	9.7	11
PDA	3.52	1/16	1/32	3.13	3.52	3.90	4.25	2.57	2.95	3.27	3.55	2.22	2.57	2.85	3.09

The rating are based on 30°C liquid entering the expansion valve, a maximum superheat change of -14°F, and standard factory settings.

PDA Capacities - R717 (TONS)

Valve Type	Nominal Capacity (tons)	Port Size (inches)	Discharge Tube Size (inches)	Evaporator Temperature (°F)											
				40 °				20 °				5 °			
				Pressure Drop Across Valve (psi)											
				80	100	120	140	100	120	140	160	100	120	140	160
PDA	1	1/16	1/32	1.91	2.24	2.53	2.79	1.77	2.04	2.27	2.48	1.39	1.62	1.82	2.00

Valve Type	Nominal Capacity (tons)	Port Size (inches)	Discharge Tube Size (inches)	Evaporator Temperature (°F)											
				-10 °				-20 °				-30 °			
				Pressure Drop Across Valve (psi)											
				80	100	120	140	100	120	140	160	100	120	140	160
PDA	1	1/16	1/32	0.89	1.00	1.11	1.21	0.73	0.84	0.93	1.01	0.63	0.73	0.81	0.88

The rating are based on 86°F liquid entering the expansion valve, a maximum superheat change of 7 °F, and standard factory settings.

A P P E N D I X

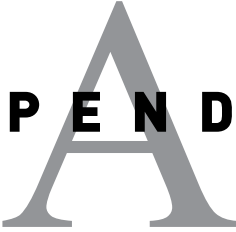

Schematic Flow Diagrams

A4 Schematic Flow Diagrams	<u>161</u>
Dual Position Valves Schematic Flow Diagrams	<u>165</u>

A4 Adaptomode® Schematic Flow Diagrams

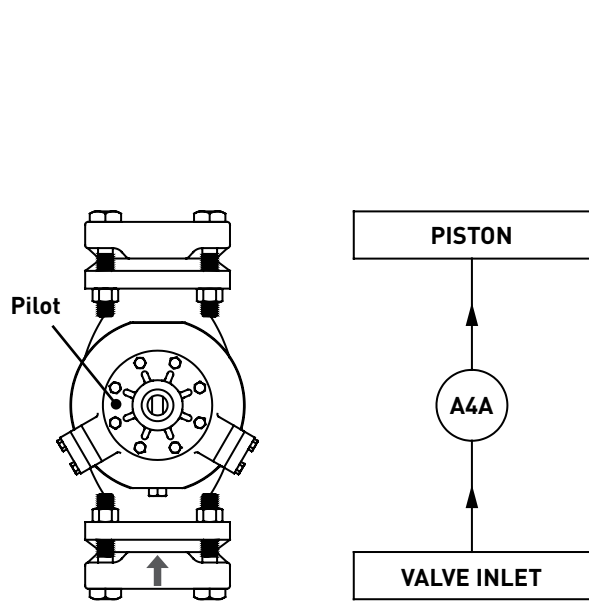

Flow Diagram: A4_Z Inlet Pressure Regulator

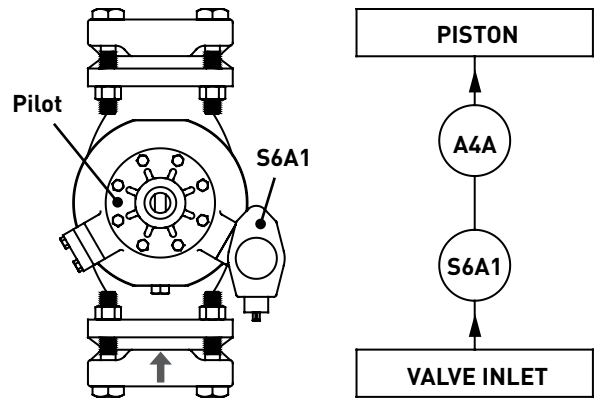

A4_S Inlet Pressure Regulator	
Control Function	Operation
	S6A1
Pressure Pilot	Energized
Shut-Off	De-Energized

Flow Diagram: A4_S Inlet Pressure Regulator with Electric Shut-Off

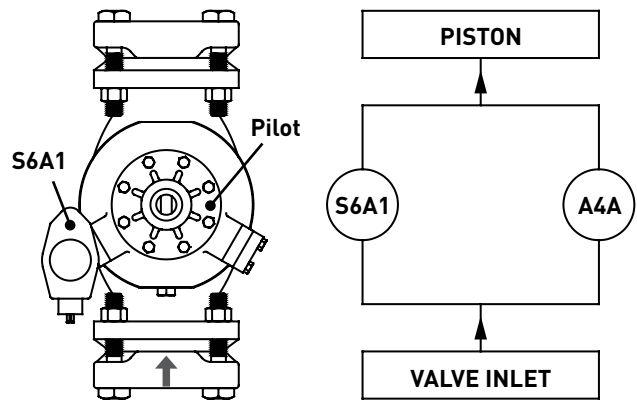

A4_B Inlet Pressure Regulator	
Control Function	Operation
	S6A1
Pressure Pilot	De-Energized
Wide Open	Energized

Flow Diagram: A4_B Inlet Pressure Regulator with Electric Bypass

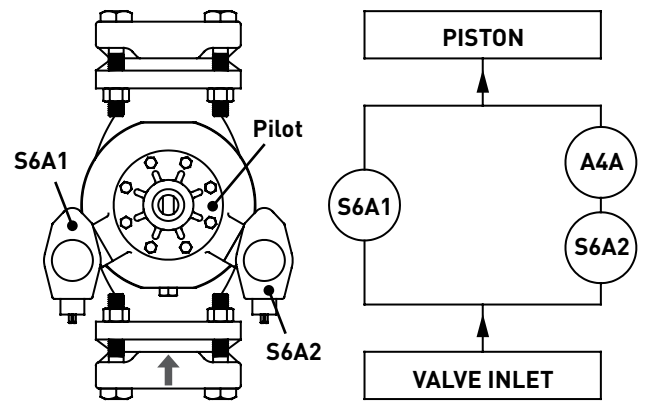

A4_BS Inlet Pressure Regulator		
Control Function	Operation	
	S6A1	S6A2
Low Pressure Pilot	De-Energized	Energized
Shut-Off	De-Energized	De-Energized
Wide Open	Energized	Energized or De-Energized

Flow Diagram: A4_BS Inlet Pressure Regulator with Electric Bypass and Shut-Off

Appendix A

A4 Adaptomode® Schematic Flow Diagrams

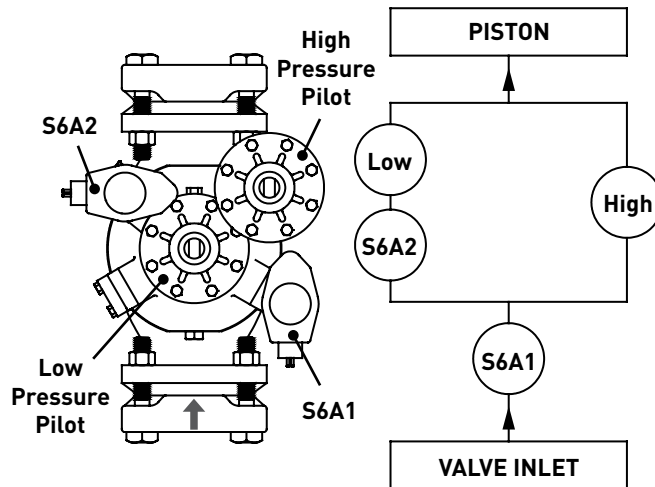
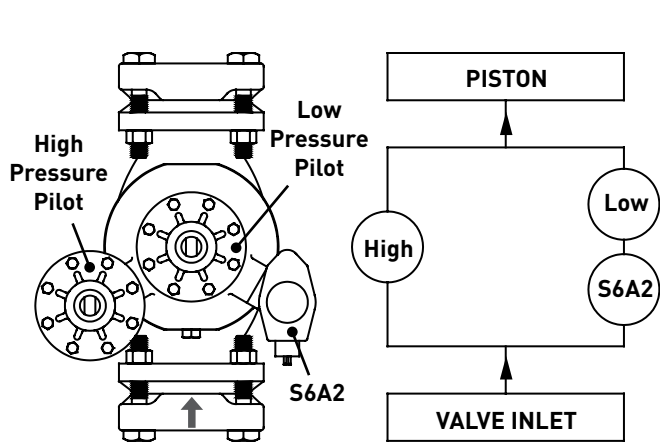

A4_D Dual Inlet Pressure Regulator	
Control Function	Operation
	S6A2
Low Pressure Pilot	Energized
High Pressure Pilot	De-Energized

A4_DS Dual Inlet Pressure Regulator		
Control Function	Operation	
	S6A1	S6A2
Low Pressure Pilot	Energized	Energized
High Pressure Pilot	Energized	De-Energized
Shut-Off	De-Energized	Energized or De-Energized

Flow Diagram: A4_D Dual Inlet Pressure Regulator

Flow Diagram: A4_DS Dual Inlet Pressure Regulator with Electric Shut-Off

Appendix A

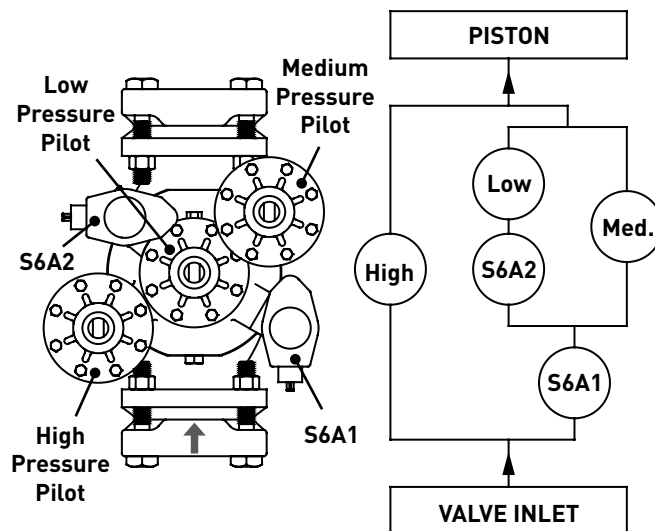
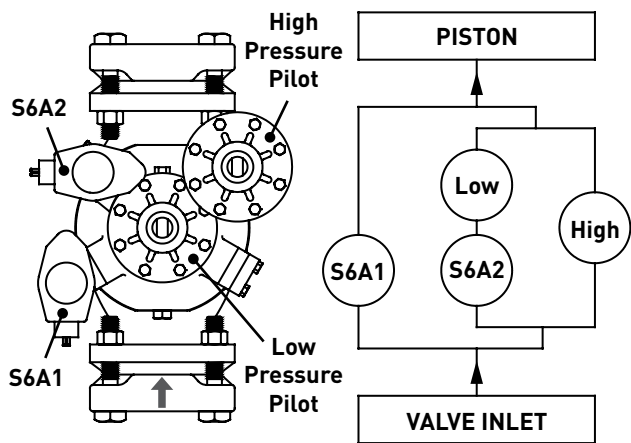

A4_DB Dual Inlet Pressure Regulator		
Control Function	Operation	
	S6A1	S6A2
Low Pressure Pilot	De-Energized	Energized
High Pressure Pilot	De-Energized	De-Energized
Wide Open	Energized	Energized or De-Energized

A4_DD Tri Inlet Pressure Regulator		
Control Function	Operation	
	S6A1	S6A2
Low Pressure Pilot	Energized	Energized
Medium Pressure Pilot	Energized	De-Energized
High Pressure Pilot	De-Energized	Energized or De-Energized

Flow Diagram: A4_DB Dual Inlet Pressure Regulator with Electric Bypass

Flow Diagram: A4_DD Tri Inlet Pressure Regulator

A4 Adaptomode® Schematic Flow Diagrams

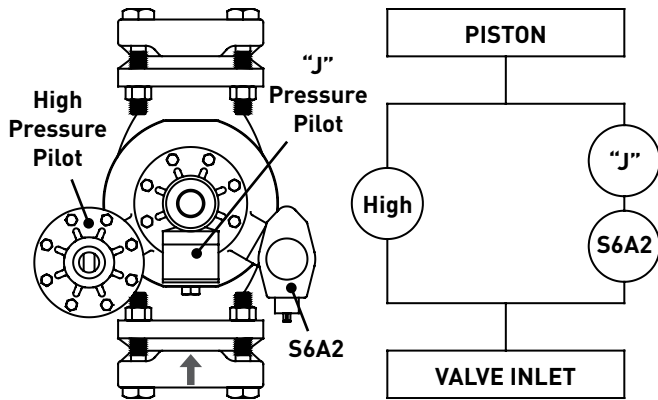

A4_DJ Dual Inlet Pressure Regulator	
Control Function	Operation
	S6A2
"J" Pressure Pilot	Energized
High Pressure Pilot	De-Energized

Flow Diagram: A4_DJ Inlet Dual Pressure Regulator

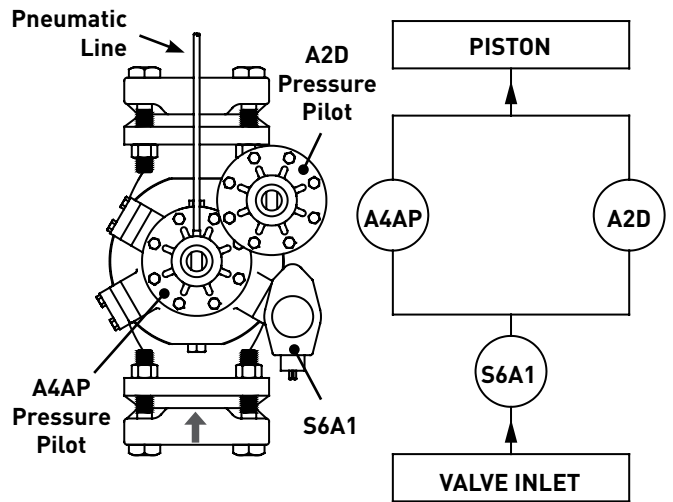

A4_DPS Pneumatically Compensated Inlet Pressure Regulator		
Control Function	Operation	
	S6A1	Note
A4AP Pressure Pilot	Energized	When S6A1 is energized either the A4AP or the A2D (high pressure pilot) will control, whichever ever has the lower set point.
A2D Pressure Pilot	Energized	
Shut-Off	De-Energized	

Flow Diagram: A4_DPS Pneumatically Compensated Inlet Pressure Regulator with Electric Shut-Off

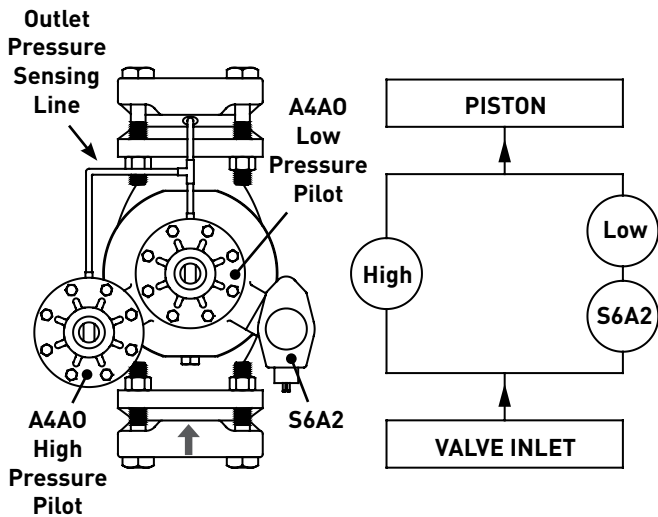

A4_DO Dual Outlet Pressure Regulator	
Control Function	Operation
	S6A2
Low Pressure Pilot	Energized
High Pressure Pilot	De-Energized

Flow Diagram: A4_DO Dual Outlet Pressure Regulator

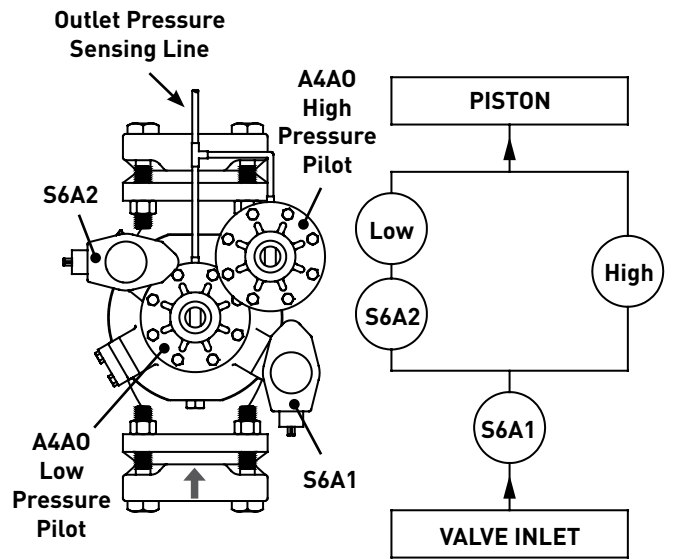

A4_DOES Dual Outlet Pressure Regulator		
Control Function	Operation	
	S6A1	S6A2
Low Pressure Pilot	Energized	Energized
High Pressure Pilot	Energized	De-Energized
Shut-Off	De-Energized	Energized or De-Energized

Flow Diagram: A4_DOES Dual Outlet Pressure Regulator with Electric Shut-Off

Appendix A

A4 Adaptomode® Schematic Flow Diagrams

Low Pressure Drop Option (LPD)

With the conventional evaporator regulator, a minimum of 0.14 bar (2 psi) pressure across the main valve is required for the valve to be fully open. The Low Pressure Drop feature added to a Type A4 inlet or outlet pressure regulator permits full flow modulation with pressure drops down to 0.04 bar (½ psi).

The principle of operation for the LPD is to provide high pressure refrigerant to the A2BOP pilot inlet line. Reduce this high pressure to a lower pressure and control it to follow the main regulator upstream pressure always at a fixed differential, approximately 0.35 bar (5 psi). Use this controlled following pressure through the pilot

circuit and to the top of the piston, where it will operate the main valve independently of the main line pressure drop. The controlled following pressure from the A2BOP must be enough higher than the upstream pressure to provide reliable operation at all times, but not so high at any time as to cause excessive leakage, which would reduce evaporator capacity.

All Type A4 Regulating Valves arranged for LPD operation must also be sized for LPD operation. The capacity of a regulator at 0.04 bar (½ psi) pressure drop will be 50% of the capacity at 0.14 bar (2 psi) pressure drop for the same inlet conditions.

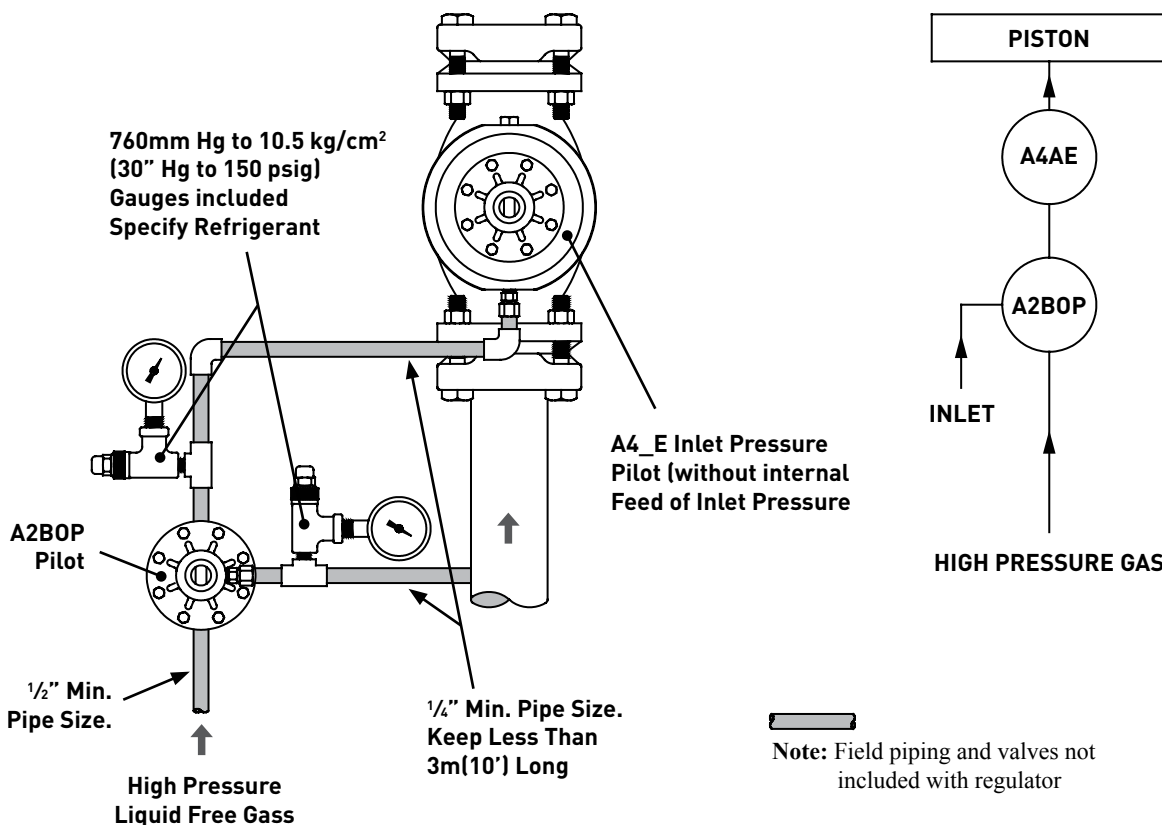

Flow Diagram: A4_ Low Pressure Drop (LPD) Inlet Dual Pressure Regulator

The basic LPD assembly includes:

- Compensated pressure regulator (A2BOP)
- Gauge valves: 2 with inlet regulator, 3 with outlet regulator
- 760mm Hg to 10.5 bar (30" Hg to 150 lb.) gauges: 2 with inlet regulator, 3 with outlet regulator

Note: Not available with Variations E, L, K or R.

Dual Position Valves Schematic Flow Diagrams

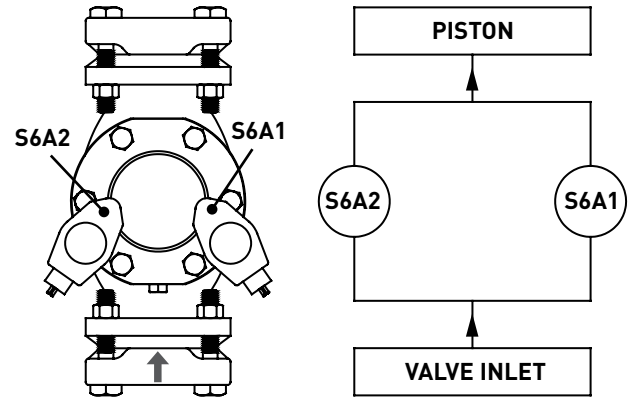
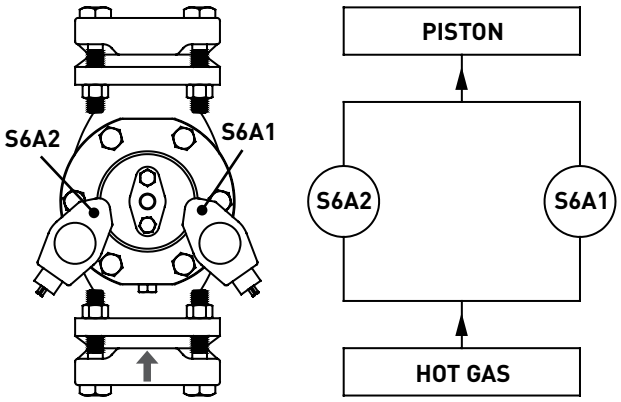

CK-2D Dual Position Gas Powered Suction Stop Valve		
Control Function	Operation	
	S6A1	S6A2
Full Open	De-Energized	De-Energized
Full Closed	Energized	Energized
Equalize	De-Energized	Energized

S4AD Dual Position Solenoid Valve		
Control Function	Operation	
	S6A1	S6A2
Full Open	Energized	Energized
Full Closed	De-Energized	De-Energized
Equalize	De-Energized	Energized

Flow Diagram: CK-2D Dual Position Gas Powered Suction Stop Valve

Flow Diagram: S4AD Dual Position Solenoid Valve

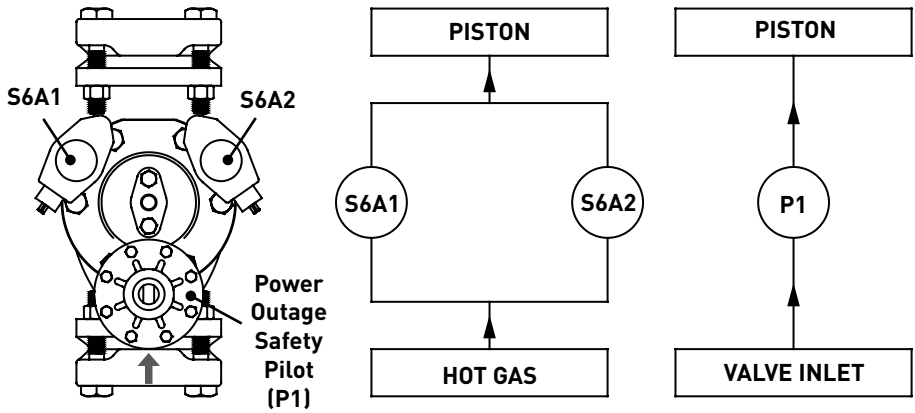

CK-6D Dual Position Gas Powered Suction Stop Valve		
Control Function	Operation	
	S6A1	S6A2
Full Open	De-Energized	De-Energized
Full Closed	Energized	Energized
Equalize	De-Energized	Energized

Flow Diagram: CK-6D Dual Position Gas Powered Suction Stop Valve

Appendix A

A P P E N D I X

Dimensional Diagrams

A4 Adaptomode ® Series Pressure Regulators	<u>167</u>	Modulating Refrigerant Valve (MVS)	<u>209</u>
Check Valves	<u>187</u>	Rapid Purger (V200)	<u>208</u>
Compact Pressure Regulators	<u>177</u>	Refrigerant Distributors	<u>211</u>
Constant Pressure Expansion Valve (PDA)	<u>215</u>	Replaceable Core Filter Dryer	<u>213</u>
Dual Position Gas Powered Suction Stop Valves	<u>186</u>	Safety Relief Vavles	<u>198</u>
Dual Position Solenoid Valves	<u>181</u>	SA K87 and SA K90 Sight Glass	<u>215</u>
Flanges	<u>192</u>	Solenoid Valves	<u>178</u>
Gas Powered Suction Stop Valves	<u>182</u>	Strainers	<u>190</u>
Hand Shut-Off and Hand Expansion Vavles	<u>201</u>	Thermostatic Expansion Valves (TXV)	<u>210</u>
Level Master Control (LMC)	<u>210</u>	XD and Y Type Strianers	<u>214</u>
Liquid Level Controls	<u>206</u>	XJH and XOP Solenoid Valves	<u>213</u>

A4 Adaptomode® Series Pressure Regulators

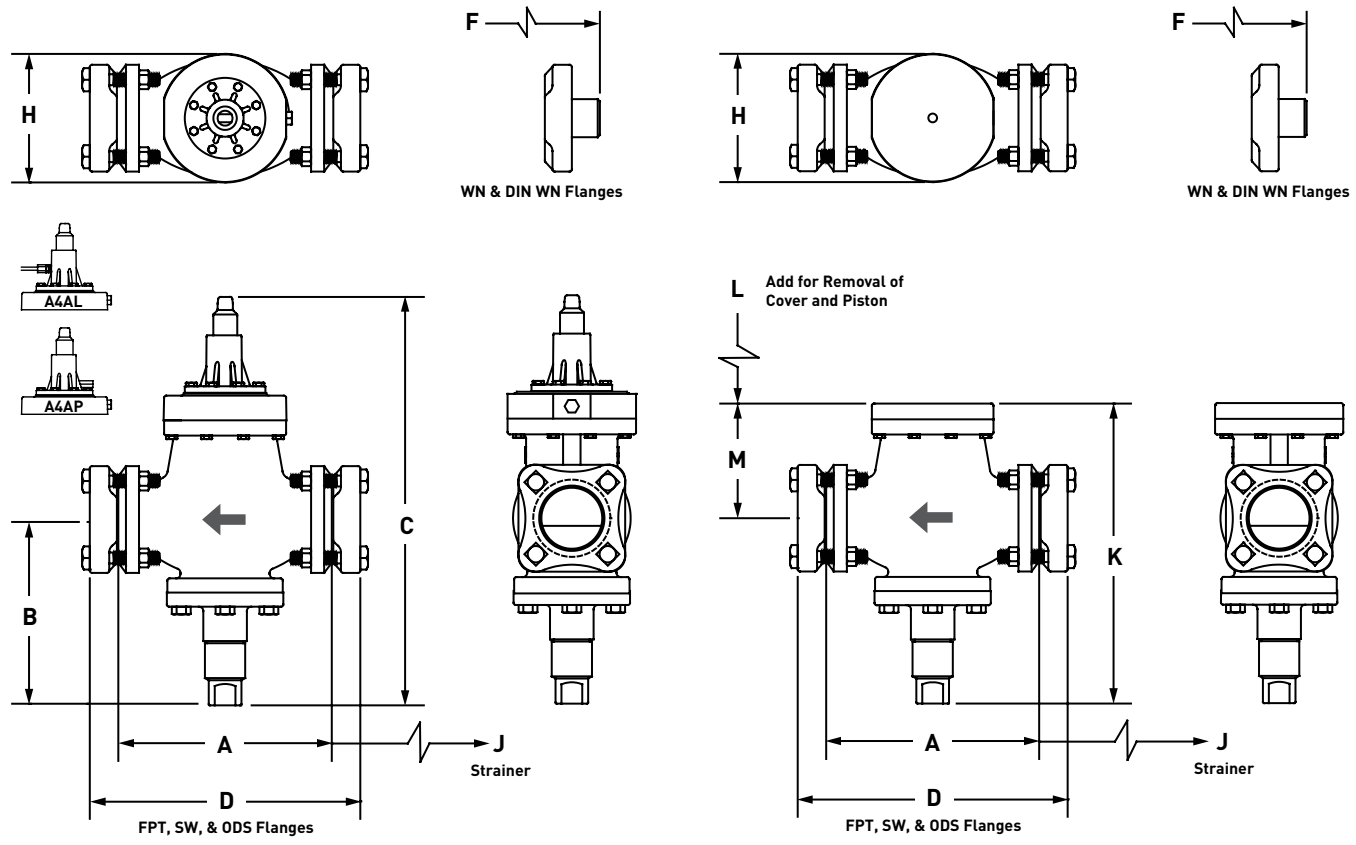

Dimensional Diagram: A4A,E,K,L & P Inlet Pressure Regulator

Dimensional Diagram: A4AR Inlet Pressure Regulator

Port Size		A		B*		C		H		J		K		L		M	
mm	inch	mm	inch	mm	inch	mm	inch	mm	inch	mm	inch	mm	inch	mm	inch	mm	inch
20 -25	¾ - 1	164	6.2	147	5.8	392	15.4	117	4.6	150	5.9	241	9.5	71	2.8	97	3.8
32	1¼	203	8.0	160	6.3	410	16.1	117	4.6	178	7.0	254	10.0	76	3.0	102	4.0
40 - 50	1½ - 2	251	9.9	175	6.9	464	18.2	140	5.5	251	9.9	307	12.1	114	4.5	140	5.5
65	2½	252	9.9	180	7.1	483	19.0	159	6.2	315	12.4	325	12.8	130	5.1	155	6.1
75	3	311	12.2	272	10.7	597	23.5	176	7.0	315	12.4	432	17.0	152	6.0	178	7.0
100	4	359	14.1	292	11.5	653	25.7	222	8.9	363	14.3	478	18.8	157	6.2	183	7.2

* Allow 25mm (1") below valve to operate manual opening stem

Port Size		D						F					
		FPT*, SW			ODS			WN			DIN WN		
mm	inch	Connection	mm	inch	Connection	mm	inch	Connection	mm	inch	Connection	mm	inch
20 - 25	¾ - 1	¾"	211	8.3	7/8"	211	8.3	¾"	246	9.7	20mm	248	9.8
		1"			1"			254	10.0	25mm	255	10.0	
		1¼"			1¼"			325	12.8	32mm	304	12.0	
32	1¼	1½"	254	10.0	1½"	254	10.0	1½"	312	12.3	38mm	313	12.3
		1½"			1½"			366	14.4	38mm	364	14.4	
40 - 50	1½ - 2	2"	307	12.1	2 1/8"	307	12.1	1½"	378	14.9	50mm	371	14.6
		2"			2"			378	14.9	50mm	371	14.6	
65	2½	2½"	318	12.5	2 5/8"	318	12.5	2½"	389	15.3	65mm	388	15.3
		3"			3"			406	16.0				
75	3	3"	376	14.8	3 1/8"	376	14.8	3"	465	18.3	75mm	465	18.3
					3 5/8"								
100	4	4"	432	17.0	4 1/8"	432	17.0	4"	551	21.7	100mm	552	21.7

* FPT flanges are only available in 20 - 50mm (¾" - 2")

Appendix B

A4 Adaptomode® Series Pressure Regulators

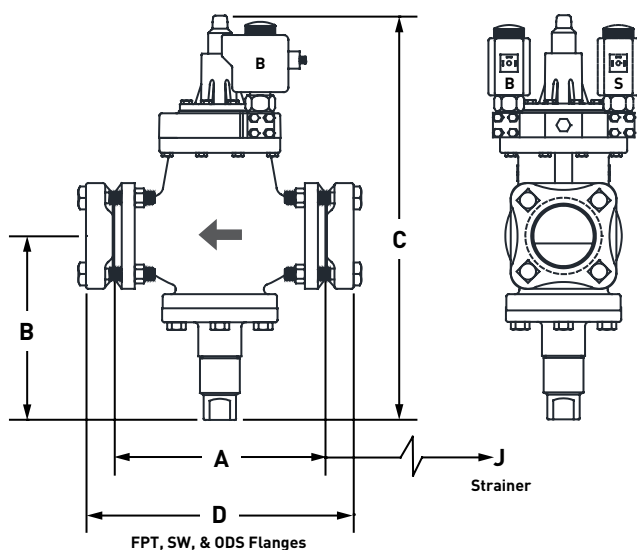
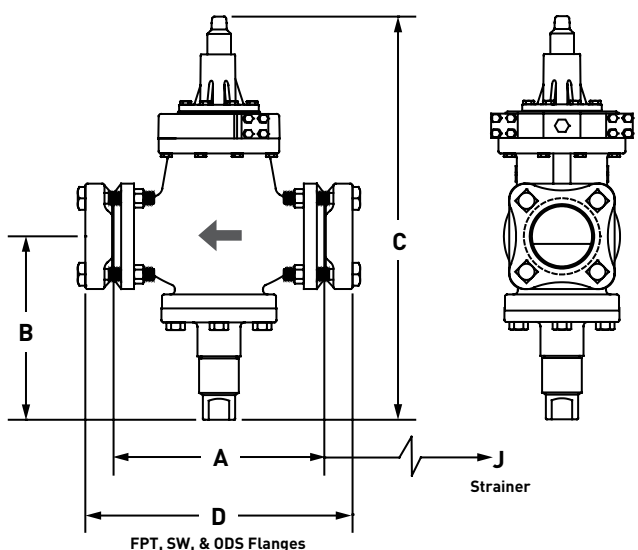
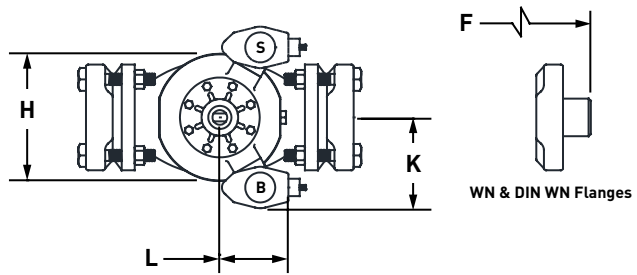
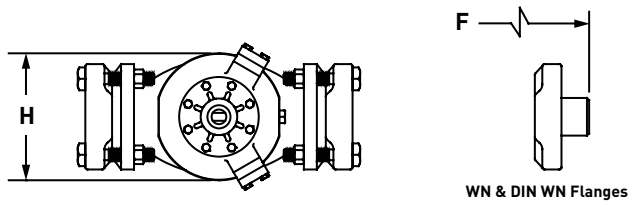

Dimensional Diagram: A4AZ Inlet Pressure Regulator

Dimensional Diagram 4: A4AB,S, & BS Inlet Pressure Regulator

Port Size		A		B*		C		H		J		K		L	
mm	inch	mm	inch	mm	inch	mm	inch	mm	inch	mm	inch	mm	inch	mm	inch
20 -25	¾ - 1	164	6.2	147	5.8	392	15.4	117	4.6	150	5.9	112	4.4	122	4.8
32	1¼	203	8.0	160	6.3	410	16.1	117	4.6	178	7.0	112	4.4	122	4.8
40 - 50	1½ - 2	251	9.9	175	6.9	464	18.2	140	5.5	251	9.9	117	4.6	135	5.3
65	2½	252	9.9	180	7.1	483	19.0	159	6.2	315	12.4	124	4.9	133	5.2
75	3	311	12.2	272	10.7	597	23.5	176	7.0	315	12.4	142	5.6	122	4.8
100	4	359	14.1	292	11.5	653	25.7	222	8.9	363	14.3	157	6.2	152	6.0

* Allow 25mm (1") below valve to operate manual opening stem

Port Size		D						F					
		FPT*, SW			ODS			WN			DIN WN		
mm	inch	Connection	mm	inch	Connection	mm	inch	Connection	mm	inch	Connection	mm	inch
20 - 25	¾ - 1	¾"	211	8.3	7/8"	211	8.3	¾"	246	9.7	20mm	248	9.8
		1"			1"			254	10.0	25mm	255	10.0	
		1¼"			1¼"			325	12.8	32mm	304	12.0	
32	1¼	1"	254	10.0	1½"	254	10.0	1½"	312	12.3	38mm	313	12.3
		1½"			1½"			366	14.4	38mm	364	14.4	
40 - 50	1½ - 2	2"	307	12.1	2½"	307	12.1	2"	378	14.9	50mm	371	14.6
		2½"			2½"			389	15.3	65mm	388	15.3	
65	2½	3"	318	12.5	3½"	318	12.5	3"	406	16.0	75mm	465	18.3
		3"			3"			465	18.3	75mm	465	18.3	
75	3	3"	376	14.8	3"	376	14.8	3"	465	18.3	75mm	465	18.3
100	4	4"	432	17.0	4½"	432	17.0	4"	551	21.7	100mm	552	21.7

* FPT flanges are only available in 20 - 50mm (¾" - 2")

Appendix B

A4 Adaptomode® Series Pressure Regulators

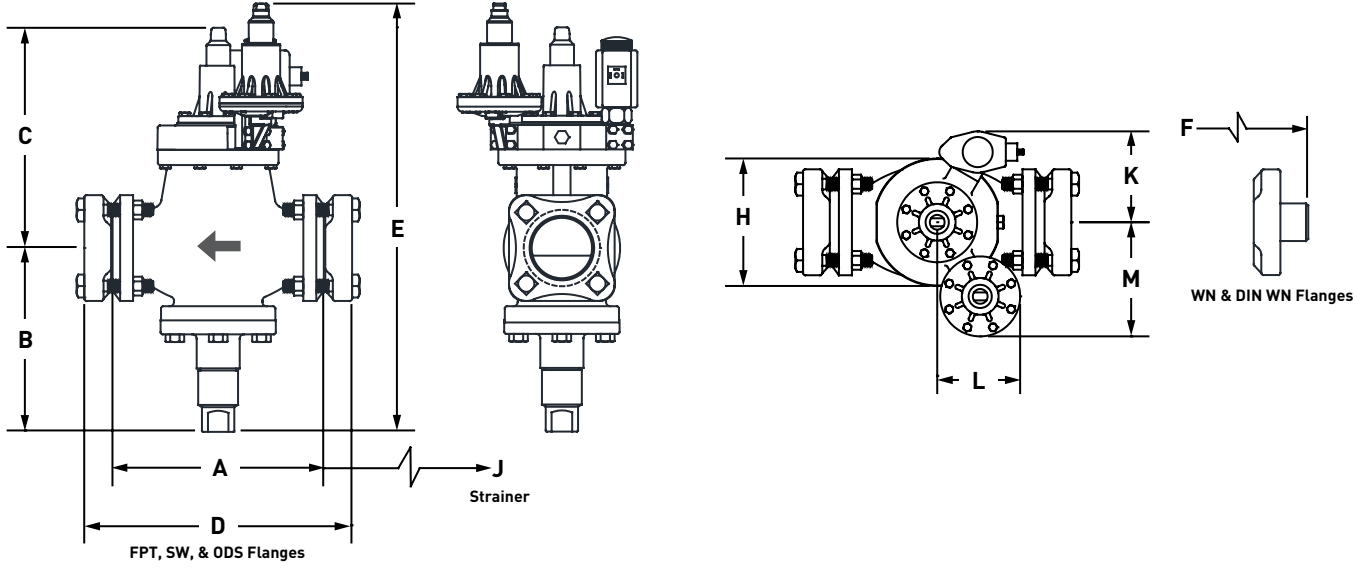

Dimensional Diagram: A4AD Dual Inlet Pressure Regulator

Port Size		A		B*		C		E		H		J		K		L		M	
mm	inch	mm	inch	mm	inch	mm	inch	mm	inch	mm	inch	mm	inch	mm	inch	mm	inch	mm	inch
20 -25	¾ - 1	164	6.2	147	5.8	244	9.6	427	16.8	117	4.6	150	5.9	112	4.4	122	4.8	138	5.4
32	1¼	203	8.0	160	6.3	249	9.8	442	17.4	117	4.6	178	7.0	112	4.4	122	4.8	138	5.4
40 - 50	1½ - 2	251	9.9	175	6.9	287	11.3	493	19.4	140	5.5	251	9.9	117	4.6	135	5.3	140	5.5
65	2½	252	9.9	180	7.1	302	11.9	513	20.2	159	6.2	315	12.4	124	4.9	133	5.2	150	5.9
75	3	311	12.2	272	10.7	325	12.8	615	24.2	176	7.0	315	12.4	142	5.6	122	4.8	170	6.6
100	4	359	14.1	292	11.5	361	14.2	671	26.4	222	8.9	363	14.3	157	6.2	152	6.0	190	7.7

* Allow 25mm (1") below valve to operate manual opening stem

Port Size		D						F					
		FPT*, SW			ODS			WN			DIN WN		
mm	inch	Connection	mm	inch	Connection	mm	inch	Connection	mm	inch	Connection	mm	inch
20 - 25	¾ - 1	¾"	211	8.3	7/8"	211	8.3	¾"	246	9.7	20mm	248	9.8
		1"			1"			254	10.0	25mm	255	10.0	
		1¼"			1¼"			325	12.8	32mm	304	12.0	
32	1¼	1"	254	10.0	1½"	254	10.0	1½"	312	12.3	38mm	313	12.3
		1½"			1½"			366	14.4	38mm	364	14.4	
40 - 50	1½ - 2	2"	307	12.1	2½"	307	12.1	2"	378	14.9	50mm	371	14.6
		2½"			2½"			389	15.3	65mm	388	15.3	
65	2½	3"	318	12.5	3½"	318	12.5	3"	406	16.0			
		3"			3"			465	18.3	75mm	465	18.3	
75	3	3"	376	14.8	3½"	376	14.8	3"	465	18.3	75mm	465	18.3
100	4	4"	432	17.0	4½"	432	17.0	4"	551	21.7	100mm	552	21.7

* FPT flanges are only available in 20 - 50mm (¾" - 2")

Appendix B

A4 Adaptomode® Series Pressure Regulators

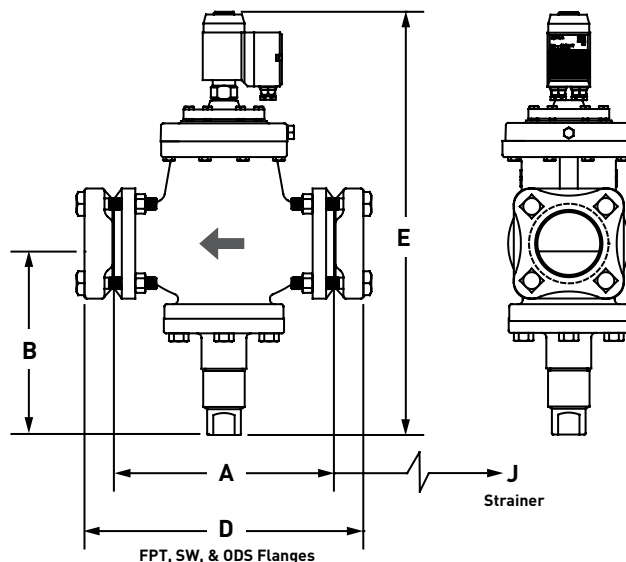
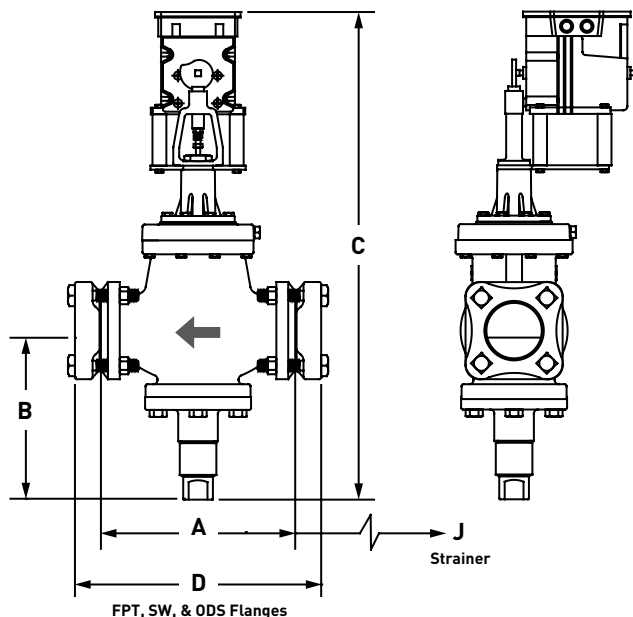
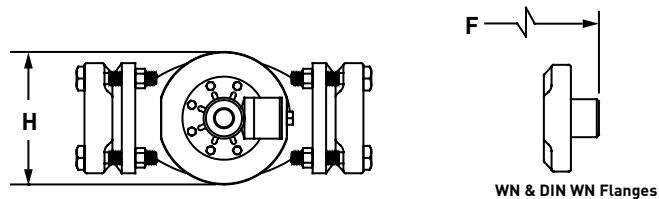
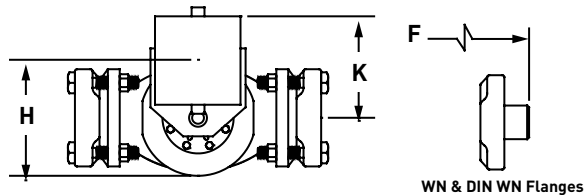

Dimensional Diagram: A4AM, OM Electrically Compensated Pressure Regulator

Dimensional Diagram: A4AJ Electric Pilot Pressure Regulator

Port Size		A		B*		C (A4AM)		C (A4AOM)		E		H		J		K	
mm	inch	mm	inch	mm	inch	mm	inch	mm	inch	mm	inch	mm	inch	mm	inch	mm	inch
20 -25	¾ - 1	164	6.2	147	5.8	597	23.5	620	24.4	432	17.0	117	4.6	150	5.9	191	7.5
32	1¼	203	8.0	160	6.3	615	24.2	638	25.1	450	17.7	117	4.6	178	7.0	191	7.5
40 - 50	1½ - 2	251	9.9	175	6.9	668	26.3	691	27.2	503	19.8	140	5.5	251	9.9	191	7.5
65	2½	252	9.9	180	7.1	688	27.1	711	30.4	523	20.6	159	6.2	315	12.4	191	7.5
75	3	311	12.2	272	10.7	803	31.6	826	32.5	635	25.0	176	7.0	315	12.4	191	7.5
100	4	359	14.1	292	11.5	859	33.8	882	34.7	693	27.3	222	8.9	363	14.3	191	7.5

* Allow 25mm (1") below valve to operate manual opening stem

Port Size		D						F					
		FPT*, SW			ODS			WN			DIN WN		
mm	inch	Connection	mm	inch	Connection	mm	inch	Connection	mm	inch	Connection	mm	inch
20 - 25	¾ - 1	¾"	211	8.3	7/8"	211	8.3	¾"	246	9.7	20mm	248	9.8
		1"			1"			254	10.0	25mm	255	10.0	
		1¼"			1¼"			325	12.8	32mm	304	12.0	
32	1¼	1½"	254	10.0	1½"	254	10.0	1½"	312	12.3	38mm	313	12.3
		1½"			1½"			366	14.4	38mm	364	14.4	
40 - 50	1½ - 2	2"	307	12.1	2½"	307	12.1	2"	378	14.9	50mm	371	14.6
		2"			2"			389	15.3	65mm	388	15.3	
65	2½	3"	318	12.5	3"	318	12.5	3"	406	16.0	75mm	465	18.3
		3"			3"			465	18.3	75mm	465	18.3	
75	3	3"	376	14.8	3"	376	14.8	3"	465	18.3	75mm	465	18.3
100	4	4"	432	17.0	4"	432	17.0	4"	551	21.7	100mm	552	21.7

* FPT flanges are only available in 20 - 50mm (¾" - 2")

A4 Adaptomode® Series Pressure Regulators

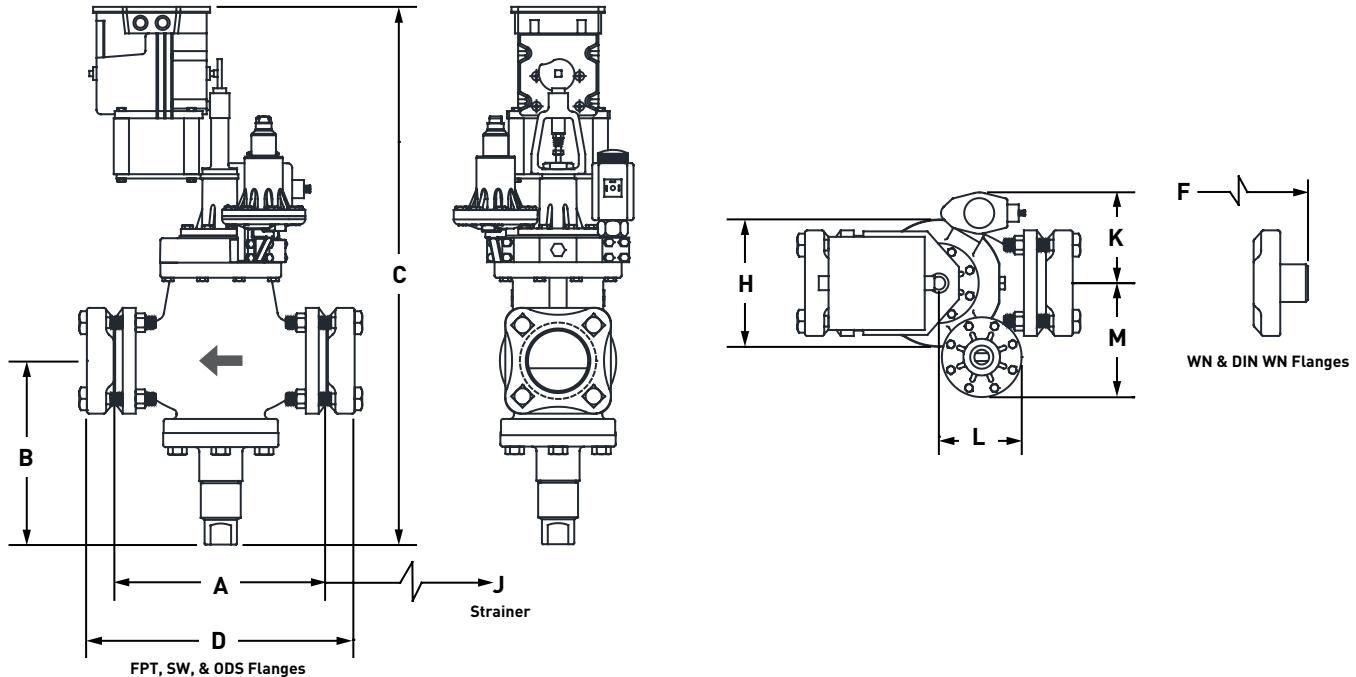

Dimensional Diagram: A4ADM Electrically Compensated Dual Inlet Pressure Regulator

Port Size		A		B*		C		H		J		K		L		M	
mm	inch	mm	inch	mm	inch	mm	inch	mm	inch	mm	inch	mm	inch	mm	inch	mm	inch
20 -25	¾ - 1	164	6.2	147	5.8	734	28.9	117	4.6	150	5.9	112	4.4	122	4.8	138	5.4
32	1¼	203	8.0	160	6.3	762	30.1	117	4.6	178	7.0	112	4.4	122	4.8	138	5.4
40 - 50	1½ - 2	251	9.9	175	6.9	833	32.8	140	5.5	251	9.9	117	4.6	135	5.3	140	5.5
65	2½	252	9.9	180	7.1	859	33.8	159	6.2	315	12.4	124	4.9	133	5.2	150	5.9
75	3	311	12.2	272	10.7	1064	41.9	176	7.0	315	12.4	142	5.6	122	4.8	170	6.6
100	4	359	14.1	292	11.5	1140	44.9	222	8.9	363	14.3	157	6.2	152	6.0	190	7.7

* Allow 25mm (1") below valve to operate manual opening stem

Port Size		D						F					
		FPT*, SW			ODS			WN			DIN WN		
mm	inch	Connection	mm	inch	Connection	mm	inch	Connection	mm	inch	Connection	mm	inch
20 - 25	¾ - 1	¾"	211	8.3	7/8"	211	8.3	¾"	246	9.7	20mm	255	10.0
		1"			1"			254	10.0				
		1¼"			1¼"			325	12.8	32mm	304		
32	1¼	1"	254	10.0	1½"	254	10.0	1½"	312	12.3	38mm	313	12.3
		1½"			1½"			366	14.4	38mm	364		
40 - 50	1½ - 2	2"	307	12.1	2½"	307	12.1	2"	378	14.9	50mm	371	14.6
		2½"			2½"			389	15.3	65mm	388		
65	2½	3"	318	12.5	3½"	318	12.5	3"	406	16.0	75mm	465	18.3
		3"			3"			465	18.3				
75	3	3"	376	14.8	3½"	376	14.8	3"	465	18.3	75mm	465	18.3
100	4	4"	432	17.0	4½"	432	17.0	4"	551	21.7	100mm	552	21.7

* FPT flanges are only available in 20 - 50mm (¾" - 2")

Appendix B

A4 Adaptomode® Series Pressure Regulators

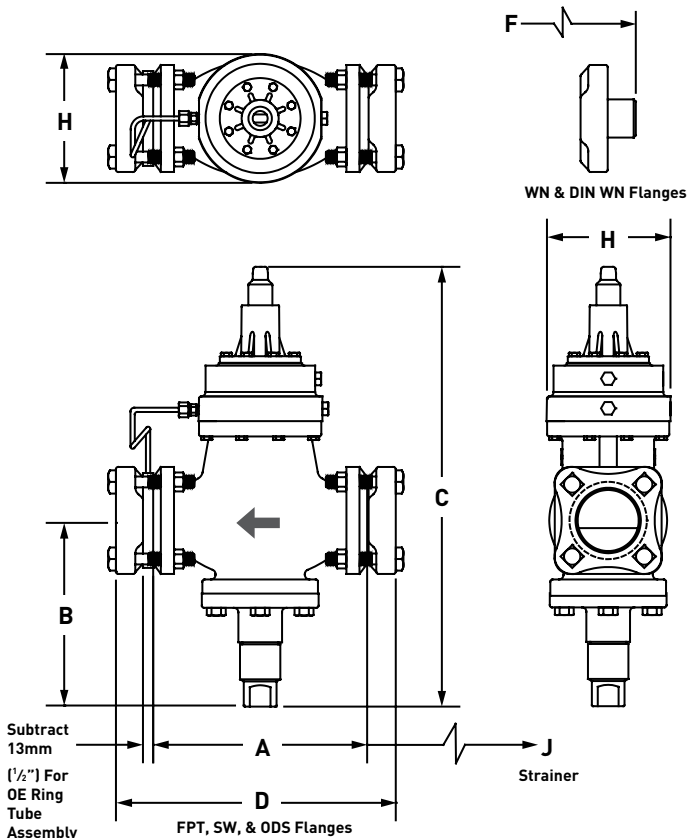

Dimensional Diagram: A4AOE Outlet Pressure Regulator

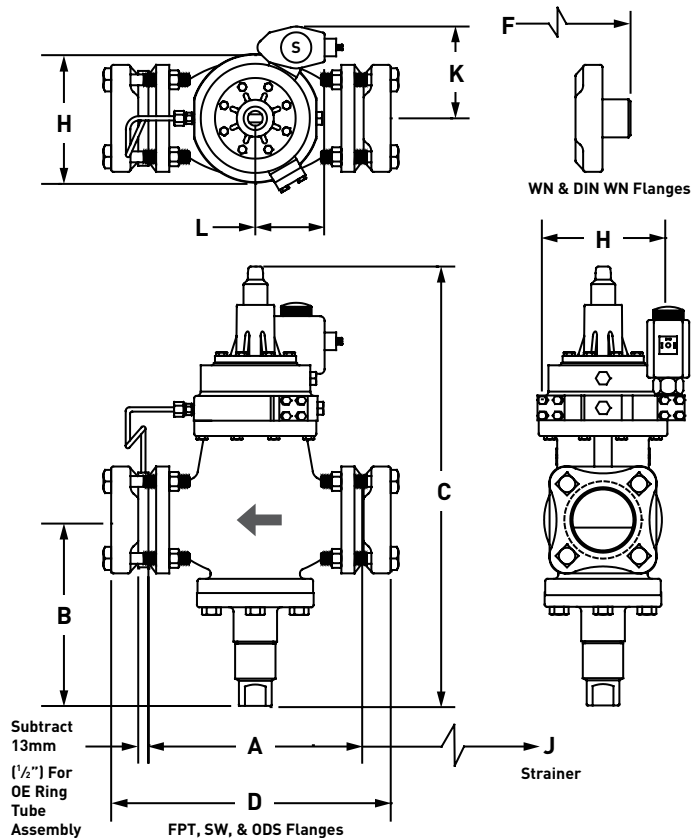

Dimensional Diagram: A4AOES Outlet Pressure Regulator

Port Size		A		B*		C		H		J		K		L	
mm	inch	mm	inch	mm	inch	mm	inch	mm	inch	mm	inch	mm	inch	mm	inch
20 -25	3/4 - 1	164	6.2	147	5.8	454	17.9	117	4.6	150	5.9	241	9.5	122	4.8
32	1 1/4	203	8.0	160	6.3	472	18.6	117	4.6	178	7.0	254	10.0	122	4.8
40 - 50	1 1/2 - 2	251	9.9	175	6.9	525	20.7	140	5.5	251	9.9	307	12.1	135	5.3
65	2 1/2	252	9.9	180	7.1	538	21.2	159	6.2	315	12.4	325	12.8	133	5.2
75	3	311	12.2	272	10.7	657	25.9	176	7.0	315	12.4	432	17.0	122	4.8
100	4	359	14.1	292	11.5	710	28.4	222	8.9	363	14.3	478	18.8	152	6.0

* Allow 25mm (1") below valve to operate manual opening stem

Port Size		D						F					
		FPT*, SW			ODS			WN			DIN WN		
mm	inch	Connection	mm	inch	Connection	mm	inch	Connection	mm	inch	Connection	mm	inch
20 - 25	3/4 - 1	3/4"	224	8.8	7/8"	224	8.8	3/4"	259	10.2	20mm	261	10.3
		1"			1 1/8"			1"	267	10.5	25mm	268	10.6
		1 1/4"			1 3/8"			1 1/4"	338	13.3	32mm	317	12.5
32	1 1/4	1 1/2"	267	10.5	1 5/8"	267	10.5	1 1/2"	325	12.8	38mm	326	12.8
		1"			1 1/2"			379	14.9	38mm	377	14.8	
40 - 50	1 1/2 - 2	2"	320	12.6	2 1/8"	320	12.6	2"	391	15.4	50mm	384	15.1
		2 5/8"			2 1/2"			402	15.8	65mm	401	15.8	
65	2 1/2	3"	331	13.0	3 1/8"	331	13.0	3"	419	16.5	75mm	479	18.8
		2 1/2"			3 5/8"			479	18.8	75mm	479	18.8	
75	3	3"	389	15.3	3 5/8"	389	15.3	3"	479	18.8	75mm	479	18.8
100	4	4"	445	17.5	4 1/8"	445	17.5	4"	564	22.2	100mm	564	22.2

* FPT flanges are only available in 20 - 50mm (3/4" - 2")

A4 Adaptomode® Series Pressure Regulators

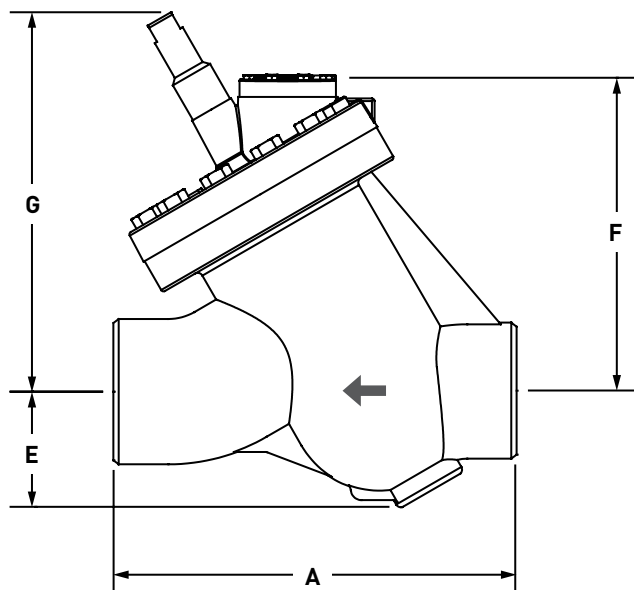
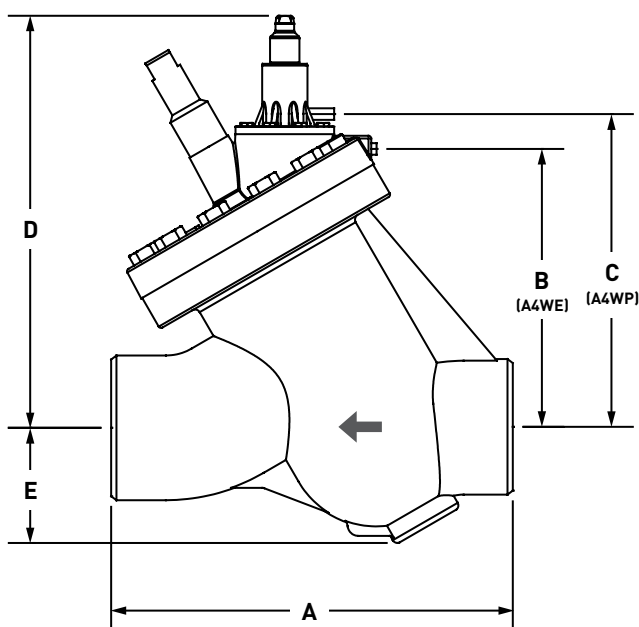
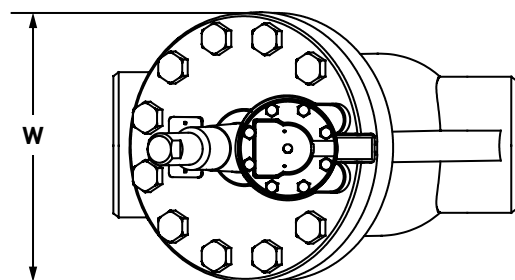
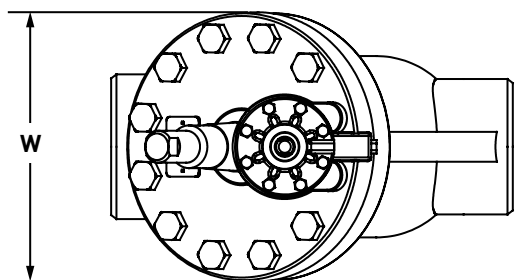

Dimensional Diagram: A4W, E, & P Inlet Pressure Regulator

Dimensional Diagram: A4WR Inlet Pressure Regulator

Port Size		A		B		C		D*		E		F		G**		W	
mm	inch	mm	inch	mm	inch	mm	inch	mm	inch	mm	inch	mm	inch	mm	inch	mm	inch
125	5	381	15.0	273	10.7	315	12.4	438	17.2	114	4.5	305	12.0	414	16.3	267	10.5
150	6	483	19.0	349	13.7	391	15.4	514	20.2	152	6.0	381	15.0	489	19.3	318	12.5
200	8	622	24.5	406	16.0	448	17.6	572	22.5	197	7.8	438	17.2	546	21.5	381	15.0

Valve body is wider than adapter for 125mm (5") A4W; Adapter wider than body for 150mm (6") & 200mm (8") A4W

* Allow 75mm (3") overhead clearance for access to adjusting stem.

** Allow 100mm (4") overhead clearance for coil or seal cap removal.

Appendix B

A4 Adaptomode® Series Pressure Regulators

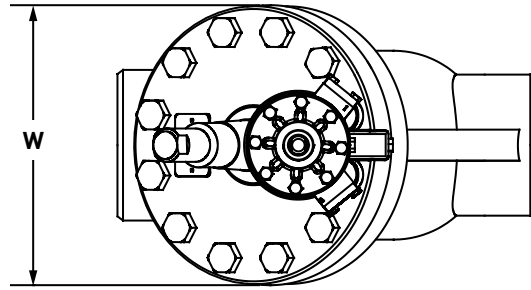
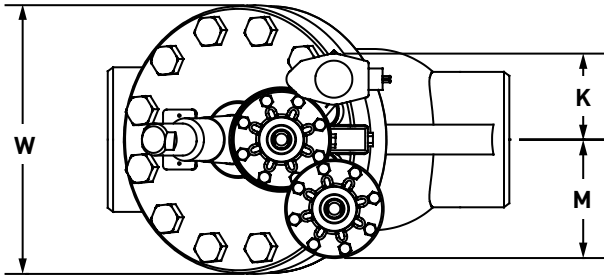

Dimensional Diagram: A4WZ Inlet Pressure Regulator

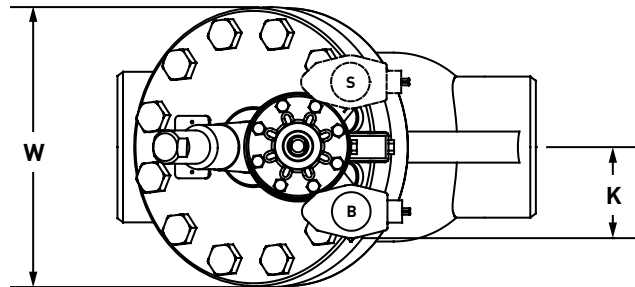
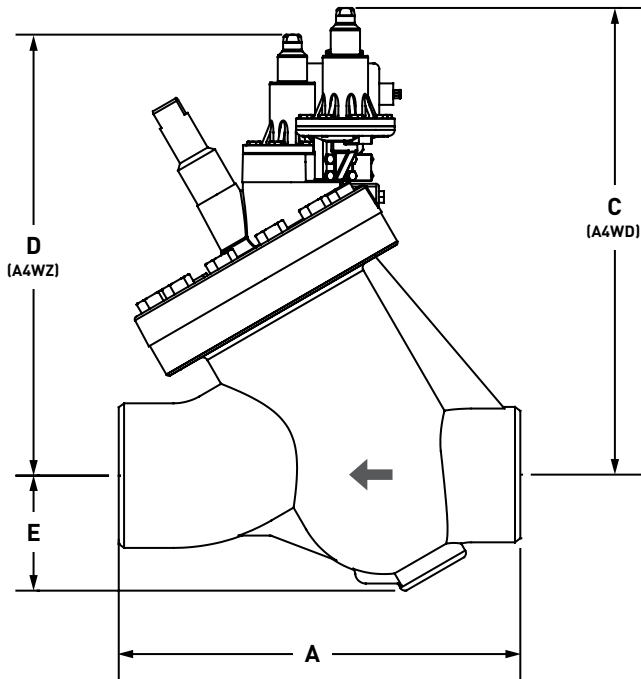

Dimensional Diagram: B, S, & BS Inlet Pressure Regulator

Dimensional Diagram: A4WD Inlet Dual Pressure Regulator

Port Size		A		C*		D*		E		K		M		W	
mm	inch	mm	inch	mm	inch	mm	inch	mm	inch	mm	inch	mm	inch	mm	inch
125	5	381	15.0	502	19.8	476	18.7	114	4.5	100	3.9	140	5.5	267	10.5
150	6	483	19.0	578	22.8	552	21.7	152	6.0	100	3.9	140	5.5	318	12.5
200	8	622	24.5	636	25.0	610	24.0	197	7.8	100	3.9	140	5.5	381	15.0

Valve body is wider than adapter for 125mm (5") A4W; Adapter wider than body for 150mm (6") & 200mm (8") A4W
 * Allow 75mm (3") overhead clearance for access to adjusting stem.

A4 Adaptomode® Series Pressure Regulators

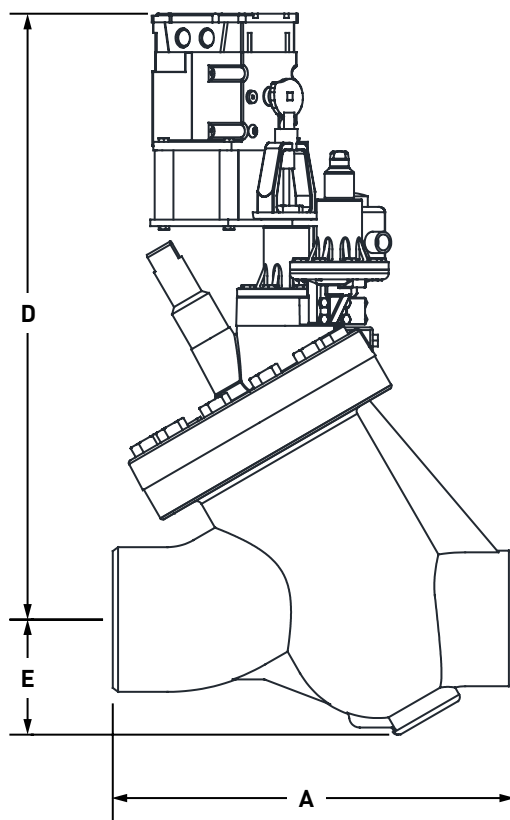
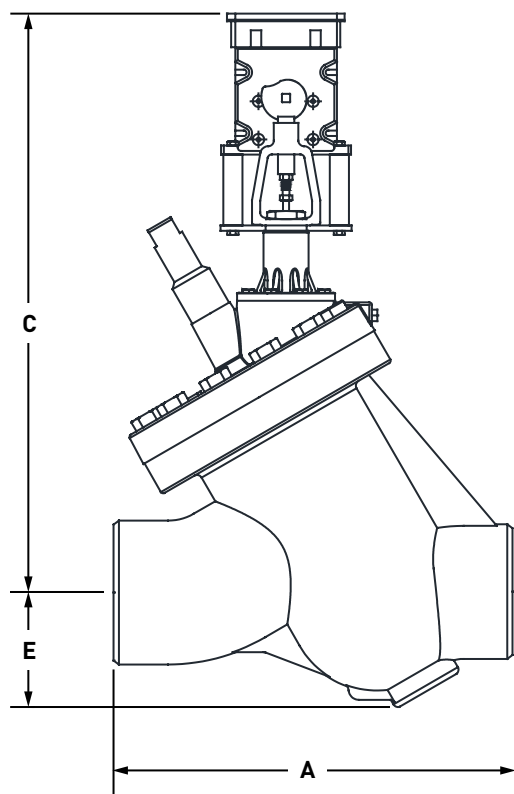
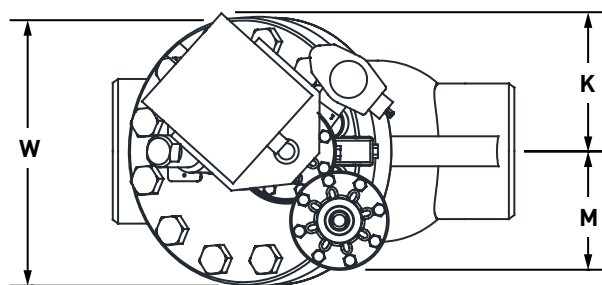
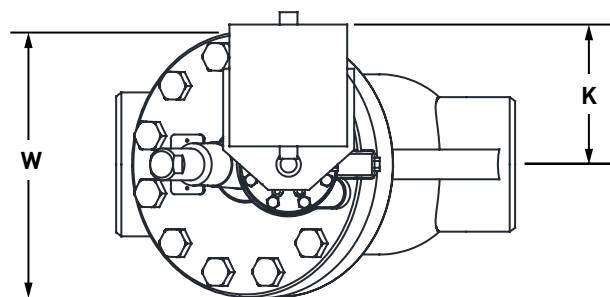

Dimensional Diagram: A4WM Electrically Compensated Inlet Pressure Regulator

Dimensional Diagram: A4WDM Electrically Compensated Dual Inlet Pressure Regulator

Port Size		A		C*		D*		E		K		M		W	
mm	inch	mm	inch	mm	inch	mm	inch	mm	inch	mm	inch	mm	inch	mm	inch
125	5	381	15.0	633	24.9	668	26.3	114	4.5	175	6.9	140	5.5	267	10.5
150	6	483	19.0	686	27.0	721	28.4	152	6.0	175	6.9	140	5.5	318	12.5
200	8	622	24.5	767	30.2	800	31.5	197	7.8	175	6.9	140	5.5	381	15.0

Valve body is wider than adapter for 125mm (5") A4W; Adapter wider than body for 150mm (6") & 200mm (8") A4W
 * Allow 75mm (3") overhead clearance for access to adjusting stem.

Appendix B

A4 Adaptomode® Series Pressure Regulators

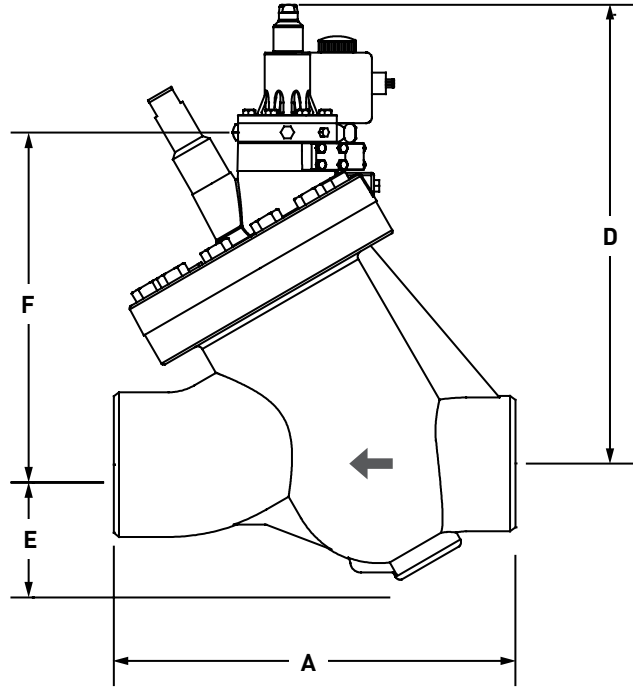
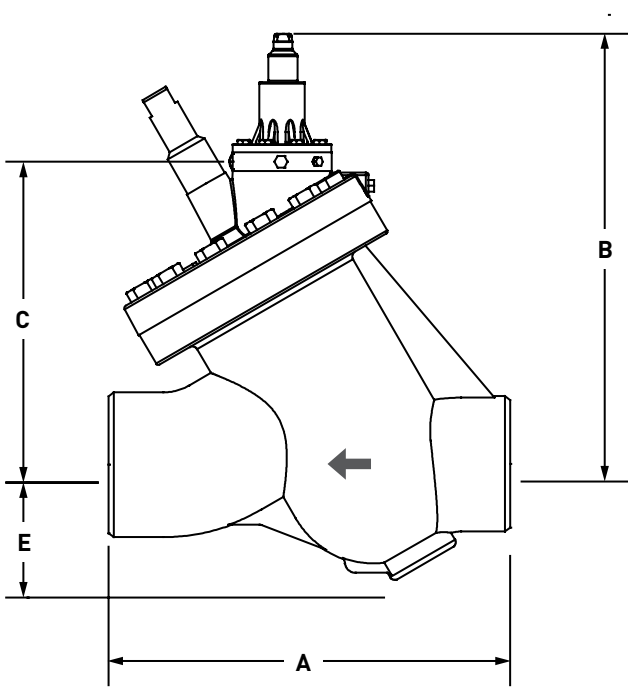
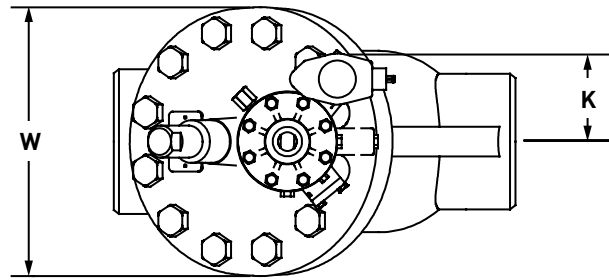
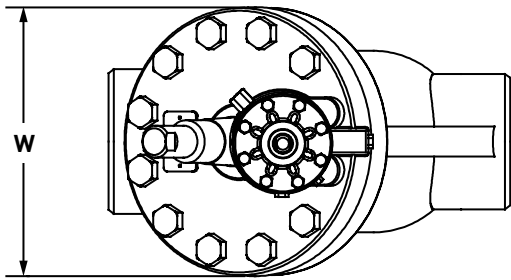

Dimensional Diagram: A4WOE Outlet Pressure Regulator

Dimensional Diagram: A4WOES Outlet Pressure Regulator

Port Size		A		B		C		D		E		F		K		W	
mm	inch	mm	inch	mm	inch	mm	inch	mm	inch	mm	inch	mm	inch	mm	inch	mm	inch
125	5	381	15.0	460	18.1	305	12.0	495	19.5	114	4.5	340	13.4	100	3.9	267	10.5
150	6	483	19.0	536	21.1	381	15.0	571	22.4	152	6.0	416	16.4	100	3.9	318	12.5
200	8	622	24.5	594	23.4	438	17.2	629	24.8	197	7.8	473	18.6	100	3.9	381	15.0

Valve body is wider than adapter for 125mm (5") A4W; Adapter wider than body for 150mm (6") & 200mm (8") A4W
 * Allow 75mm (3") overhead clearance for access to adjusting stem.

Appendix B

Compact Pressure Regulator

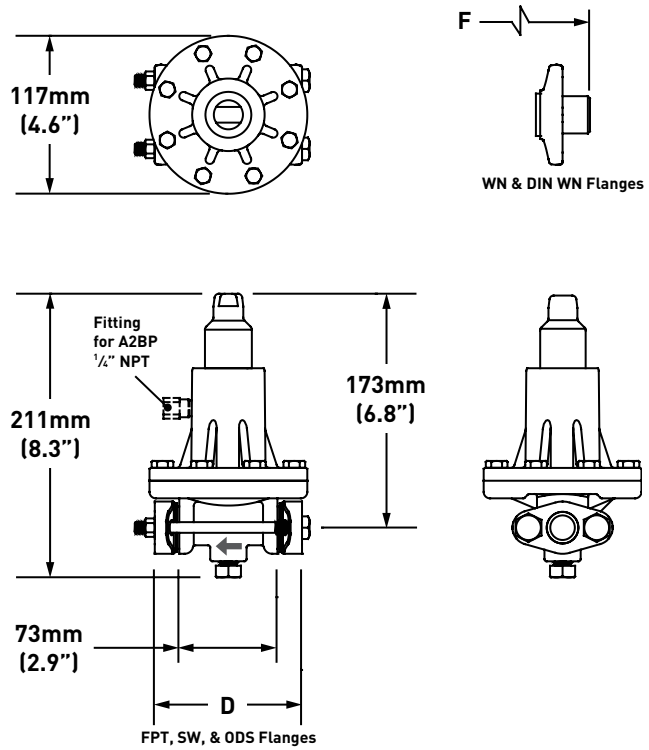

Dimensional Diagram: A2A, A2B, A2CK Pressure Regulators

Flange Port Size	D		F				
	FPT*, SW, ODS		WN		DIN WN		
	mm	inch	mm	inch	Connection	mm	inch
1/4"	112	4.4	131	5.17	13mm	131	5.17
3/6"					20mm		
1/2"							
3/4"							

Solenoid Valves

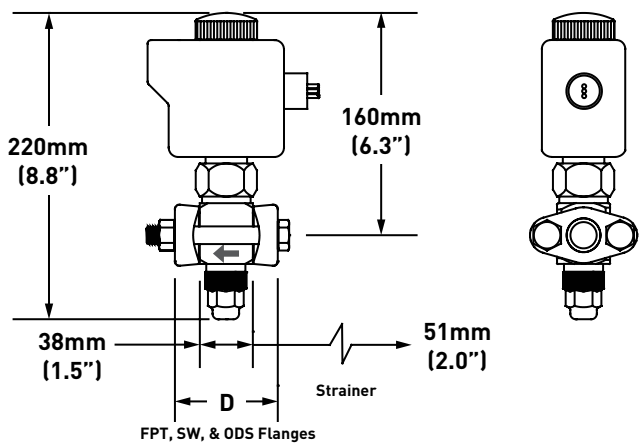
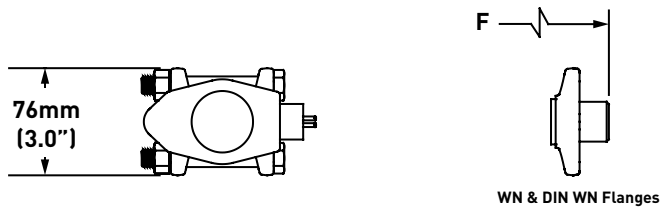

Dimensional Diagram: S6N, S8F Solenoid Valves

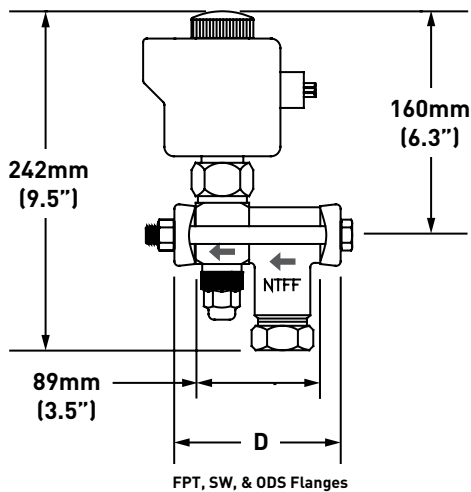

Dimensional Diagram: S6N, S8F Solenoid Valves with RSF Strainer

Appendix B

Valve	Flange Port Size	D		F				
		FPT*, SW, ODS		WN		DIN WN		
		mm	inch	mm	inch	Connection	mm	inch
S6N S8F	1/4"	76	3.0	96	3.77	13mm	96	3.77
	3/8"							
	1/2"					20mm		
	3/4"							

Valve	Flange Port Size	D		F				
		FPT*, SW, ODS		WN		DIN WN		
		mm	inch	mm	inch	Connection	mm	inch
S6N S8F with RSF	1/4"	127	5.0	146	5.77	13mm	146	5.77
	3/8"							
	1/2"					20mm		
	3/4"							

Allow 100mm (4") overhead clearance for removal of coil.

Allow 25mm (1") below valve to access manual opening stem.

When closed coupled with an 1/2" RSF strainer allow 82mm (3.25") below the strainer to access and replace strainer basket.

Solenoid Valves

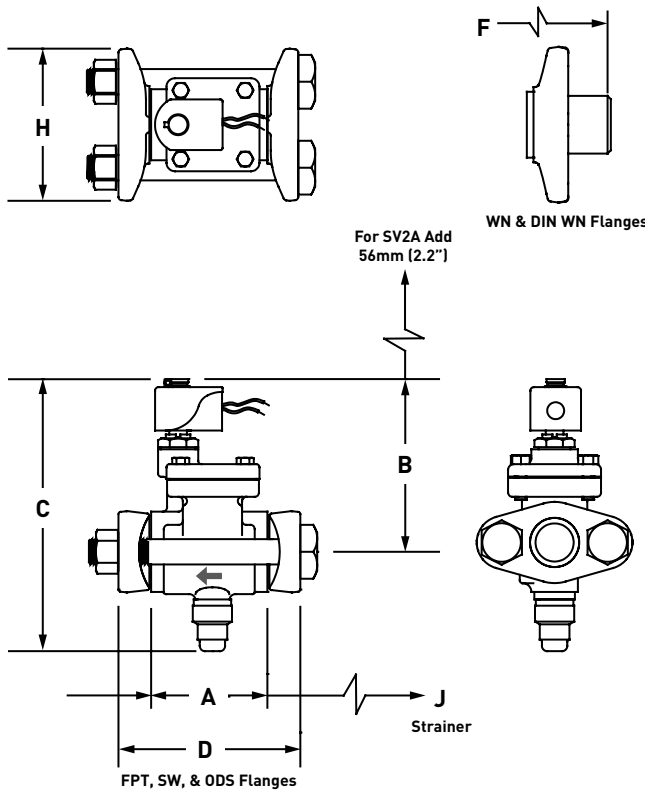

Dimensional Diagram: SV2 Solenoid Valves

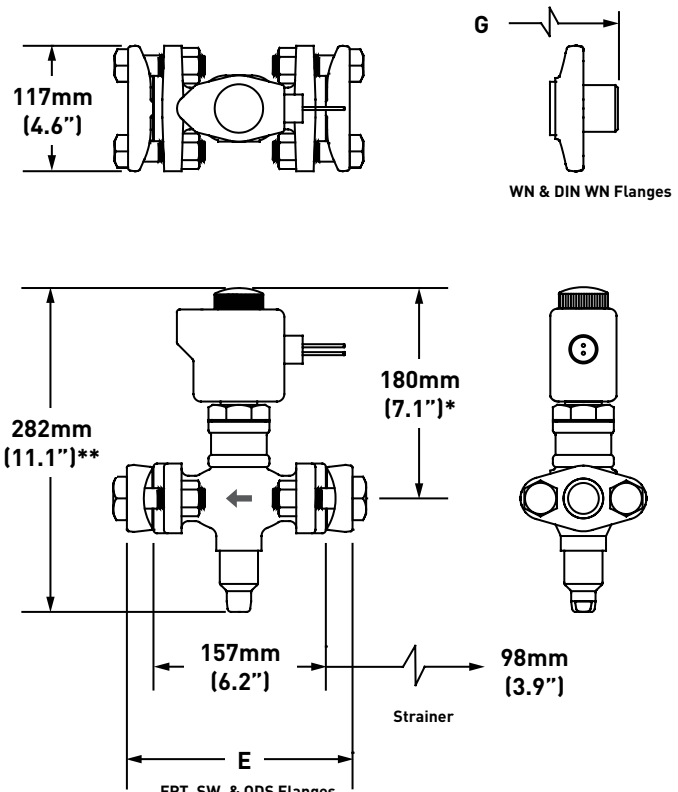

Dimensional Diagram: S7A Solenoid Valves

Port Size		A		B*		C**		H		J	
mm	inch	mm	inch	mm	inch	mm	inch	mm	inch	mm	inch
13	1/2	58	2.3	99	3.9	170	6.7	76	3.0	97	3.8
20 -25	3/4 - 1	86	3.4	124	4.9	203	8.0	117	4.6	150	5.9
32	1 1/4	150	5.9	130	5.1	218	8.6	97	3.8	178	7.0

Port Size		D						F									
		FPT*, SW			ODS			WN			DIN WN						
mm	inch	Connection	mm	inch	Connection	mm	inch	Connection	mm	inch	Connection	mm	inch				
13	1/2	1/4"	97	3.8	1/2"	97	3.8	1/4"	117	4.6	13mm	122	4.8				
		3/8"						20mm									
		1/2"						20mm									
		3/4"						20mm									
20 - 25	3/4 - 1	3/4"	140	5.5	7/8"	140	5.5	3/4"	170	6.7	20mm	178	7.0				
		1"			1 1/8"			1"			183			7.2	25mm	183	7.2
		1 1/4"			1 3/8"			1 1/4"			272			10.7	32mm	251	9.9
32	1 1/4	1 1/4"	203	8.0	1 5/8"	203	8.0	1 1/4"	272	10.7	32mm	251	9.9				
		1 1/2"						1 1/2"			259			10.2	38mm	259	10.2

Port Size		E						G					
		FPT*, SW			ODS			WN			DIN WN		
mm	inch	Connection	mm	inch	Connection	mm	inch	Connection	mm	inch	Connection	mm	inch
20 - 25	3/4 - 1	3/4"	211	8.3	7/8"	211	8.3	3/4"	246	9.7	20mm	249	9.8
		1"			1"			254			10.0		
		1 1/4"			1 3/8"			1 1/4"	254	10.0	32mm	254	10.0

*Allow 38mm (1 1/2") above valve for removal of coil.
 ** Allow 25mm (1") below valve to operate manual opening stem

Solenoid Valves

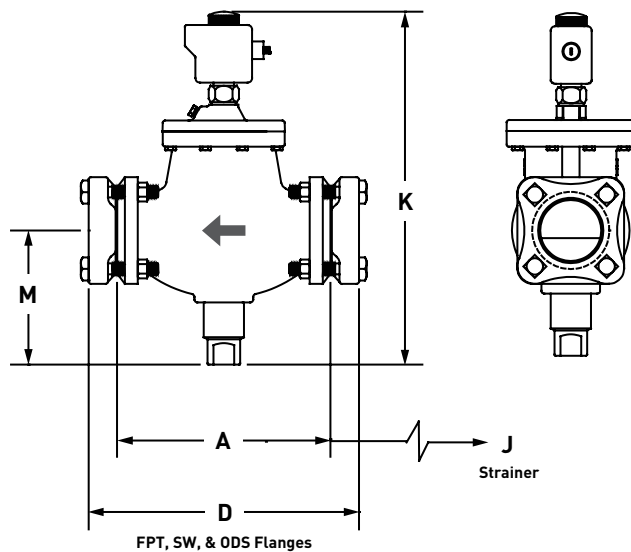
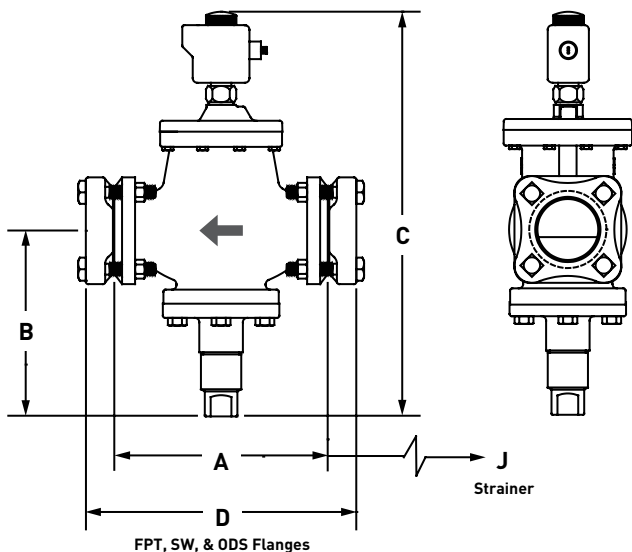
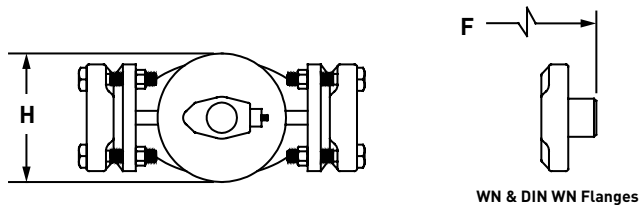
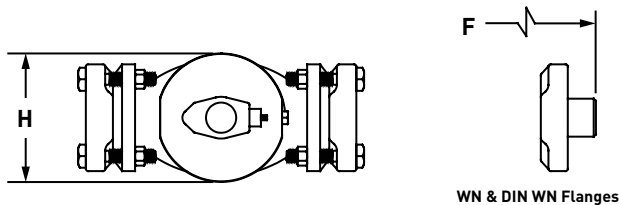

Dimensional Diagram: S4A Solenoid Valves

Dimensional Diagram: S5A Solenoid Valves

Port Size		A		B*		C**		H		J		K**		M	
mm	inch	mm	inch	mm	inch	mm	inch	mm	inch	mm	inch	mm	inch	mm	inch
20 - 25	3/4 - 1	164	6.2	147	5.8	376	14.8	117	4.6	150	5.9	-	-	-	-
32	1 1/4	203	8.0	160	6.3	394	15.5	117	4.6	178	7.0	348	13.7	117	4.6
40 - 50	1 5/8 - 2	251	9.9	175	6.9	442	17.4	140	5.5	251	9.9	411	16.2	127	5.0
65	2 1/2	252	9.9	180	7.1	467	18.4	159	6.2	315	12.4	437	17.2	137	5.4
75	3	311	12.2	272	10.7	579	22.8	176	7.0	315	12.4	511	20.1	198	7.8
100	4	359	14.1	292	11.5	645	25.4	222	8.9	363	14.3	-	-	-	-

* Allow 25mm (1") below valve to operate manual opening stem

**Allow 38mm (1 1/2") above valve for removal of coil.

Port Size		D						F					
		FPT*, SW			ODS			WN			DIN WN		
mm	inch	Connection	mm	inch	Connection	mm	inch	Connection	mm	inch	Connection	mm	inch
20 - 25	3/4 - 1	3/4"	211	8.3	7/8"	211	8.3	3/4"	246	9.7	20mm	248	9.8
		1"			1 1/8"			1"	254	10.0	25mm	255	10.0
		1 1/4"			1 3/8"			1 1/4"		32mm			
32	1 1/4	1 1/4"	254	10.0	1 5/8"	254	10.0	1 1/4"	325	12.8	32mm	304	12.0
		1 1/2"			1 1/2"			312	12.3	38mm	313	12.3	
40 - 50	1 5/8 - 2	1 1/2"	307	12.1	2 1/8"	307	12.1	1 1/2"	366	14.4	38mm	364	14.4
		2"			2 5/8"			2"	378	14.9	50mm	371	14.6
65	2 1/2	2 1/2"	318	12.5	2 5/8"	318	12.5	2 1/2"	389	15.3	65mm	388	15.3
		3"			3 1/8"			3"	406	16.0			
75	3	3"	376	14.8	3 1/8"	376	14.8	3"	465	18.3	75mm	465	18.3
		3 5/8"											
100	4	4"	432	17.0	4 1/8"	432	17.0	4"	551	21.7	100mm	552	21.7

* FPT flanges are only available in 20 - 50mm (3/4" - 2")

Dual Position Solenoid Valves

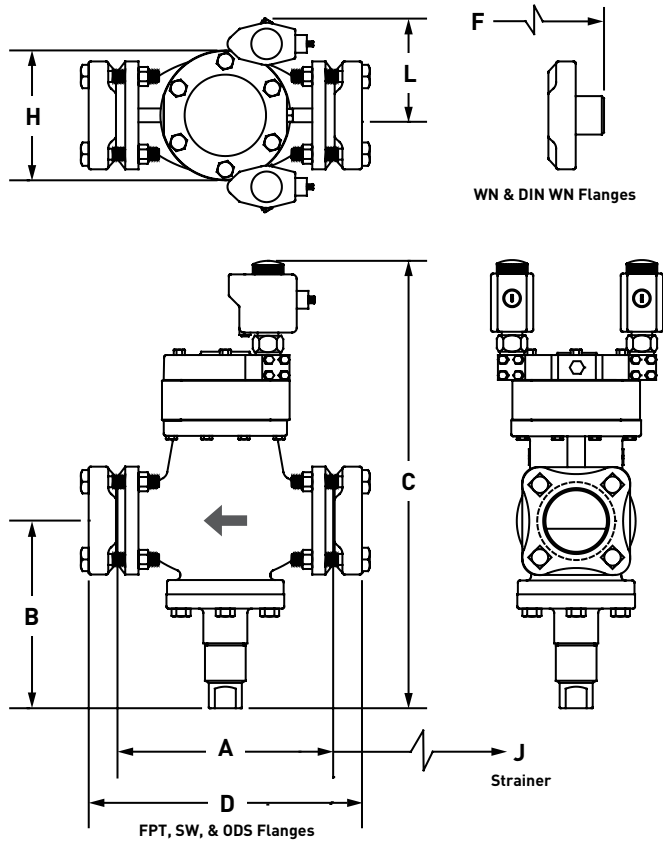

Dimensional Diagram: S4AD Dual Position Solenoid Valves

Port Size		A		B*		C**		H		J		L	
mm	inch	mm	inch	mm	inch	mm	inch	mm	inch	mm	inch	mm	inch
20 -25	¾ - 1	164	6.2	147	5.8	399	15.7	117	4.6	150	5.9	86.4	3.4
32	1¼	203	8.0	160	6.3	422	16.6	117	4.6	178	7.0	107	4.2
40 - 50	1½ - 2	251	9.9	175	6.9	483	19.0	140	5.5	251	9.9	117	4.6
65	2½	252	9.9	180	7.1	508	20.0	159	6.2	315	12.4	124	4.9
75	3	311	12.2	272	10.7	617	24.3	176	7.0	315	12.4	142	5.6
100	4	359	14.1	292	11.5	699	27.5	222	8.9	363	14.3	158	6.2

* Allow 25mm (1") below valve to operate manual opening stem

**Allow 38mm (1½") above valve for removal of coil.

Port Size		D						F					
		FPT*, SW			ODS			WN			DIN WN		
mm	inch	Connection	mm	inch	Connection	mm	inch	Connection	mm	inch	Connection	mm	inch
20 - 25	¾ - 1	¾"	211	8.3	7/8"	211	8.3	¾"	246	9.7	20mm	255	10.0
		1"			1 1/8"			1"			25mm		
		1¼"			1 3/8"			1¼"			32mm		
32	1¼	1¼"	254	10.0	1 5/8"	254	10.0	1¼"	325	12.8	32mm	313	12.3
		1½"			1 1/2"			38mm					
40 - 50	1½ - 2	1½"	307	12.1	2 1/8"	307	12.1	1½"	366	14.4	38mm	371	14.6
		2"			2 5/8"			2"			50mm		
65	2½	2½"	318	12.5	2 5/8"	318	12.5	2½"	389	15.3	65mm	388	15.3
		3"			3 1/8"			3"			406		
75	3	3"	376	14.8	3 1/8"	376	14.8	3"	465	18.3	75mm	465	18.3
					3 5/8"								
100	4	4"	432	17.0	4 1/8"	432	17.0	4"	551	21.7	100mm	552	21.7

* FPT flanges are only available in 20 - 50mm (¾" - 2")

Solenoid Valves / Gas Powered Suction Stop Valves

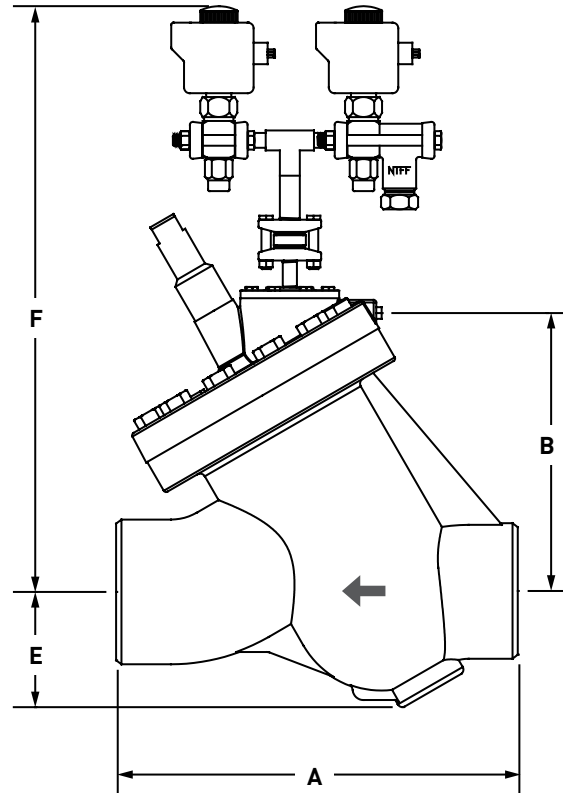
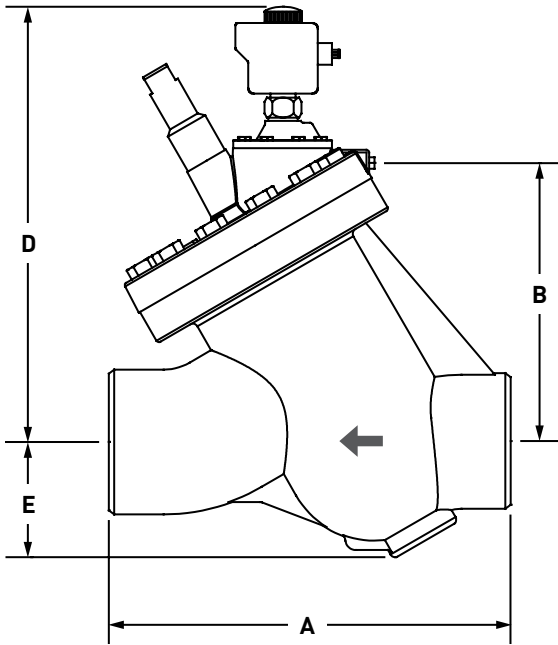
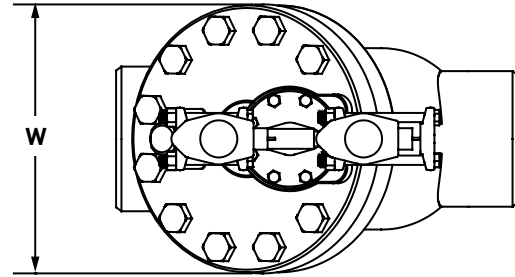
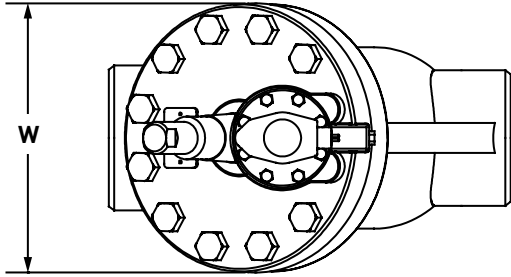

Dimensional Diagram: S4W Solenoid Valves

Dimensional Diagram: S9W Gas Powered Suction Stop Valves

Port Size		A**		B		C		D*		E		F**		W	
mm	inch	mm	inch	mm	inch	mm	inch	mm	inch	mm	inch	mm	inch	mm	inch
125	5	451	17.8	273	10.7	315	12.4	438	17.2	114	4.5	711	28.0	267	10.5
150	6	527	20.8	349	13.7	391	15.4	514	20.2	152	6.0	825	32.5	318	12.5
200	8	584	23.0	406	16.0	448	17.6	572	22.5	197	7.8	927	36.5	381	15.0

Valve body is wider than adapter for 125mm (5") A4W; Adapter wider than body for 150mm (6") & 200mm (8") A4W

* Allow 75mm (3") overhead clearance for access to adjusting stem.

** Allow 100mm (4") overhead clearance for coil or seal cap removal.

Gas Powered Suction Stop Valves

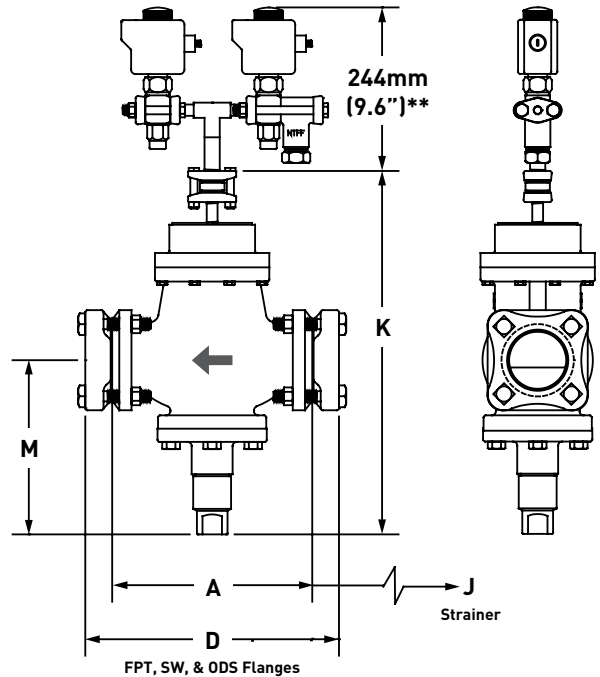
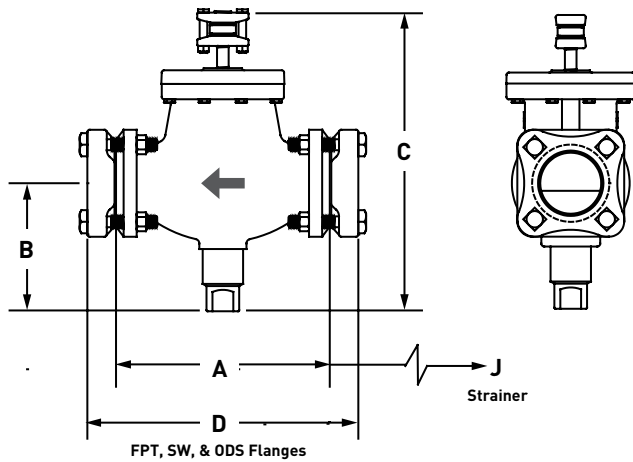
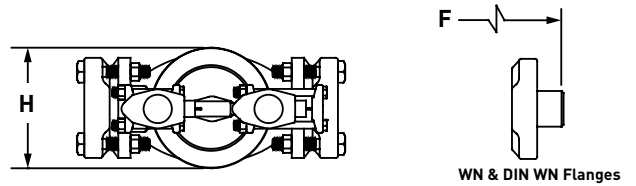
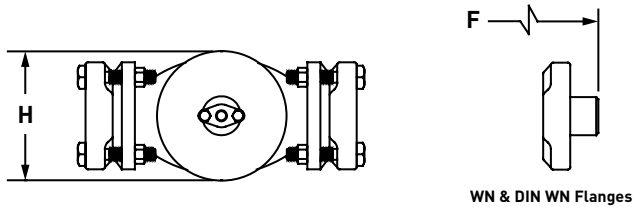

Dimensional Diagram: CK-2 Gas Powered Suction Stop Valves

Dimensional Diagram: S9A Gas Powered Suction Stop Valves

Port Size		A		B*		C		H		J		K*		M	
mm	inch	mm	inch	mm	inch	mm	inch	mm	inch	mm	inch	mm	inch	mm	inch
32	1¼	203	8.0	122	4.8	312	12.3	117	4.6	178	7.0	-	-	-	-
40	1½	251	9.9	140	5.5	361	14.2	140	5.5	251	9.9	-	-	-	-
50	2	251	9.9	140	5.5	161	14.2	140	5.5	251	9.9	429	16.9	175	6.9
65	2½	252	9.9	142	5.6	396	15.6	159	6.2	315	12.4	455	17.9	180	7.1
75	3	311	12.2	216	8.5	475	18.7	176	7.0	315	12.4	569	22.4	272	10.7
100	4	359	14.1	219	8.6	518	20.4	222	8.9	363	14.3	615	24.2	292	11.5

* Allow 25mm (1") below valve to operate manual opening stem

**Allow 38mm (1½") above valve for removal of coil.

Port Size		D						F					
		FPT*, SW			ODS			WN			DIN WN		
mm	inch	Connection	mm	inch	Connection	mm	inch	Connection	mm	inch	Connection	mm	inch
32	1¼	1¼"	254	10.0	1½"	254	10.0	1¼"	325	12.8	32mm	304	12.0
		1½"			312			12.3	38mm	313	12.3		
40 - 50	1½ - 2	1½"	307	12.1	2½"	307	12.1	1½"	366	14.4	38mm	364	14.4
		2"			378			14.9	50mm	371	14.6		
65	2½	2½"	318	12.5	2⅝"	318	12.5	2½"	389	15.3	65mm	388	15.3
		3"			406			16.0					
75	3	3"	376	14.8	3⅞"	376	14.8	3"	465	18.3	75mm	465	18.3
					3⅝"								
100	4	4"	432	17.0	4⅞"	432	17.0	4"	551	21.7	100mm	552	21.7

* FPT flanges are only available in 32 - 50mm (1¼" - 2")

Appendix B

Gas Powered Suction Stop Valves

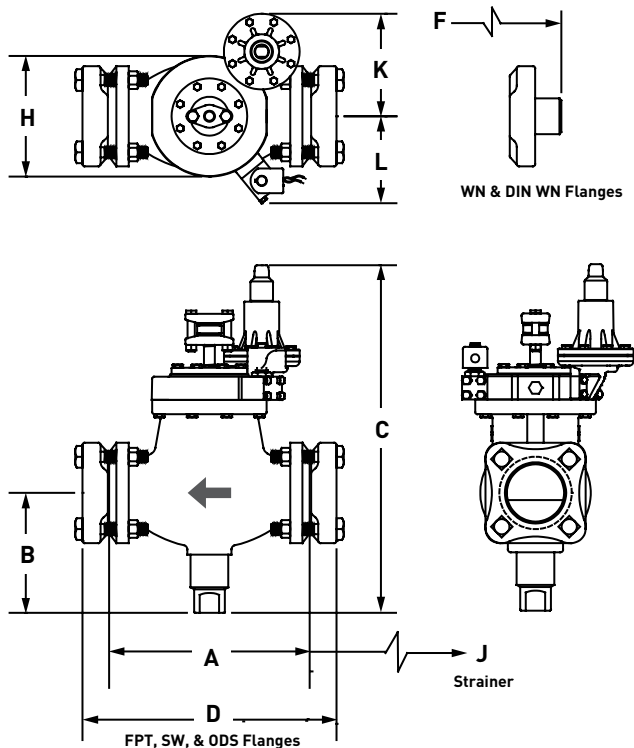

Dimensional Diagram: CK-5 Gas Powered Suction Stop Valves

Port Size		A		B*		C		H		J		K		L	
mm	inch	mm	inch	mm	inch	mm	inch	mm	inch	mm	inch	mm	inch	mm	inch
20 - 25	3/4 - 1	164	6.2	147	5.8	-	-	117	4.6	150	5.9	-	-	-	-
32	1 1/4	203	8.0	160	6.3	447	17.6	117	4.6	178	7.0	137	5.4	112	4.4
40 - 50	1 5/8 - 2	251	9.9	175	6.9	500	19.7	140	5.5	251	9.9	140	5.5	117	4.6
65	2 1/2	252	9.9	180	7.1	513	20.2	159	6.2	315	12.4	150	5.9	124	4.9
75	3	311	12.2	272	10.7	632	24.9	176	7.0	315	12.4	168	6.6	142	5.6
100	4	359	14.1	292	11.5	686	27.0	222	8.9	363	14.3	196	7.7	158	6.2

* Allow 25mm (1") below valve to operate manual opening stem

Port Size		D						F					
		FPT*, SW			ODS			WN			DIN WN		
mm	inch	Connection	mm	inch	Connection	mm	inch	Connection	mm	inch	Connection	mm	inch
20 - 25	3/4 - 1	3/4"	211	8.3	7/8"	211	8.3	3/4"	246	9.7	20mm	255	10.0
		1"			1 1/8"			1"			25mm		
		1 1/4"			1 3/8"			1 1/4"			32mm		
32	1 1/4	1 1/4"	254	10.0	1 5/8"	254	10.0	1 1/4"	325	12.8	32mm	304	12.0
		1 1/2"			1 5/8"			1 1/2"			38mm		
40 - 50	1 5/8 - 2	1 1/2"	307	12.1	2 1/8"	307	12.1	1 1/2"	366	14.4	38mm	364	14.4
		2"			2 5/8"			2"			50mm		
65	2 1/2	2 1/2"	318	12.5	2 5/8"	318	12.5	2 1/2"	389	15.3	65mm	388	15.3
		3"			3 1/8"			3"			406		
75	3	3"	376	14.8	3 1/8"	376	14.8	3"	465	18.3	75mm	465	18.3
					3 5/8"								
100	4	4"	432	17.0	4 1/8"	432	17.0	4"	551	21.7	100mm	552	21.7

* FPT flanges are only available in 20 - 50mm (3/4" - 2")

Gas Powered Suction Stop Valves

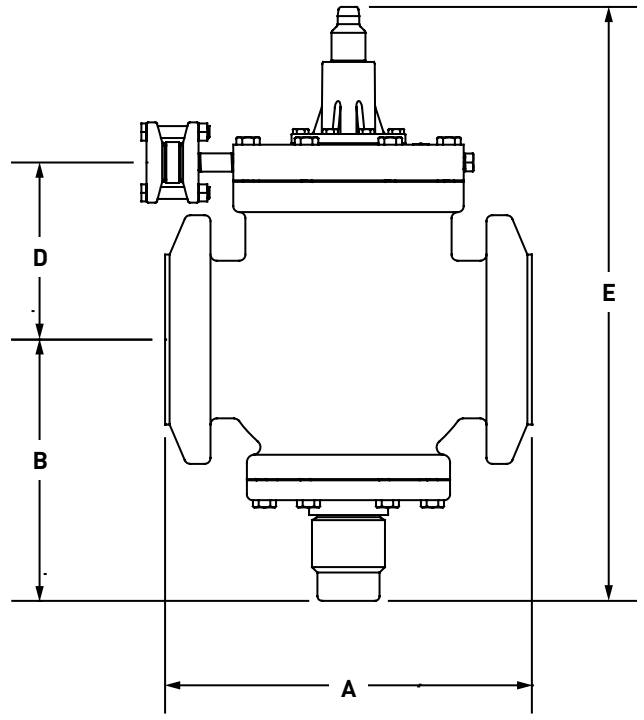
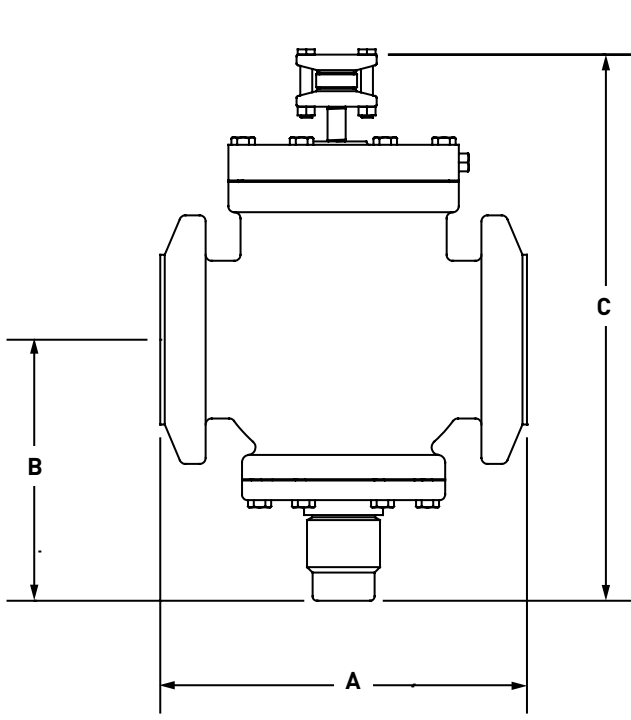
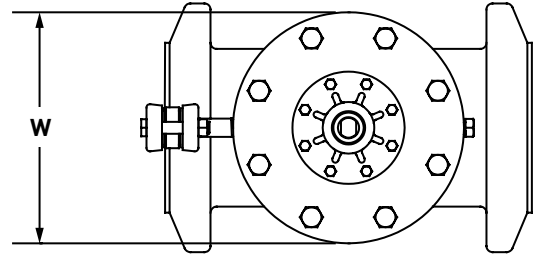
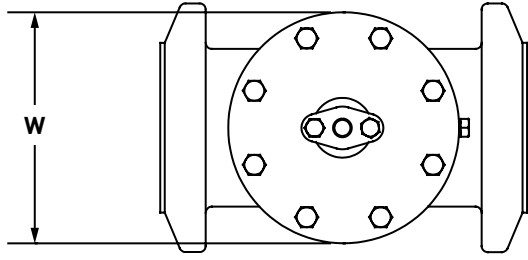

Dimensional Diagram: CK-2 Gas Powered Suction Stop Valves

Dimensional Diagram: CK-5 Gas Powered Suction Stop Valves

Port Size		A*		B*		C		D		E		W	
mm	inch	mm	inch	mm	inch	mm	inch	mm	inch	mm	inch	mm	inch
125	5	381	15.0	297	11.7	589	23.2	213	8.4	589	23.2	229	9.0
150	6	513	20.2	356	14.0	627	24.7	196	7.7	681	26.8	295	11.6

* Allow 75mm (3") overhead clearance for access to adjusting stem.
 ** Allow 100mm (4") overhead clearance for coil or seal cap removal.

Dual Position Gas Powered Suction Stop Valves

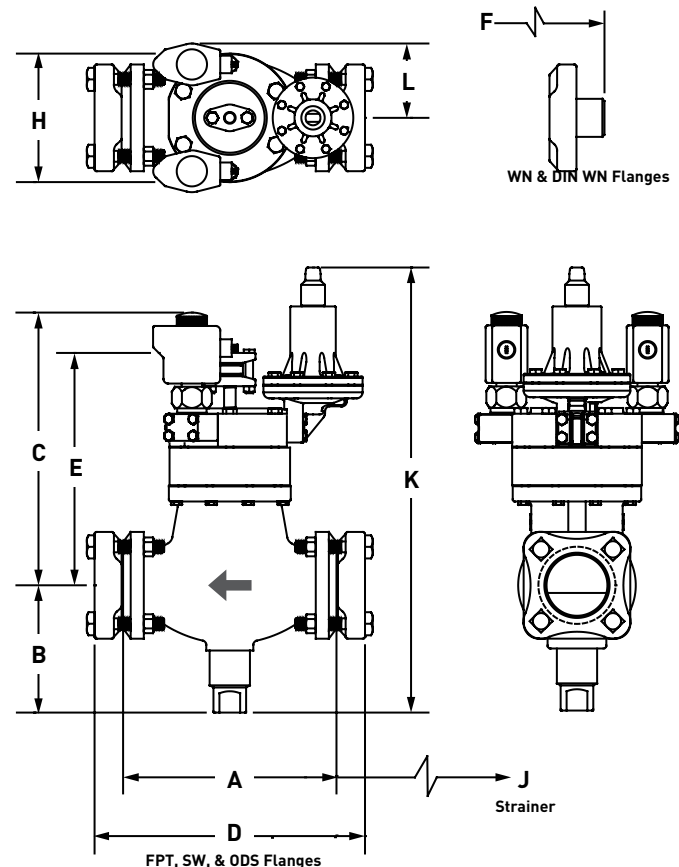
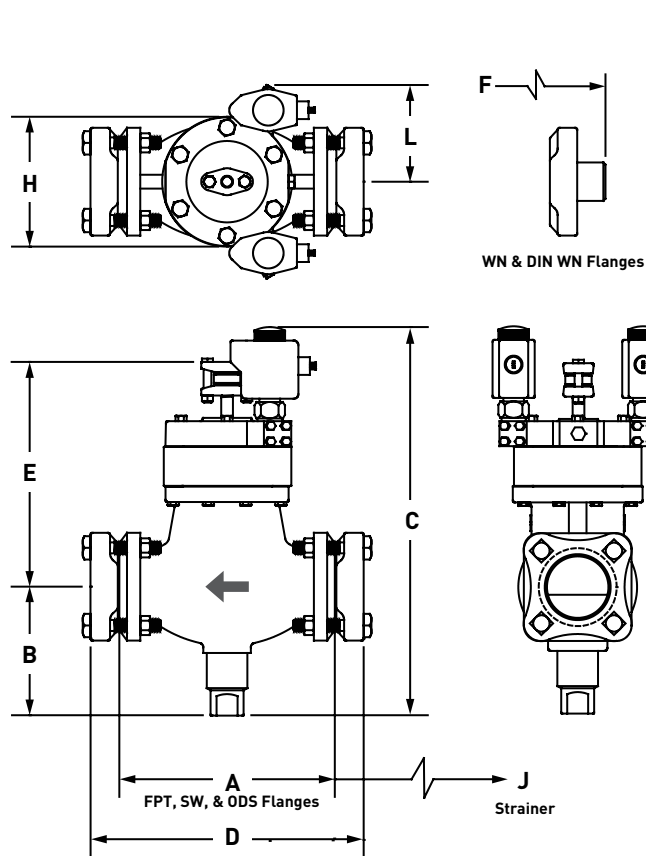

Dimensional Diagram: CK-2D Dual Position Gas Powered Suction Stop Valves

Dimensional Diagram: CK-6D Dual Position Gas Powered Suction Stop Valves

Port Size		A		B*		C**		E		H		J		K		L	
mm	inch	mm	inch	mm	inch	mm	inch	mm	inch	mm	inch	mm	inch	mm	inch	mm	inch
50	2	251	9.9	140	5.5	472	18.6	272	10.7	140	5.5	251	9.9	500	19.7	117	4.6
65	2½	252	9.9	142	5.6	500	19.7	297	11.7	159	6.2	315	12.4	528	20.8	124	4.9
75	3	311	12.2	216	8.5	597	23.5	330	13.0	176	7.0	315	12.4	625	24.6	142	5.6
100	4	359	14.1	219	8.6	652	25.7	361	14.2	222	8.9	363	14.3	681	26.8	158	6.2

* Allow 25mm (1") below valve to operate manual opening stem
 **Allow 38mm (1½") above valve for removal of coil.

Port Size		D						F					
		FPT*, SW			ODS			WN			DIN WN		
mm	inch	Connection	mm	inch	Connection	mm	inch	Connection	mm	inch	Connection	mm	inch
50	2	1½"	307	12.1	2½"	307	12.1	1½"	366	14.4	38mm	364	14.4
		2"			2⅝"			2"			50mm		
65	2½	2½"	318	12.5	2⅝"	318	12.5	2½"	389	15.3	65mm	388	15.3
		3"			3⅜"			3"					
75	3	3"	376	14.8	3⅜"	376	14.8	3"	465	18.3	75mm	465	18.3
					3⅝"								
100	4	4"	432	17.0	4⅞"	432	17.0	4"	551	21.7	100mm	552	21.7

* FPT flanges are only available in 50mm (2")

Check Valves

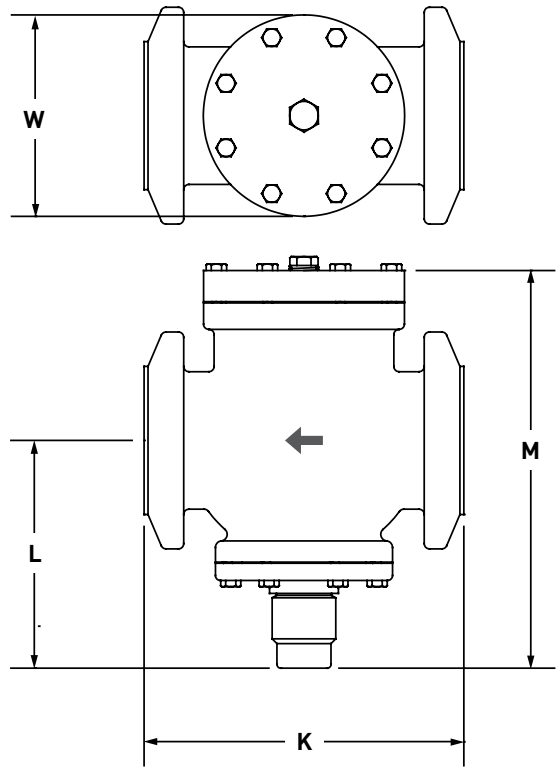
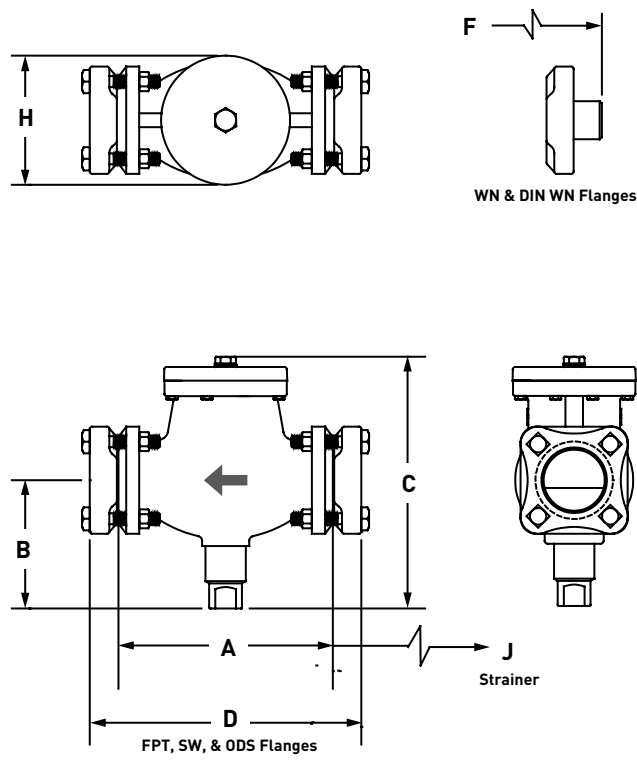

Dimensional Diagram: CK-1 Check Valves

Dimensional Diagram: CK-1 Check Valves

Port Size		A		B*		C		H		J		K		L		M		W	
mm	inch	mm	inch	mm	inch	mm	inch	mm	inch	mm	inch	mm	inch	mm	inch	mm	inch	mm	inch
20 - 25	3/4 - 1	164	6.2	147	5.8	191	7.5	117	4.6	150	5.9	-	-	-	-	-	-	-	-
32	1 1/4	203	8.0	160	6.3	218	8.6	117	4.6	178	7.0	-	-	-	-	-	-	-	-
40 - 50	1 5/8 - 2	251	9.9	175	6.9	269	10.6	140	5.5	251	9.9	-	-	-	-	-	-	-	-
65	2 1/2	252	9.9	180	7.1	302	11.9	159	6.2	315	12.4	-	-	-	-	-	-	-	-
75	3	311	12.2	272	10.7	384	15.1	176	7.0	315	12.4	-	-	-	-	-	-	-	-
100	4	359	14.1	292	11.5	427	16.8	222	8.9	363	14.3	-	-	-	-	-	-	-	-
125	5	-	-	-	-	-	-	-	-	-	-	381	15.0	297	11.7	495	19.5	229	9.0
150	6	-	-	-	-	-	-	-	-	-	-	513	20.2	356	14.0	536	21.1	295	11.6

* Allow 25mm (1") below valve to operate manual opening stem

Port Size		D						F					
		FPT*, SW			ODS			WN			DIN WN		
mm	inch	Connection	mm	inch	Connection	mm	inch	Connection	mm	inch	Connection	mm	inch
20 - 25	3/4 - 1	3/4"	211	8.3	7/8"	211	8.3	3/4"	246	9.7	20mm	248	9.8
		1"			254			10.0	25mm	255	10.0		
		1 1/4"						32mm	304	12.0			
32	1 1/4	1 1/4"	254	10.0	1 5/8"	254	10.0	1 1/4"	325	12.8	32mm	304	12.0
		1 1/2"			312			12.3	38mm	313	12.3		
40 - 50	1 5/8 - 2	1 1/2"	307	12.1	2 1/8"	307	12.1	1 1/2"	366	14.4	38mm	364	14.4
		2"			378			14.9	50mm	371	14.6		
65	2 1/2	2 1/2"	318	12.5	2 5/8"	318	12.5	2 1/2"	389	15.3	65mm	388	15.3
		3"			406			16.0					
75	3	3"	376	14.8	3 1/8"	376	14.8	3"	465	18.3	75mm	465	18.3
					3 5/8"								
100	4	4"	432	17.0	4 1/8"	432	17.0	4"	551	21.7	100mm	552	21.7

* FPT flanges are only available in 20 - 50mm (3/4" - 2")

Appendix B

Check Valves

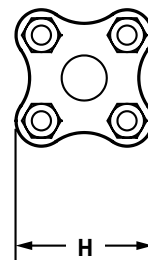
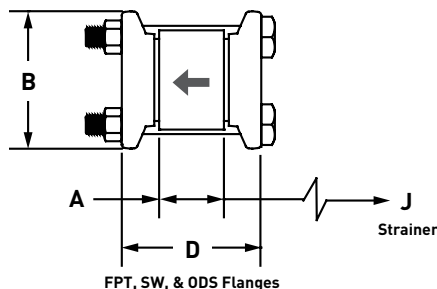
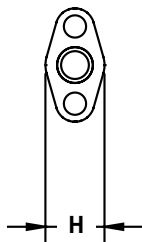
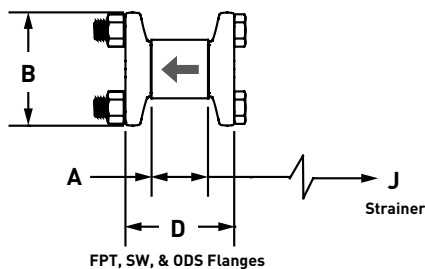
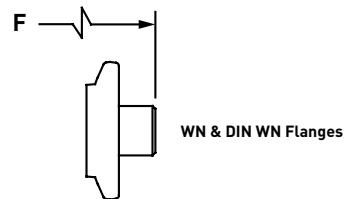
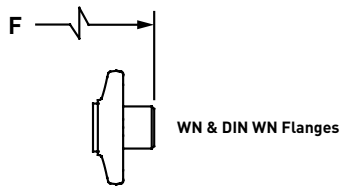

Dimensional Diagram: CK4A Check Valves

Dimensional Diagram: CK4A Check Valves

Port Size		A		B		H		J	
mm	inch	mm	inch	mm	inch	mm	inch	mm	inch
13	1/2	28	1.1	74	2.9	38	1.5	97	3.8
20 -25	3/4 - 1	33	1.3	112	4.4	61	2.4	150	5.9

Port Size		A		B		H		J	
mm	inch	mm	inch	mm	inch	mm	inch	mm	inch
32	1 1/4	51	2.0	97	3.8	97	3.8	178	7.0
50	2	61	2.4	114	4.5	114	4.5	251	9.9
65	2 1/2	71	2.8	147	5.8	147	5.8	315	12.4
75	3	81	3.2	147	5.8	147	5.8	315	12.4
100	4	89	3.5	180	7.1	180	7.1	363	14.3

Appendix B

Port Size		D						F					
		FPT*, SW			ODS			WN			DIN WN		
mm	inch	Connection	mm	inch	Connection	mm	inch	Connection	mm	inch	Connection	mm	inch
13	1/2	1/4"	66	2.6	1/2"	66	2.6	1/4"	86	3.4	13mm	86	3.4
		3/8"						20mm					
		1/2"											
		3/4"											
20 - 25	3/4 - 1	3/4"	86	3.4	7/8"	86	3.4	3/4"	121	4.8	20mm	124	4.9
		1"			130			25mm					
		1 1/4"						32mm					
32	1 1/4	1 1/4"	104	4.1	1 5/8"	104	4.1	1 1/4"	173	6.8	32mm	151	6.0
		1 1/2"						161			6.3		
50	2	1 1/2"	117	4.6	2 1/8"	117	4.6	1 1/2"	174	6.9	38mm	174	6.9
		2"			187			7.4			50mm		
65	2 1/2	2 1/2"	137	5.4	2 5/8"	137	5.4	2 1/2"	207	8.2	65mm	207	8.2
		3"			226			8.9					
75	3	3"	148	5.8	3 1/8"	148	5.8	3"	236	9.3	75mm	236	9.3
					3 5/8"								
100	4	4"	162	6.4	4 1/8"	162	6.4	4"	283	11.1	100mm	283	11.1

* FPT flanges are only available in 13 - 50mm (1/2" - 2")

Check Valves

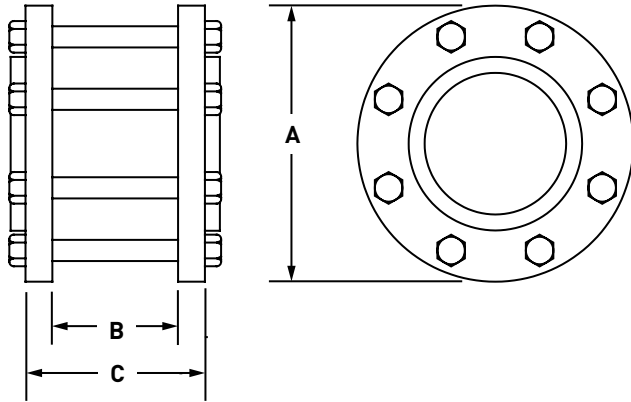

Dimensional Diagram: CK4A Check Valves

Port Size		A		B		C			
mm	inch	mm	inch	mm	inch	SW		WN	
mm	inch	mm	inch	mm	inch	mm	inch	mm	inch
125	5	279	11	104	4.1	150	5.9	196	7.7
150	6	318	13	122	4.8	173	6.8	218	8.6
200	8	381	15	142	5.6	-	-	-	-

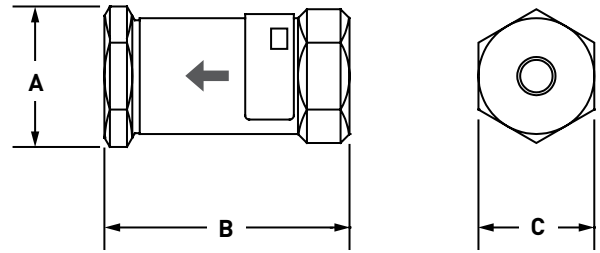

Dimensional Diagram: CK-3 Check Valves

Port Size		A		B		C	
mm	inch	mm	inch	mm	inch	mm	inch
13	1/2	58	2.3	97	3.8	51	2.0
20	3/4	58	2.3	97	3.8	51	2.0
25	1	58	2.3	105	4.2	51	2.0

Strainers

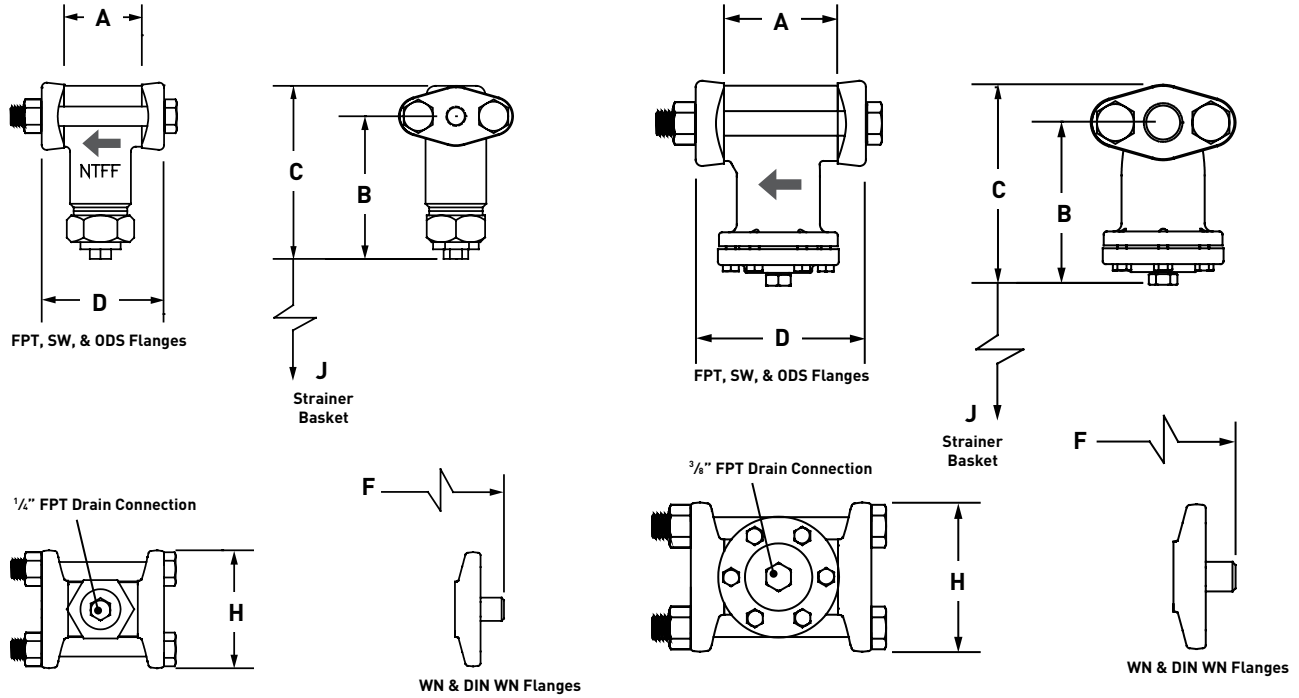

Dimensional Diagram: RSF Strainers

Port Size		A		B		H		J*	
mm	inch	mm	inch	mm	inch	mm	inch	mm	inch
13	1/2	50	2.0	104	4.1	74	2.9	76	3.0

* Space required for removal of strainer screen assembly

Dimensional Diagram: RSF Strainers

Port Size		A		B		H		J*	
mm	inch	mm	inch	mm	inch	mm	inch	mm	inch
25	1	97	3.8	112	4.4	112	4.4	38	5.0

* Space required for removal of strainer screen assembly

Port Size		D						F					
		FPT, SW			ODS			WN			DIN WN		
mm	inch	Connection	mm	inch	Connection	mm	inch	Connection	mm	inch	Connection	mm	inch
13	1/2	1/4"	89	3.5	1/2"	89	3.5	1/4"	108	4.3	13mm	108	4.3
		3/8"						20mm					
		1/2"											
		3/4"											
25	1	3/4"	149	5.9	7/8"	149	5.9	3/4"	184	7.3	20mm	187	7.4
		1"			25mm								
		1 1/8"											
		1 1/4"			194			7.6			32mm		

Appendix B

Strainers

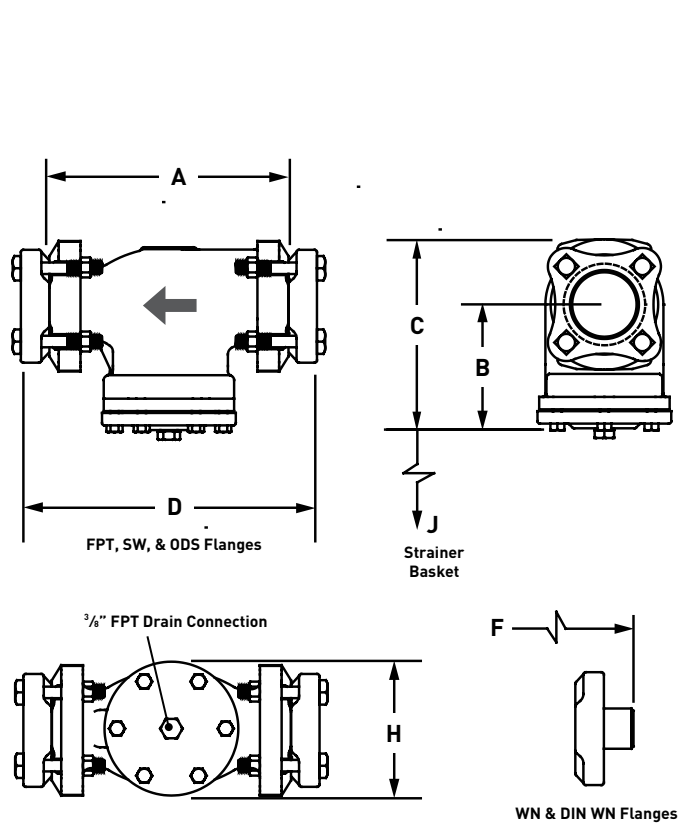

Dimensional Diagram: RSF Strainers

Port Size		A		B		H		J*	
mm	inch	mm	inch	mm	inch	mm	inch	mm	inch
32	1¼	173	6.8	127	5.0	97	3.8	61	5.0
50	2	249	9.8	124	4.9	114	4.5	97	5.0
65	2½	312	12.3	140	5.5	147	5.8	114	5.0
75	3	312	12.3	140	5.5	147	5.8	147	5.0
100	4	330	13.0	178	7.0	180	7.1	147	6.5

* Space required for removal of strainer screen assembly

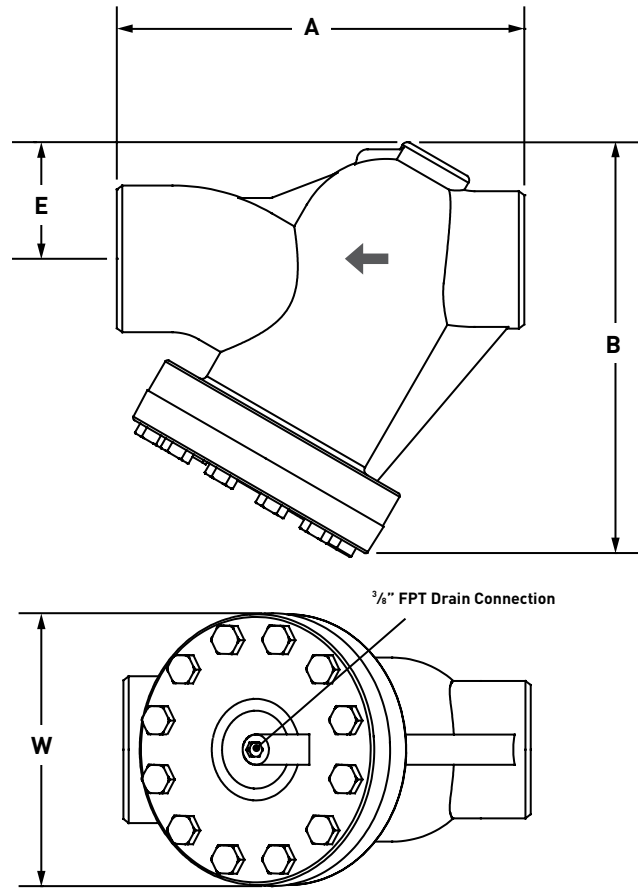

Dimensional Diagram: RSW Strainers

Port Size		A		B*		E		W	
mm	inch	mm	inch	mm	inch	mm	inch	mm	inch
125	5	451	17.8	406	16.0	114	4.5	267	10.5
150	6	527	20.8	483	19.0	152	6.0	318	12.5
200	8	584	23.0	635	25.0	197	7.8	381	15.0

* Allow 254mm (10") below valve for removal of strainer screen assembly

Port Size		D						F					
		FPT*, SW			ODS			WN			DIN WN		
mm	inch	Connection	mm	inch	Connection	mm	inch	Connection	mm	inch	Connection	mm	inch
32	1¼	1¼"	226	8.9	1⅝"	226	8.9	1¼"	295	11.6	32mm	273	10.8
		1½"						283	11.1	38mm	283	11.1	
50	2	1½"	305	12.0	2⅛"	305	12.0	1½"	362	14.3	38mm	362	14.3
		2"			375			14.8	50mm	368	14.5		
65	2½	2½"	379	14.9	2⅝"	379	14.9	2½"	449	17.7	65mm	449	17.7
		3"			468			18.4					
75	3	3"	379	14.9	3⅛"	379	14.9	3"	468	18.4	75mm	468	18.4
					3⅝"								
100	4	4"	404	15.9	4⅞"	404	15.9	4"	524	20.6	100mm	524	20.6

* FPT flanges are only available in 32 - 50mm (1¼" - 2")

Industrial Valve Flanges - Threaded (FPT)

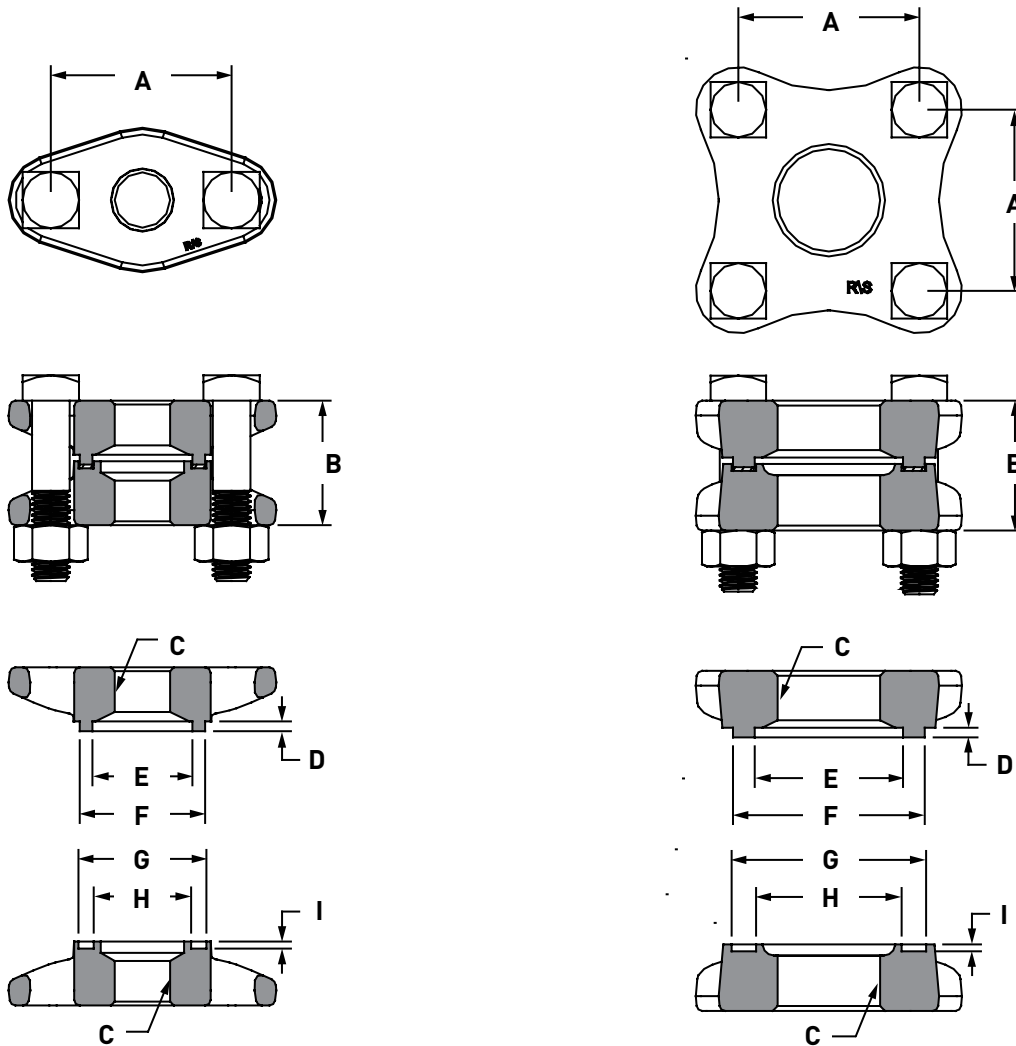

Dimensional Diagram: Threaded (FPT) Flanges

Port Size		Connection (IPS)	Bolt Pattern	A	B	C	Male			Female		
mm	inch						D	E	F	G	H	I
13	1/2	1/4"	2	2.00"	1.50"	1/4"-18 FPT	0.13"	1.00"	1.24"	1.26"	0.99"	0.12"
		3/8"				3/8"-18 FPT						
		1/2"				1/2"-14 FPT						
		3/4"				3/4"-14 FPT						
25	1	3/4"	2	3.05"	2.08"	3/4"-14 FPT	0.16"	1.66"	2.09"	2.13"	1.62"	0.12"
		1"				1"-11 1/2 FPT						
		1 1/4"				1 1/4"-11 1/2 FPT						
32	1 1/4	1 1/4"	4	2.38"	2.08"	1 1/4"-11 1/2 FPT	0.16"	1.85"	2.27"	2.32"	1.80"	0.12"
		1 1/2"				1 1/2"-11 1/2 FPT						
50	2	1 1/2"	4	3.06"	2.20"	1 1/2"-11 1/2 FPT	0.16"	2.51"	3.24"	3.29"	2.46"	0.12"
		2"				2"-11 1/2 FPT						

Industrial Valve Flanges - Socket Weld (SW)

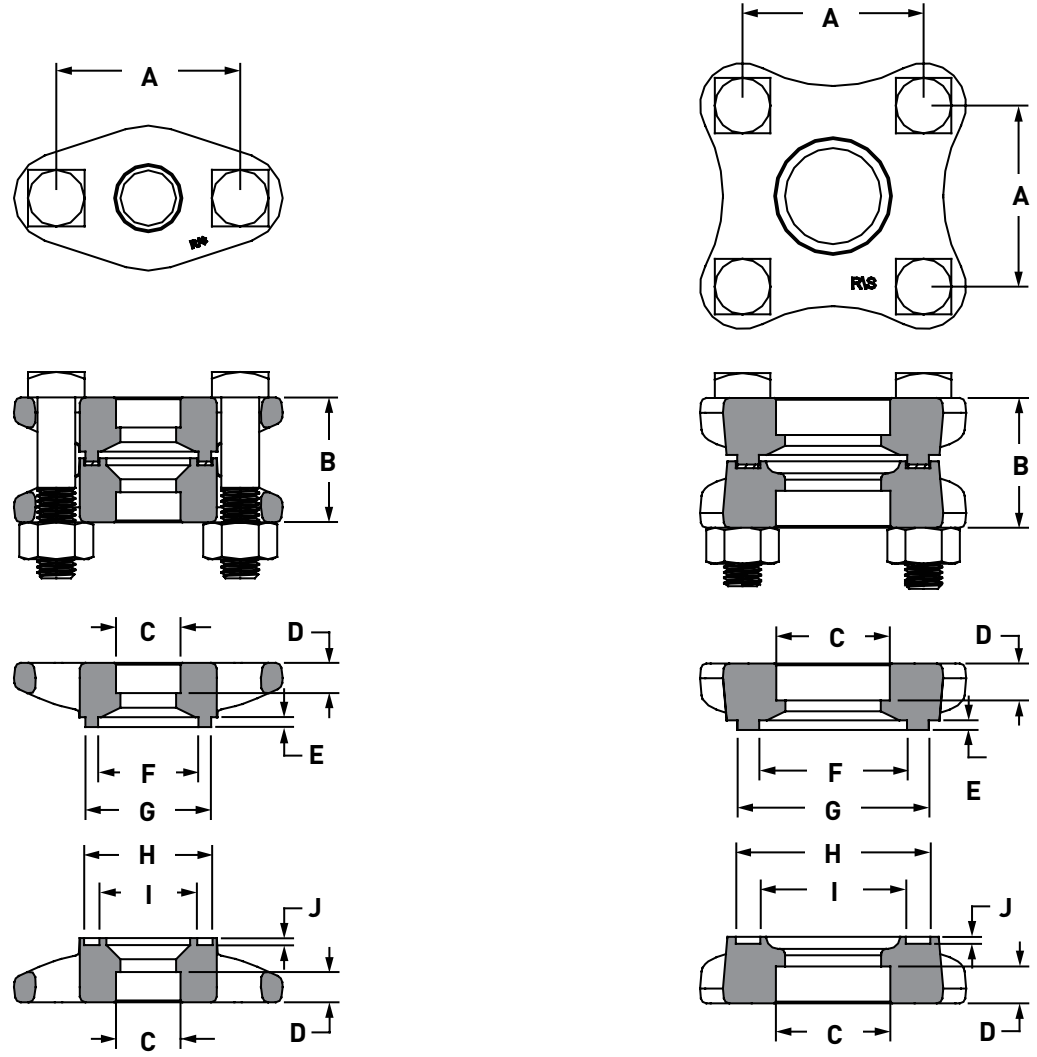

Dimensional Diagram: Socket Weld (SW) Flanges

Port Size		Connection (IPS)	Bolt Pattern	A	B	C	D	Male			Female		
mm	inch							E	F	G	H	I	J
13	1/2	1/4"	2	2.00"	1.50"	0.565"	0.375"	0.13"	1.00"	1.24"	1.26"	0.99"	0.12"
		3/8"				0.700"							
		1/2"				0.865"							
		3/4"				1.075"	0.500"						
25	1	3/4"	2	3.05"	2.08"	1.070"	0.500"	0.16"	1.66"	2.09"	2.13"	1.62"	0.12"
		1"				1.365"							
		1 1/4"				1.705"	0.688"						
32	1 1/4	1 1/4"	4	2.38"	2.08"	1.705"	0.625"	0.16"	1.85"	2.27"	2.32"	1.80"	0.12"
		1 1/2"				1.930"							
50	2	1 1/2"	4	3.06"	2.20"	1.930"	0.625"	0.16"	2.51"	3.24"	3.29"	2.46"	0.12"
		2"				2.445"							
65	2 1/2	2 1/2"	4	4.07"	2.61"	2.945"	0.750"	0.16"	3.00"	3.74"	3.79"	2.96"	0.12"
		3"				3.575"							
75	3	3"	4	4.07"	2.61"	3.575"	0.875"	0.16"	3.63"	4.37"	4.41"	3.59"	0.12"
100	4	4"	4	5.00"	2.89"	4.575"	0.875"	0.16"	4.76"	5.49"	5.54"	4.71"	0.12"

Appendix B

Industrial Valve Flanges - Outside Diameter Sweat (ODS)

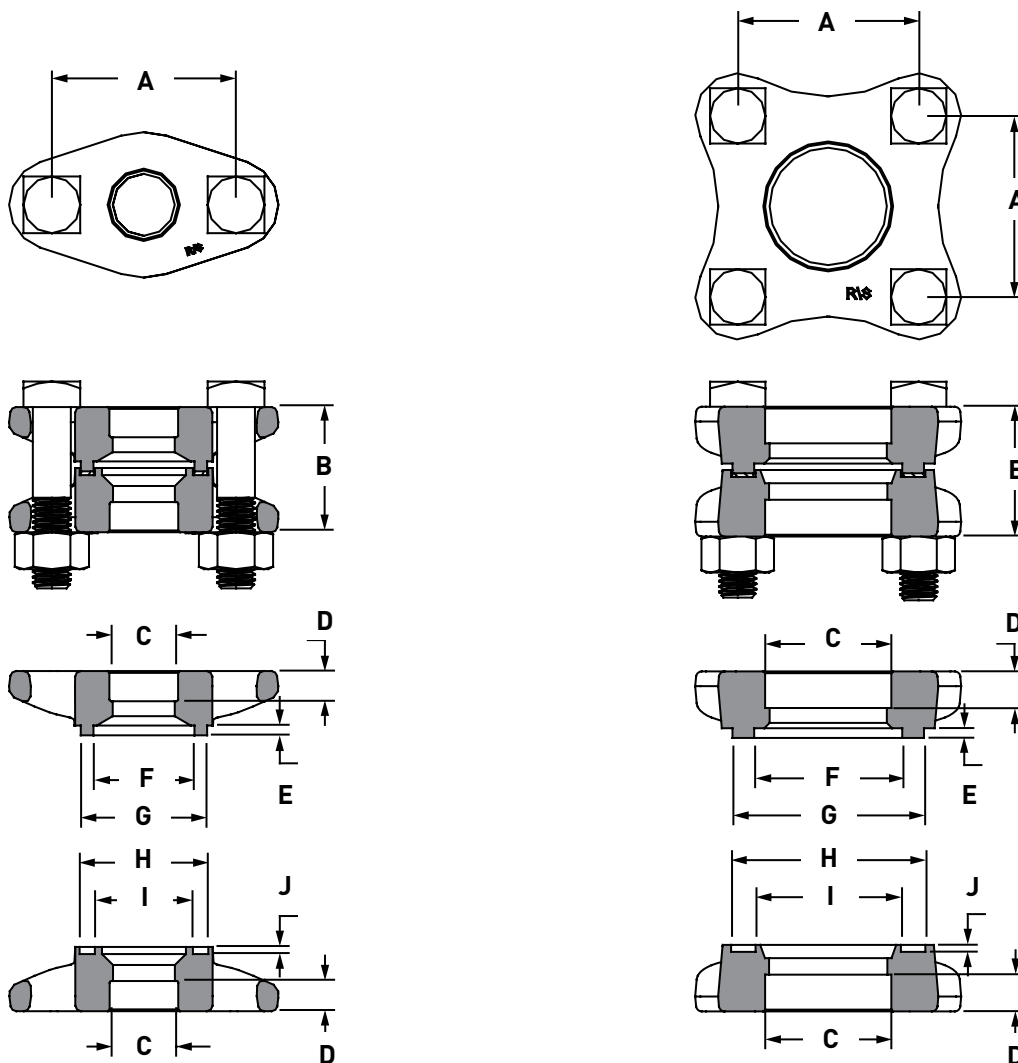

Dimensional Diagram: Outside Diameter Sweat (ODS) Flanges

Port Size		Connection (ODS)	Bolt Pattern	A	B	C	D	Male			Female		
mm	inch							E	F	G	H	I	J
13	1/2	1/2"	2	2.00"	1.50"	0.505"	0.380"	0.13"	1.00"	1.24"	1.26"	0.99"	0.12"
		5/8"				0.630"							
25	1	7/8"	2	3.05"	2.08"	0.880"	0.500"	0.16"	1.66"	2.09"	2.13"	1.62"	0.12"
		1 1/8"				1.130"							
		1 3/8"				1.380"							
32	1 1/4	1 5/8"	4	2.38"	2.08"	1.631"	0.620"	0.16"	1.85"	2.27"	2.32"	1.80"	0.12"
50	2	2 1/8"	4	3.06"	2.20"	2.137"	0.620"	0.16"	2.51"	3.24"	3.29"	2.46"	0.12"
		2 5/8"				2.631"							
65	2 1/2	2 5/8"	4	4.07"	2.61"	2.637"	0.620"	0.16"	3.00"	3.74"	3.79"	2.96"	0.12"
		3 1/8"				3.129"							
75	3	3 1/8"	4	4.07"	2.61"	3.129"	0.620"	0.16"	3.63"	4.37"	4.41"	3.59"	0.12"
		3 5/8"				3.629"							
100	4	4 1/8"	4	5.00"	2.89"	4.129"	0.875"	0.16"	4.76"	5.49"	5.54"	4.71"	0.12"

Appendix B

Industrial Valve Flanges - Weld Neck (WN)

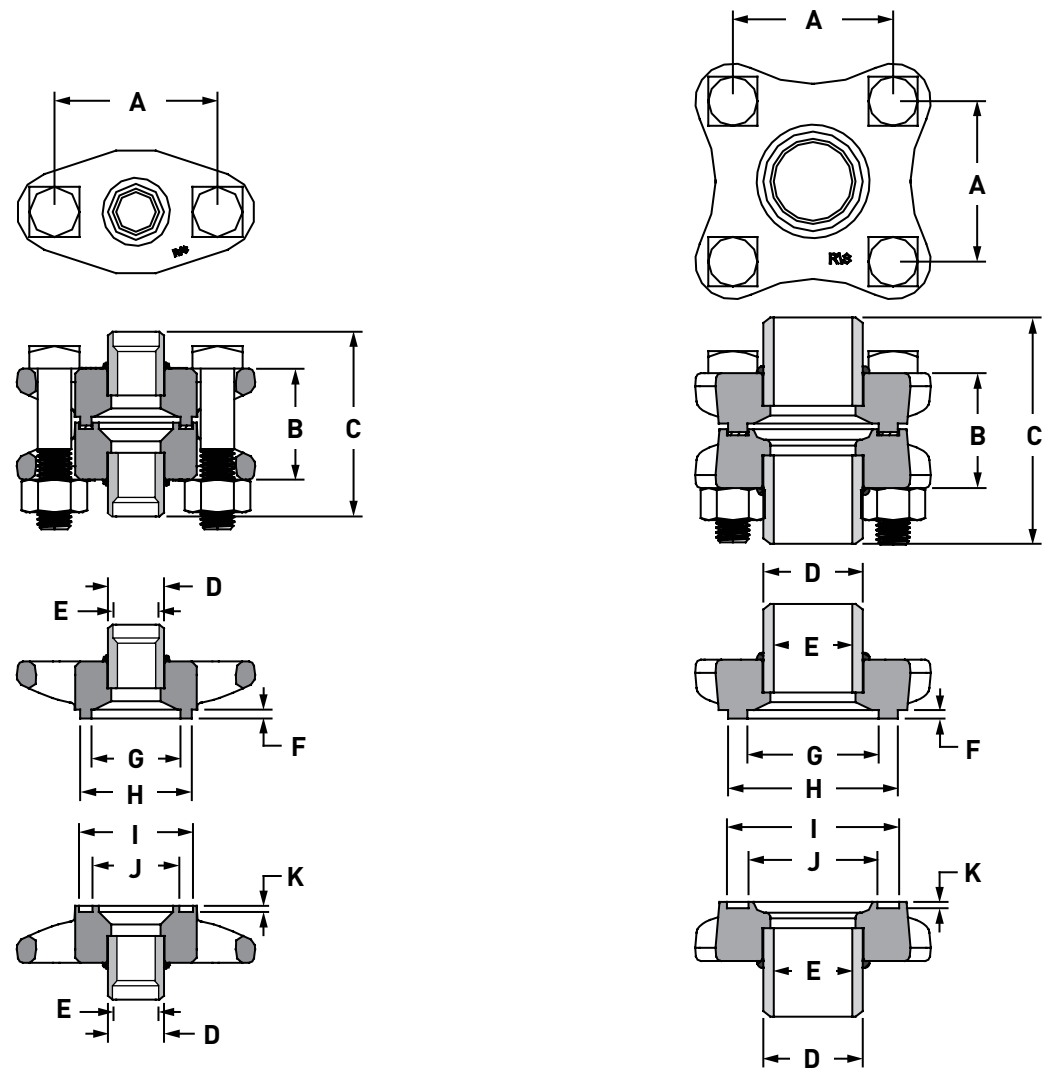

Dimensional Diagram: Weld Neck (WN) Flanges

Port Size		Connection (IPS)	Bolt Pattern	A	B	C	D	E	Male			Female		
mm	inch								F	G	H	I	J	K
13	1/2	1/4"	2	2.00"	1.50"	2.27"	0.540"	0.302"	0.13"	1.00"	1.24"	1.26"	0.99"	0.12"
		3/8"					0.675"	0.423"						
		1/2"					0.840"	0.546"						
		3/4"					1.050"	0.742"						
25	1	3/4"	2	3.05"	2.08"	3.46"	1.050"	0.742"	0.16"	1.66"	2.09"	2.13"	1.62"	0.12"
		1"				3.83"	1.315"	0.957"						
		1 1/4"				1.660"	1.278"							
32	1 1/4	1 1/4"	4	2.38"	2.08"	4.83"	1.660"	1.278"	0.16"	1.85"	2.27"	2.32"	1.80"	0.12"
		1 1/2"				4.33"	1.900"	1.500"						
50	2	1 1/2"	4	3.06"	2.20"	4.45"	1.900"	1.500"	0.16"	2.51"	3.24"	3.29"	2.46"	0.12"
		2"				4.95"	2.375"	2.067"						
65	2 1/2	2 1/2"	4	4.07"	2.61"	5.36"	2.875"	2.469"	0.16"	3.00"	3.74"	3.79"	2.96"	0.12"
		3"				6.11"	3.500"	3.068"						
75	3	3"	4	4.07"	2.61"	6.11"	3.500"	3.068"	0.16"	3.63"	4.37"	4.41"	3.59"	0.12"
100	4	4"	4	5.00"	2.89"	7.64"	4.500"	4.026"	0.16"	4.76"	5.49"	5.54"	4.71"	0.12"

Appendix B

Industrial Valve Flanges - 5" and 6"

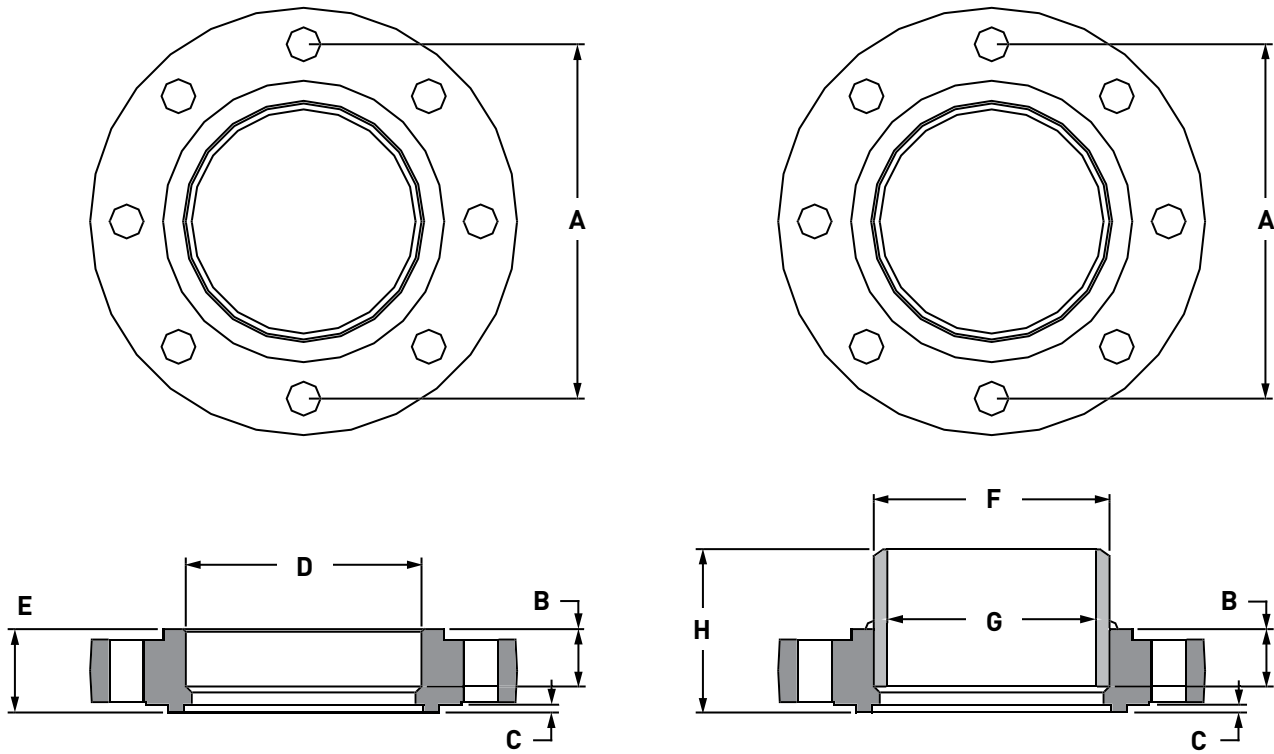

Dimensional Diagram: ANSI Flanges

Appendix B

Port Size		Connection (IPS)	Bolt Pattern	A	B	C	SW Flanges		WN Flanges		
mm	inch						D	E	F	G	H
125	5	5"	8	8.5"	1.38"	0.19"	5.66"	2.00"	5.56"	5.05"	3.75"
150	6	6"	8	9.5"	1.50"	0.16"	6.07"	2.13"	6.65"	6.00"	3.91"

Industrial Valve Flanges - Metric (DIN) Weld Neck

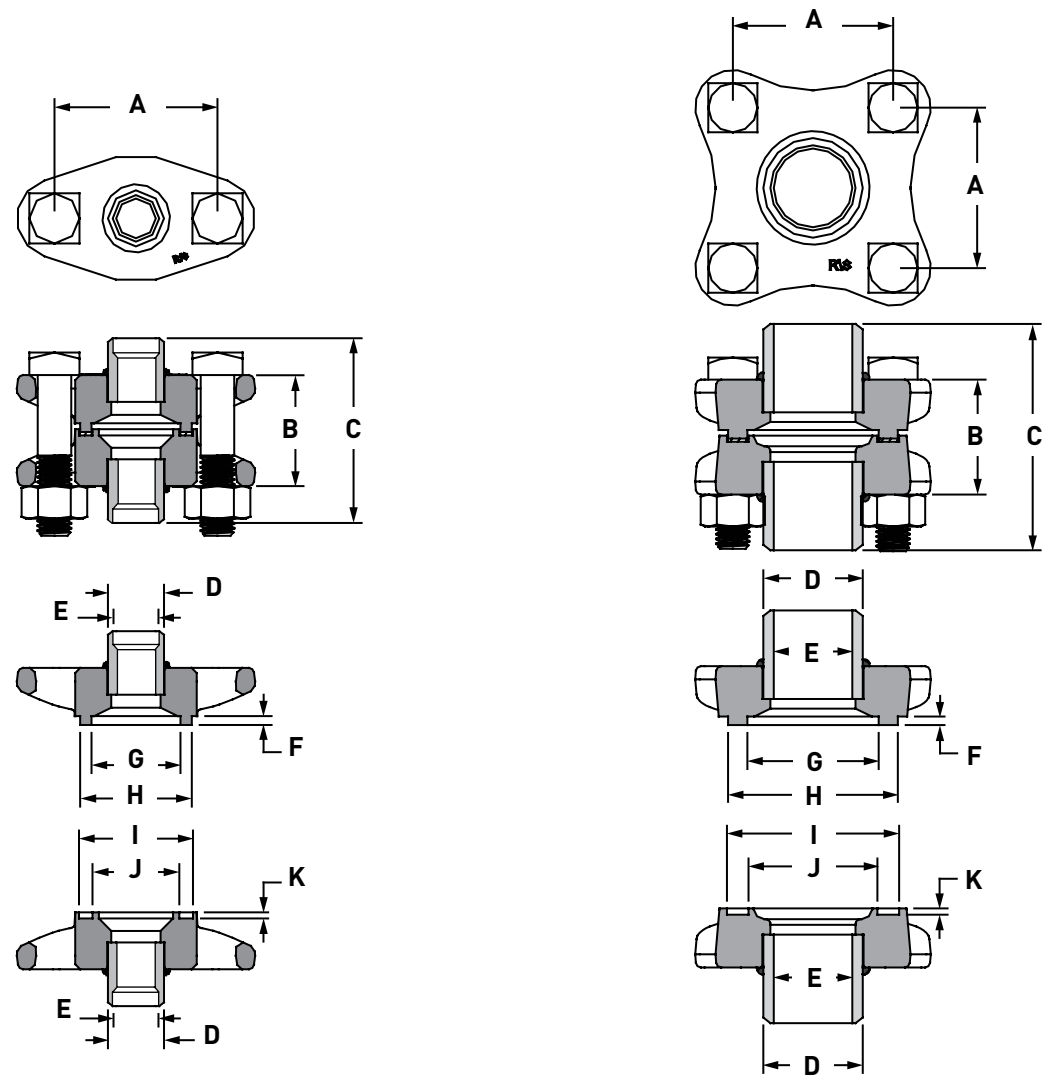

Dimensional Diagram: Metric (DIN) Weld Neck Flanges

Port Size		Connection (IPS)	Bolt Pattern	A	B	C	D	E	Male			Female		
mm	inch								F	G	H	I	J	K
13	1/2	13mm	2	2.00"	1.50"	2.27"	0.840"	0.681"	0.13"	1.00"	1.24"	1.26"	0.99"	0.12"
		20mm					1.060"	0.878"						
25	1	20mm	2	3.05"	2.08"	3.58"	1.050"	0.878"	0.16"	1.66"	2.09"	2.13"	1.62"	0.12"
		25mm				3.83"	1.327"	1.122"						
		32mm				1.660"	1.465"							
32	1 1/4	32mm	4	2.38"	2.08"	3.96"	1.660"	1.465"	0.16"	1.85"	2.27"	2.32"	1.80"	0.12"
		38mm				4.33"	1.900"	1.697"						
50	2	38mm	4	3.06"	2.20"	4.45"	1.900"	1.697"	0.16"	2.51"	3.24"	3.29"	2.46"	0.12"
		50mm				4.70"	2.374"	2.146"						
65	2 1/2	65mm	4	4.07"	2.61"	5.36"	3.000"	2.760"	0.16"	3.00"	3.74"	3.79"	2.96"	0.12"
75	3	75mm	4	4.07"	2.61"	6.11"	3.500"	3.248"	0.16"	3.63"	4.37"	4.41"	3.59"	0.12"
100	4	100mm	4	5.00"	2.89"	7.64"	4.500"	4.217"	0.16"	4.76"	5.49"	5.54"	4.71"	0.12"

Appendix B

Safety Relief Valves - H Series

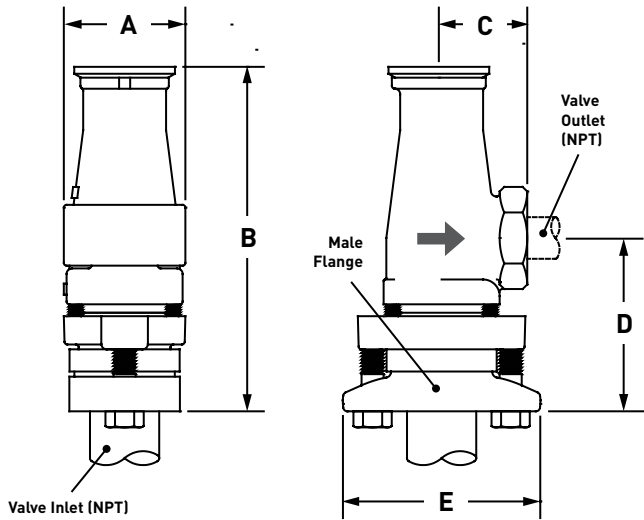

Dimension	H2		H3		H4		H5	
	mm	inch	mm	inch	mm	inch	mm	inch
Inlet	20	¾	25	1.0	32	1¼	32	1¼
Outlet	25	1.0	32	1¼	40	1½	50	2.0
A	70	2.8	92	3.6	108	4.3	152	6.0
B	193	7.6	229	9.0	267	10.5	296	11.7
C	49	1.9	62	2.4	75	2.9	81	3.2
D	96	3.8	120	4.7	137	5.4	151	5.9
E	102	4.0	102	4.0	122	4.8	122	4.8

Dimensional Diagram: H Series Safety Relief Valve (Single)

Stem Position	Port 1	Port 2
In	Open	Closed
Out	Closed	Open
Mid	Open	Open

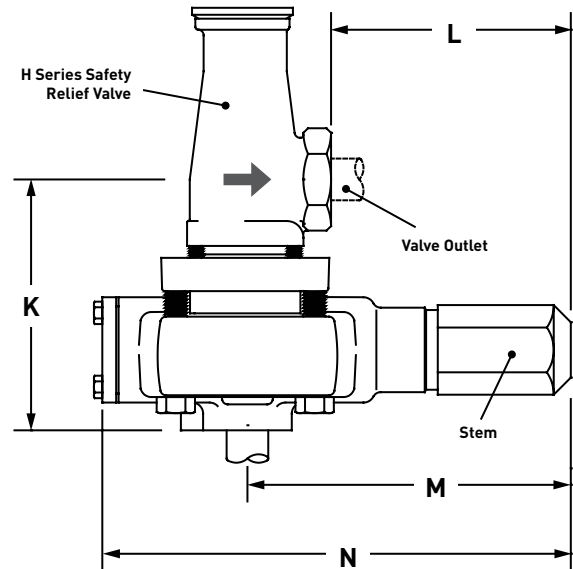
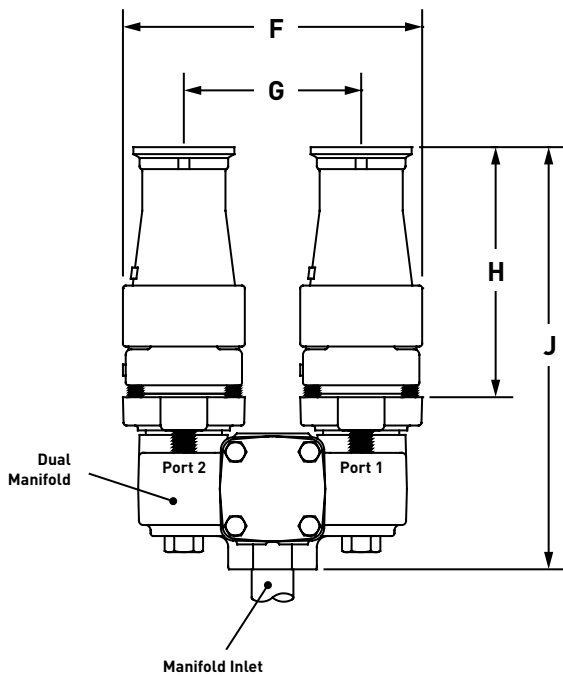

Dimensional Diagram: H Series Safety Relief Valve (Dual Valve with Manifold)

Dimension	H2 / M2		H3 / M3		H4 / M4		H5 / M4	
	mm	inch	mm	inch	mm	inch	mm	inch
Inlet	20	¾	25	1.0	32	1¼	32	1¼
F	171	6.8	219	8.6	273	10.8	318	12.5
G	102	4.0	127	5.0	165	6.5	165	6.5
H	166	6.5	202	8.0	237	9.3	266	10.5
J	251	9.9	295	11.6	340	13.4	371	14.6

Dimension	H2 / M2		H3 / M3		H4 / M4		H5 / M4	
	mm	inch	mm	inch	mm	inch	mm	inch
K	152	6.0	187	7.4	211	8.3	224	8.8
L	136	5.4	127	5.0	117	4.6	111	4.4
M	187	7.4	188	7.4	192	7.6	192	7.6
N	273	10.8	282	11.1	298	11.8	298	11.8

Safety Relief Valve Flanges - H Series

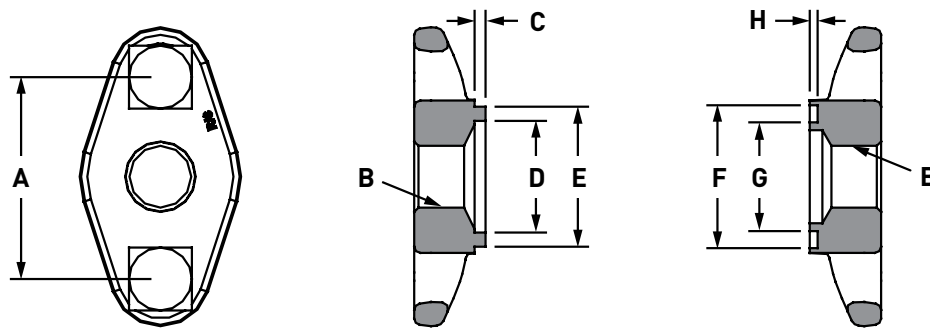

Dimensional Diagram: H Series Safety Relief Valve Threaded (FPT) Flanges

Port Size		Connection (IPS)	Bolt Pattern	A	B	Male			Female		
mm	inch					C	D	E	F	G	H
13	1/2	3/4"	2	2.63"	3/4"-14 FPT	0.16"	1.28"	1.72"	1.75"	1.25"	0.13"
		1"			1"-11 1/2 FPT						
20	3/4	1"	2	2.75"	1 1/4"-11 1/2 FPT	0.16"	1.34"	1.78"	1.81"	1.31"	0.13"
32	1 1/4	1 1/4"	2	3.31"	1 1/4"-11 1/2 FPT	0.16"	1.85"	2.30"	2.34"	1.79"	0.13"
		1 1/2"			1 1/2"-11 1/2 FPT						

Safety Relief Valves - SR/SRH/SRL Series

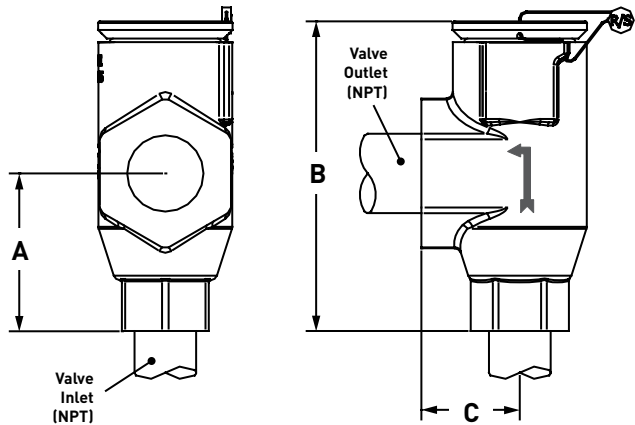

Dimensional Diagram: SR/SRL Series Safety Relief Valve (Single)

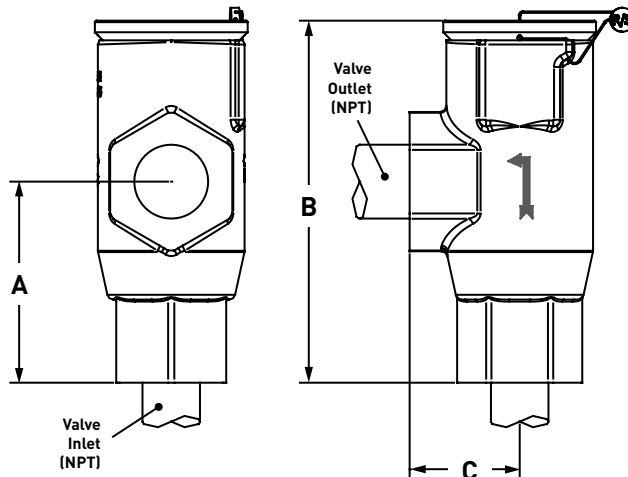

Dimensional Diagram: SRH Series Safety Relief Valve (Single)

Dimension	SR1		SR2		SR3		SR4	
	mm	inch	mm	inch	mm	inch	mm	inch
Inlet	13	1/2	13	1/2	20	3/4	20	3/4
Outlet	20	3/4	25	1	32	1 1/4	40	1 1/2
A	70	2.75	70	2.75	76	3.00	76	3.00
B	128	5.05	128	5.05	150	5.92	150	5.92
C	40	1.56	40	1.56	48	1.875	48	1.875

Dim.	SRH1		SRH2		SRH3		SRH4		SRH5	
	mm	inch	mm	inch	mm	inch	mm	inch	mm	inch
Inlet	13	1/2	13	1/2	20	3/4	25	1	32	1 1/4
Outlet	20	3/4	25	1	25	1	32	1 1/4	40	1 1/2
A	70	2.75	70	2.75	70	2.75	104	4.11	104	4.11
B	128	5.05	128	5.05	128	5.05	188	7.40	188	7.40
C	40	1.56	40	1.56	40	1.56	57	2.25	57	2.25

Dimension	SR1L		SR2L	
	mm	inch	mm	inch
Inlet	13	1/2	13	1/2
Outlet	20	3/4	25	1
A	70	2.75	70	2.75
B	128	5.05	128	5.05
C	40	1.56	40	1.56

Appendix B

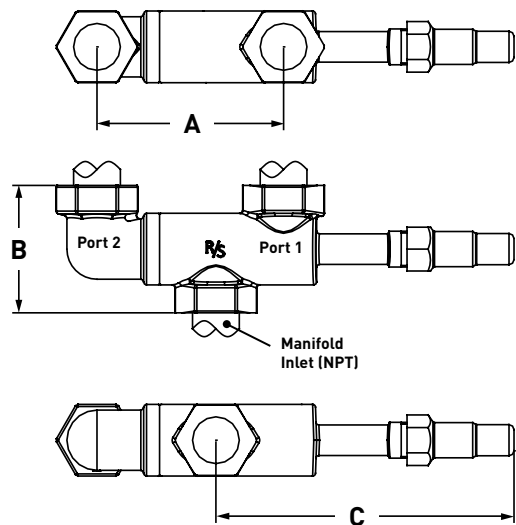

Stem Position	Port 1	Port 2
In	Open	Closed
Out	Closed	Open
Mid	Open	Open

Dimension	M1 (1/2")		M1 (3/4")		M1 (1")		M1 (1 1/4")	
	mm	inch	mm	inch	mm	inch	mm	inch
Inlet	13	1/2	20	3/4	25	1	32	1 1/4
A	92	3.6	92	3.6	149	5.9	149	5.9
B	84	3.3	84	3.3	101	4.4	101	4.0
C	159	6.3	159	6.3	236	9.3	236	9.3

Dimensional Diagram: M1 Dual SR/SRH Safety Relief Valve Manifold

Hand Shut-Off and Hand Expansion Valves

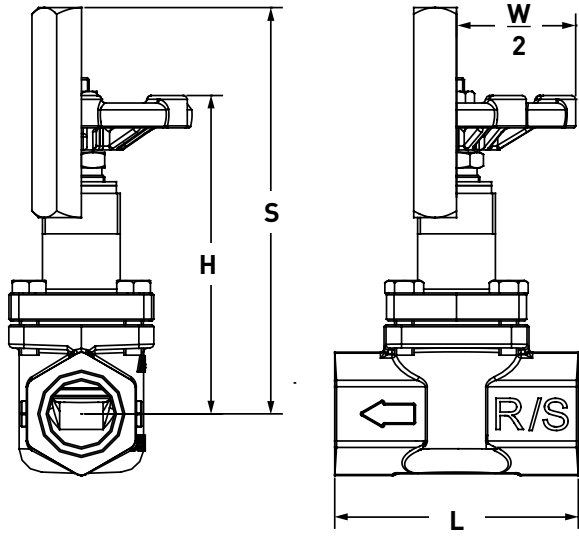

Dimensional Diagram: FPT Globe "T" Body

Port Size		L		H		S		W	
mm	inch	mm	inch	mm	inch	mm	inch	mm	inch
6	¼	94	3.7	114	4.5	143	5.63	64	2.5
10	⅜	94	3.7	114	4.5	143	5.63	64	2.5
13	½	94	3.7	114	4.5	143	5.63	64	2.5
20	¾	100	4.0	152	6.0	191	7.5	108	4.3
25	1	100	4.0	152	6.0	191	7.5	108	4.3

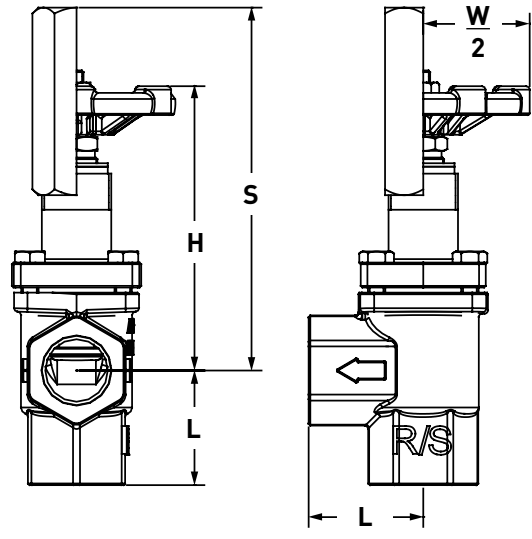

Dimensional Diagram: FPT Angle Body

Port Size		L		H		S		W	
mm	inch	mm	inch	mm	inch	mm	inch	mm	inch
6	¼	45	1.8	114	4.5	143	5.6	64	2.5
10	⅜	45	1.8	114	4.5	143	5.6	64	2.5
13	½	45	1.8	114	4.5	143	5.6	64	2.5
20	¾	52	2.1	152	6.0	191	7.5	108	4.3
25	1	52	2.1	152	6.0	191	7.5	108	4.3

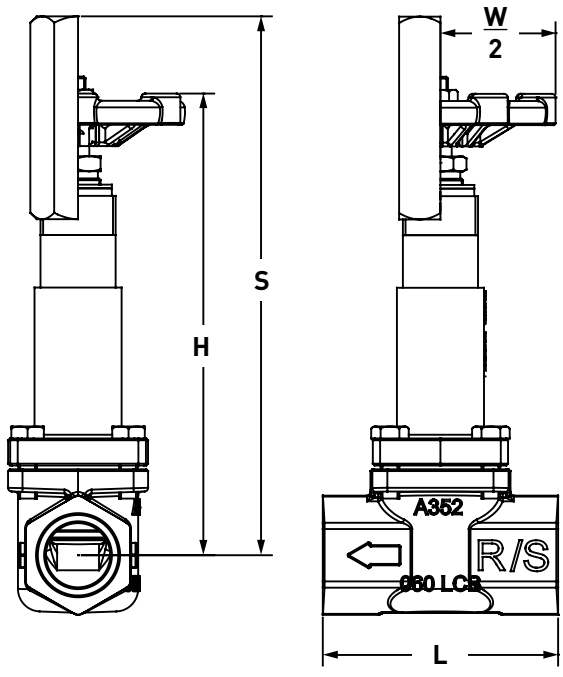

Dimensional Diagram: FPT Extended Bonnet Globe "T" Body

Port Size		L		H		S		W	
mm	inch	mm	inch	mm	inch	mm	inch	mm	inch
13	½	94	3.7	184	7.3	207	8.1	64	2.5
20	¾	100	4.0	216	8.5	254	10.0	108	4.2
25	1	100	4.0	216	8.5	254	10.0	108	4.2

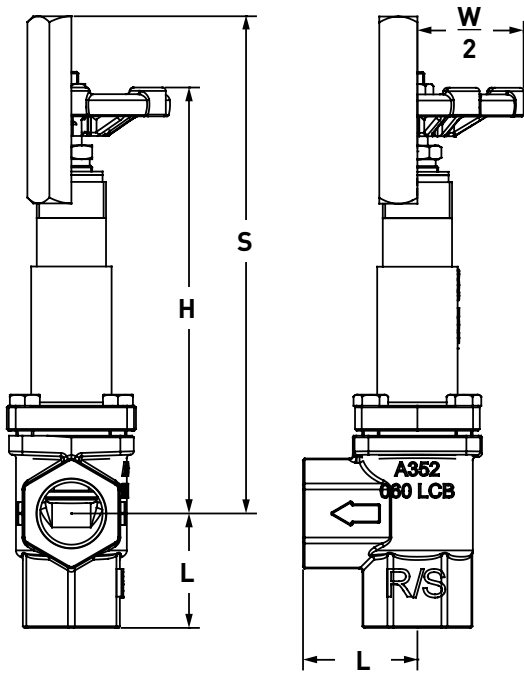

Dimensional Diagram: FPT Extended Bonnet Angle Body

Port Size		L		H		S		W	
mm	inch	mm	inch	mm	inch	mm	inch	mm	inch
13	½	45	1.8	184	7.3	207	8.1	64	2.5
20	¾	52	2.1	216	8.5	254	10.0	108	4.2
25	1	52	2.1	216	8.5	254	10.0	108	4.2

Appendix B

Hand Shut-Off and Hand Expansion Valves

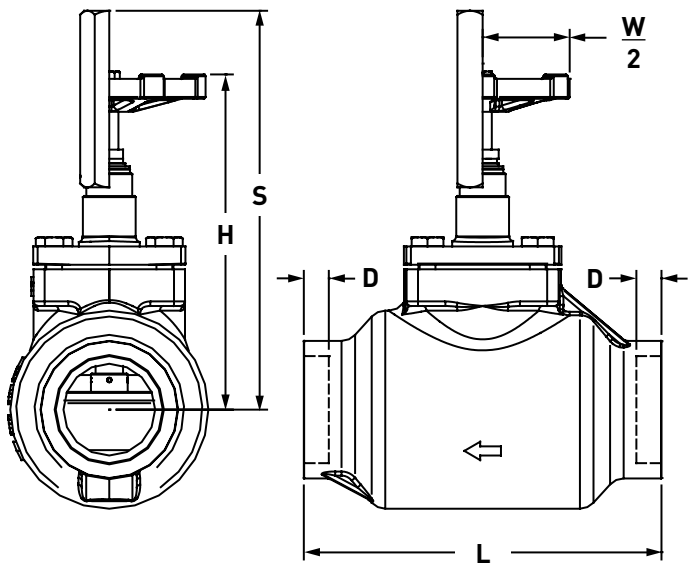

Dimensional Diagram: SW Globe "T" Body

Port Size		L		D		H		S		W	
mm	in	mm	in	mm	in	mm	in	mm	in	mm	in
6	¼	94	3.7	10	0.4	114	4.5	143	5.6	64	2.5
10	¾	94	3.7	10	0.4	114	4.5	143	5.6	64	2.5
13	½	94	3.7	10	0.4	114	4.5	143	5.6	64	2.5
20	¾	100	4.0	13	0.5	152	6.0	191	7.5	108	4.3
25	1	100	4.0	13	0.5	152	6.0	191	7.5	108	4.3
32	1¼	175	6.9	14	0.6	165	6.5	206	8.1	137	5.4
40	1½	208	8.2	14	0.6	168	6.2	210	8.3	137	5.4
50	2	208	8.2	17	0.7	172	6.8	219	8.6	137	5.4
65	2½	241	9.5	17	0.7	210	8.3	232	9.1	137	5.4

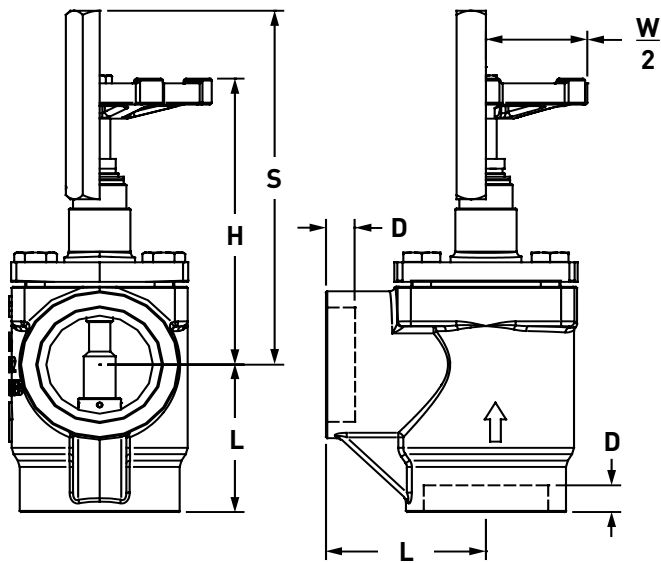

Dimensional Diagram: SW Angle Body

Port Size		L		D		H		S		W	
mm	in	mm	in	mm	in	mm	in	mm	in	mm	in
6	¼	45	1.8	10	0.4	114	4.5	143	5.6	64	2.5
10	¾	45	1.8	10	0.4	114	4.5	143	5.6	64	2.5
13	½	45	1.8	10	0.4	114	4.5	143	5.6	64	2.5
20	¾	52	2.1	13	0.5	152	6.0	191	7.5	108	4.3
25	1	52	2.1	13	0.5	152	6.0	191	7.5	108	4.3
32	1¼	68	2.7	14	0.6	165	6.5	206	8.1	137	5.4
40	1½	66	2.6	14	0.6	168	6.2	210	8.3	137	5.4
50	2	78	3.1	17	0.7	172	6.8	219	8.6	137	5.4
65	2½	92	3.6	17	0.7	210	8.3	232	9.1	137	5.4
75	3	93	3.7	17	0.7	257	10.1	295	11.6	159	6.3
100	4	112	4.4	21	0.8	273	10.8	308	12.1	159	6.3

Appendix B

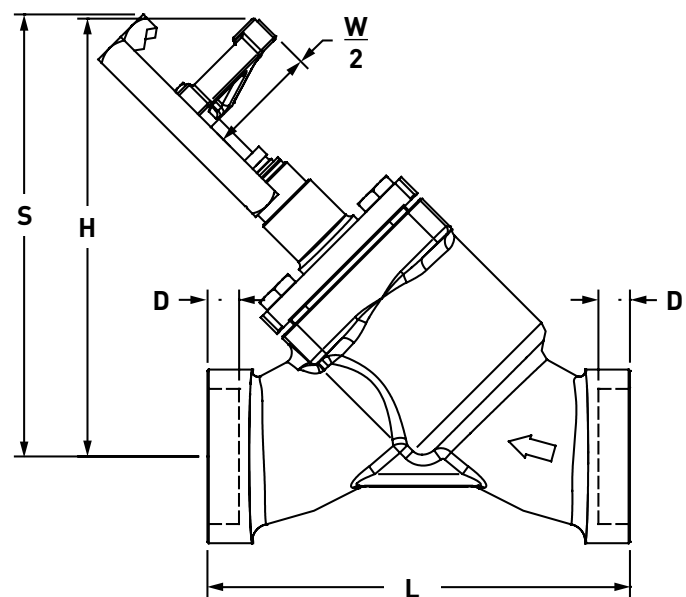

Dimensional Diagram: SW Globe "Y" Body

Port Size		L		D		H		S		W	
mm	in	mm	in	mm	in	mm	in	mm	in	mm	in
32	1¼	159	6.3	14	0.6	165	6.5	197	7.8	137	5.4
40	1½	159	6.3	14	0.6	165	6.5	197	7.8	137	5.4
50	2	202	8.0	17	0.7	175	6.9	210	8.3	137	5.4
65	2½	229	9.0	17	0.7	216	8.5	232	9.1	137	5.4
75	3	286	11.3	17	0.7	257	10.1	286	11.3	159	6.3
100	4	340	13.4	21	0.8	279	11.0	305	12.0	159	6.3

Hand Shut-Off and Hand Expansion Valves

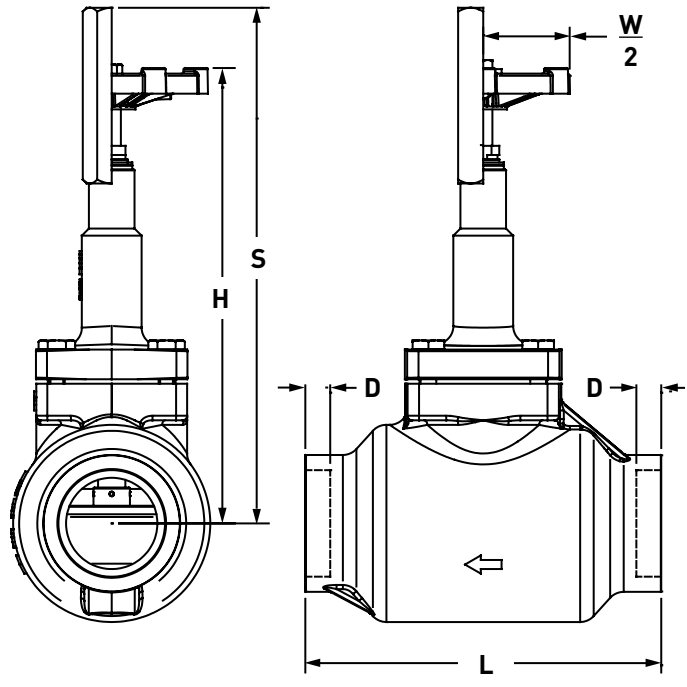

Dimensional Diagram: SW Extended Bonnet Globe "T" Body

Port Size		L		D		H		S		W	
mm	in	mm	in	mm	in	mm	in	mm	in	mm	in
13	½	94	3.7	10	0.4	143	5.6	184	7.3	64	2.5
20	¾	100	4.0	13	0.5	191	7.5	216	8.5	108	4.3
25	1	100	4.0	13	0.5	191	7.5	216	8.5	108	4.3
32	1¼	175	6.9	14	0.6	206	8.1	257	10.1	137	5.4
40	1½	208	8.2	14	0.6	210	8.3	292	11.5	137	5.4
50	2	208	8.2	17	0.7	219	8.6	292	11.5	137	5.4
65	2½	241	9.5	17	0.7	232	9.1	311	12.3	137	5.4

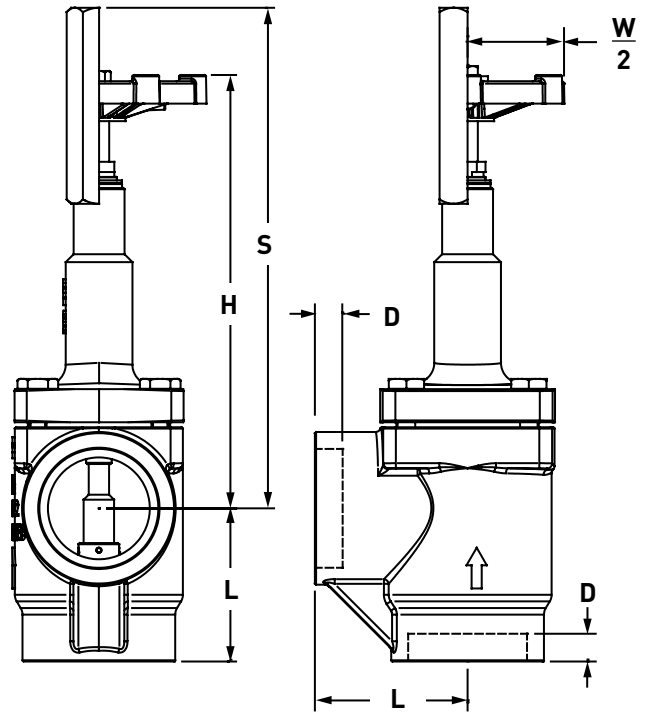

Dimensional Diagram: SW Extended Bonnet Angle Body

Port Size		L		D		H		S		W	
mm	in	mm	in	mm	in	mm	in	mm	in	mm	in
13	½	45	1.8	10	0.4	143	5.6	184	7.3	64	2.5
20	¾	52	2.1	13	0.5	191	7.5	216	8.5	108	4.3
25	1	52	2.1	13	0.5	191	7.5	216	8.5	108	4.3
32	1¼	68	2.7	14	0.6	206	8.1	229	9.0	137	5.4
40	1½	66	2.6	14	0.6	210	8.3	245	9.6	137	5.4
50	2	78	3.1	17	0.7	219	8.6	254	10.0	137	5.4
65	2½	92	3.6	17	0.7	232	9.1	267	10.5	137	5.4
75	3	93	3.7	17	0.7	295	11.6	283	11.1	159	6.3
100	4	112	4.4	21	0.8	308	12.1	327	12.9	159	6.3

Appendix B

Hand Shut-Off and Hand Expansion Valves

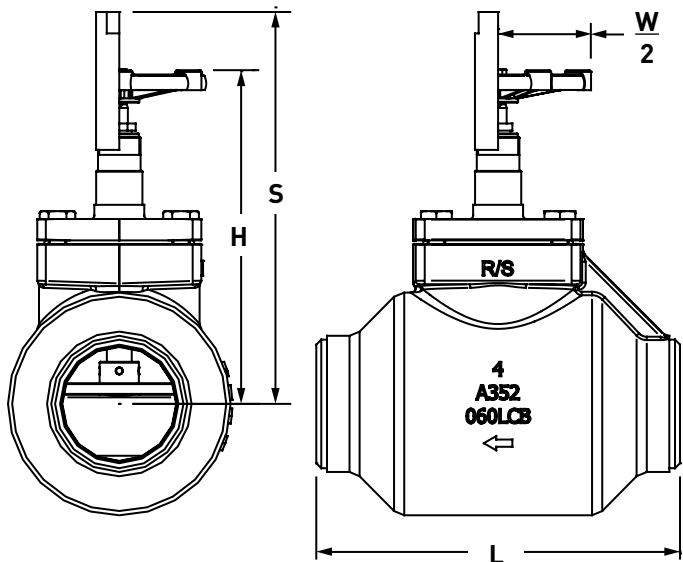

Dimensional Diagram: WN Globe "T" Body

Port Size		L		H		S		W	
mm	inch	mm	inch	mm	inch	mm	inch	mm	inch
75	3	283	11.1	308	12.1	346	13.6	159	6.3
100	4	305	12.0	391	15.4	426	16.8	159	6.3

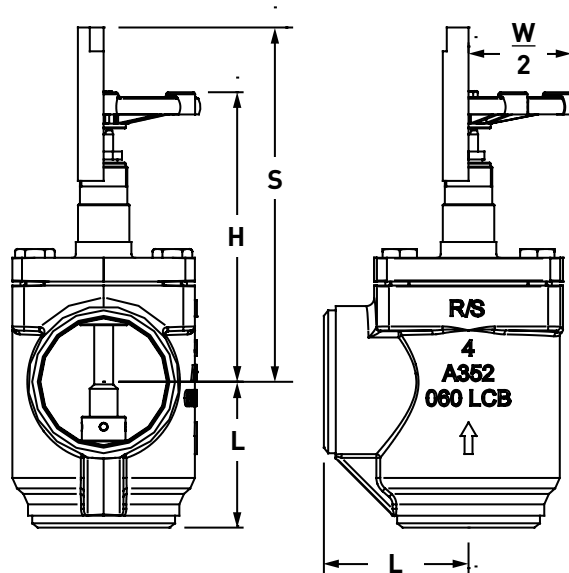

Dimensional Diagram: WN Angle Body

Port Size		L		H		S		W	
mm	inch	mm	inch	mm	inch	mm	inch	mm	inch
32	1¼	68	2.7	165	6.5	206	8.1	137	5.4
40	1½	66	2.6	168	6.2	210	8.3	137	5.4
50	2	77	3.0	171	6.8	219	8.6	137	5.4
65	2½	92	3.6	210	8.3	231	9.1	137	5.4
75	3	91	3.6	257	10.1	295	11.6	159	6.3
100	4	112	4.4	273	10.8	308	12.1	159	6.3
125	5	154	6.1	302	11.9	400	15.8	305	12.0
160	6	163	6.4	384	15.1	483	19.0	305	12.0
200	8	200	7.9	448	17.6	546	21.5	305	12.0
250	10	248	9.8	660	26.0	683	26.9	413	16.3
300	12	267	10.5	737	29.0	794	31.3	413	16.3

Appendix B

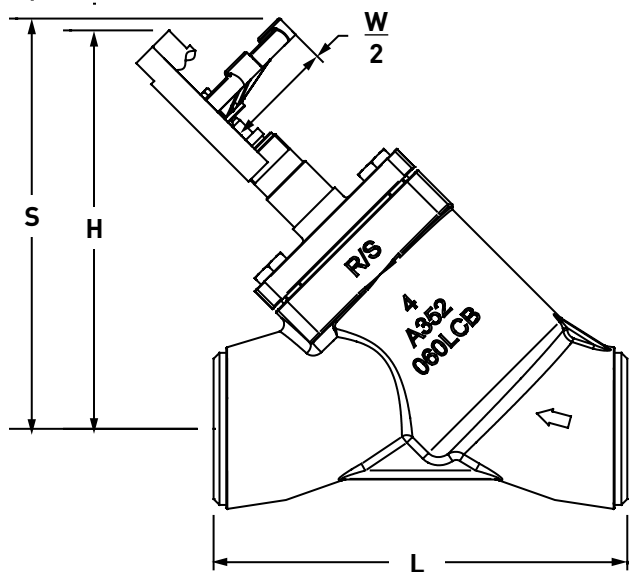

Dimensional Diagram: WN Globe "Y" Body

Port Size		L		H		S		W	
mm	in	mm	in	mm	in	mm	in	mm	in
32	1¼	178	7.0	165	6.5	197	7.8	137	5.4
40	1½	194	7.6	165	6.5	19	7.8	137	5.4
50	2	206	8.1	175	6.9	210	8.3	137	5.4
65	2½	248	9.8	216	8.5	232	9.1	137	5.4
75	3	286	11.3	257	10.1	286	11.3	159	6.3
100	4	300	11.8	279	11.0	305	12.0	159	6.3
125	5	489	19.3	378	14.9	448	17.6	305	12.0
150	6	556	21.9	457	18.0	527	20.8	305	12.0
200	8	718	28.3	546	21.5	616	24.3	305	12.0
250	10	892	35.1	730	28.8	772	30.4	413	16.3
300	12	1028	40.5	845	33.3	886	34.9	413	16.3

Hand Shut-Off and Hand Expansion Valves

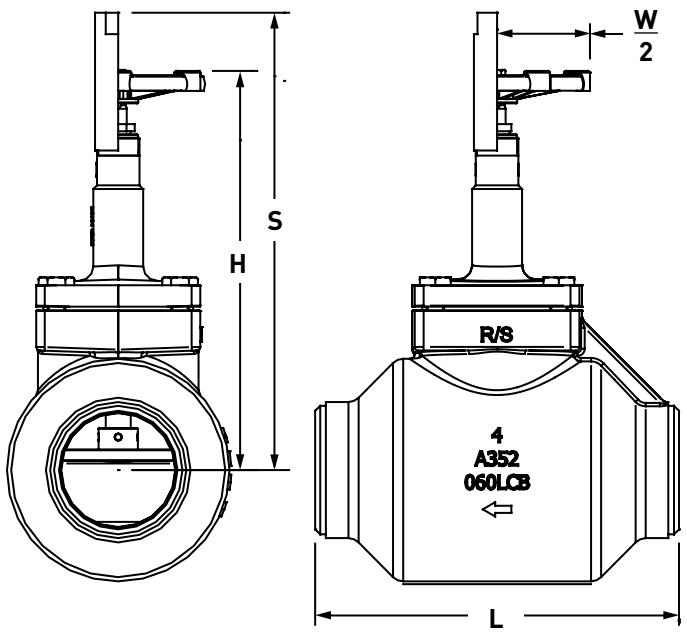

Dimensional Diagram: WN Extended Bonnet Globe "T" Body

Port Size		L		H		S		W	
mm	inch	mm	inch	mm	inch	mm	inch	mm	inch
75	3	283	11.1	337	13.3	346	13.6	159	6.3
100	4	305	12.0	387	15.3	426	16.8	159	6.3

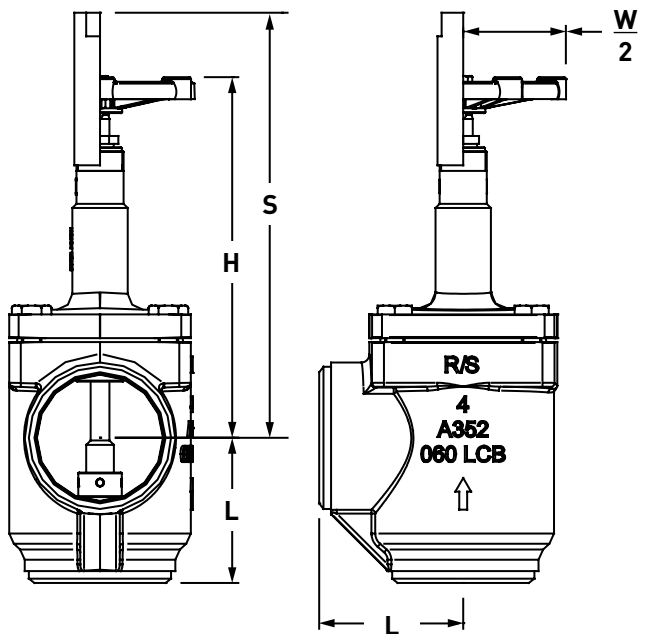

Dimensional Diagram: WN Extended Bonnet Angle Body

Port Size		L		H		S		W	
mm	inch	mm	inch	mm	inch	mm	inch	mm	inch
32	1¼	68	2.7	206	8.1	229	9.0	137	5.4
40	1½	66	2.6	210	4.3	245	9.6	137	5.4
50	2	77	3.0	219	8.6	254	10.0	137	5.4
65	2½	92	3.6	232	9.1	267	10.5	137	5.4
75	3	91	3.6	295	11.6	283	11.1	159	6.3
100	4	112	4.4	308	12.1	327	12.9	159	6.3

Liquid Level Controls

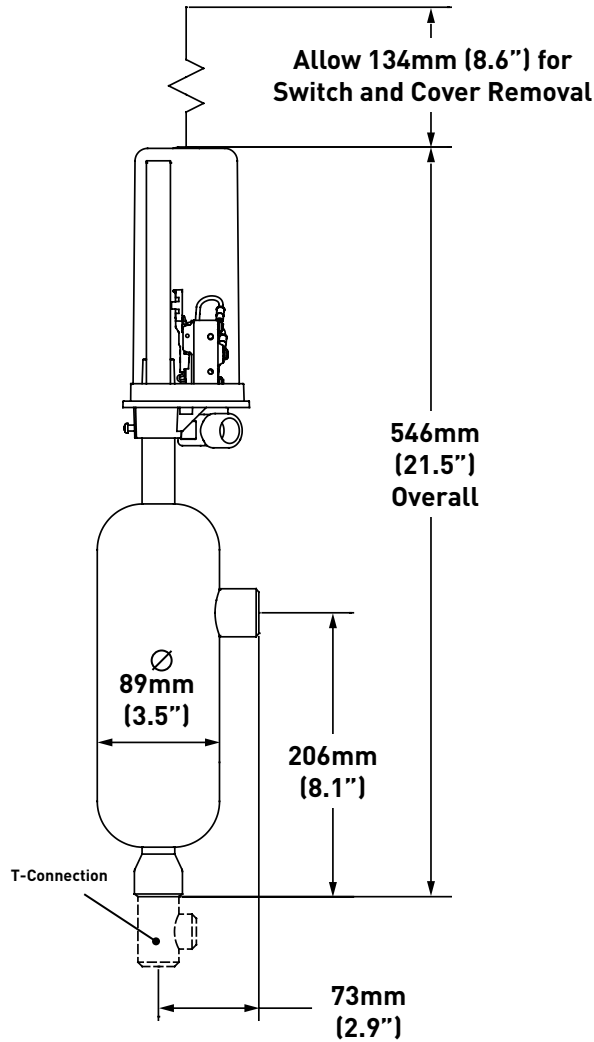

Dimensional Diagram: Refrigerant Float Switch (LLSS)

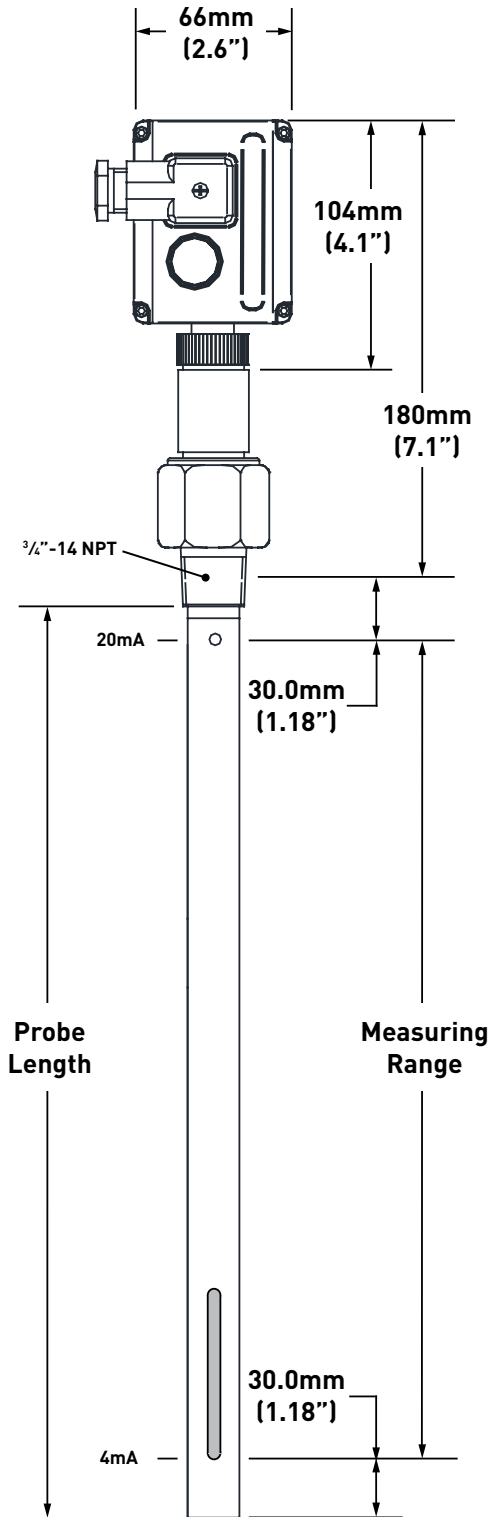

Dimensional Diagram: Liquid Level Transmitter (HBLT-A1)

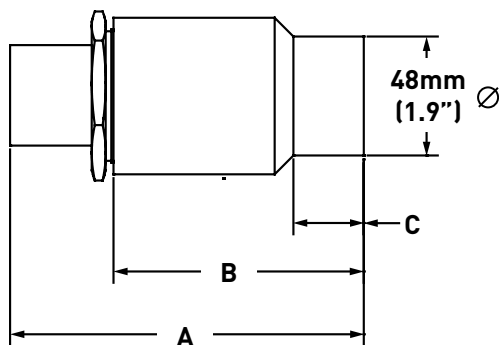

Dimensional Diagram: Liquid Level Sight Glass (SG1)

Length	A		B		C	
	mm	inch	mm	inch	mm	inch
2	103	4.1	51	2.0	29	1.1
4	144	5.7	102	4.0	29	1.1
4 x 2 ³ / ₈	144	5.7	102	4.0	60	2.4

Probe Length	mm	152	203	305	389	488	587	762
	inch	6.0	8.0	12	15	19	23	30

Probe Length	mm	889	1143	1397	1651	2159	2667	3048
	inch	35	45	55	65	85	105	120

Liquid Level Controls

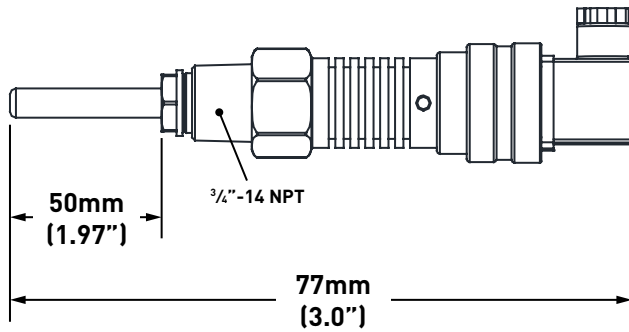

Dimensional Diagram: Liquid Switch: NH₃, HFC, Brine, Water (HBSR)

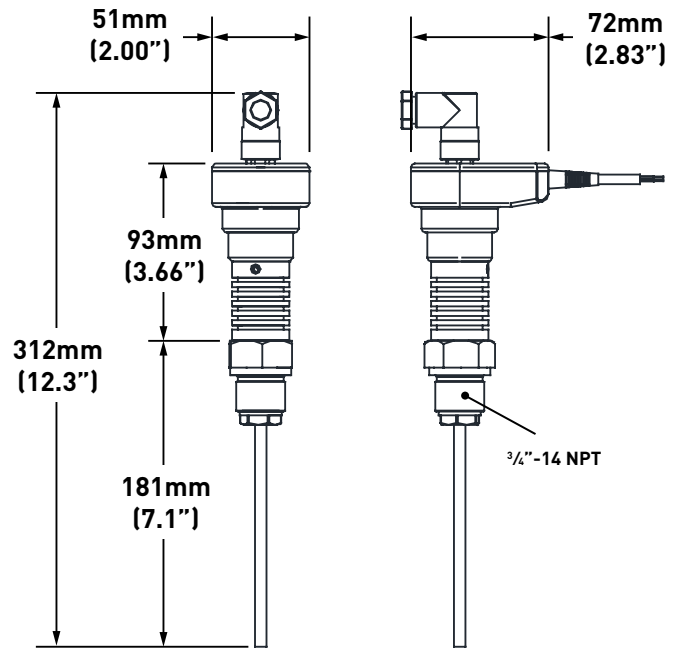

Dimensional Diagram: Liquid Level Control Sensor (HBLC)

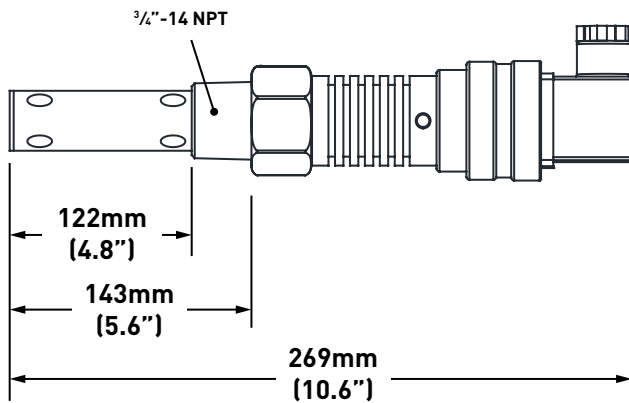

Dimensional Diagram: Liquid CO₂ Switch (HBSC2)

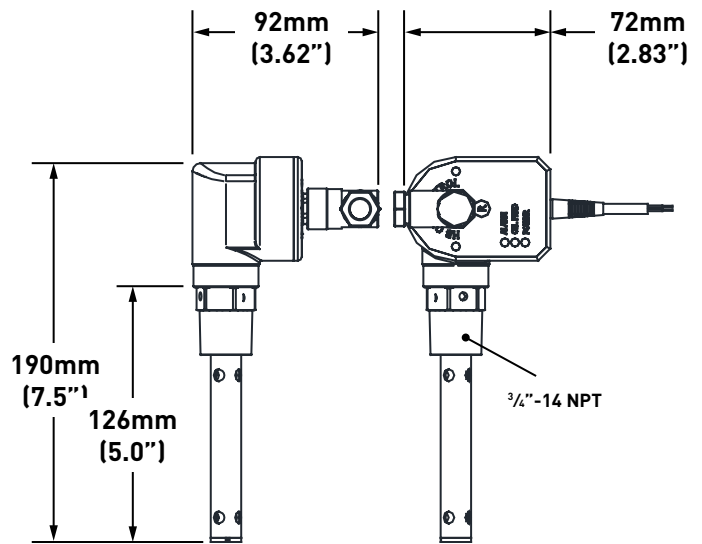

Dimensional Diagram: Oil Level Control Sensor (HBOC)

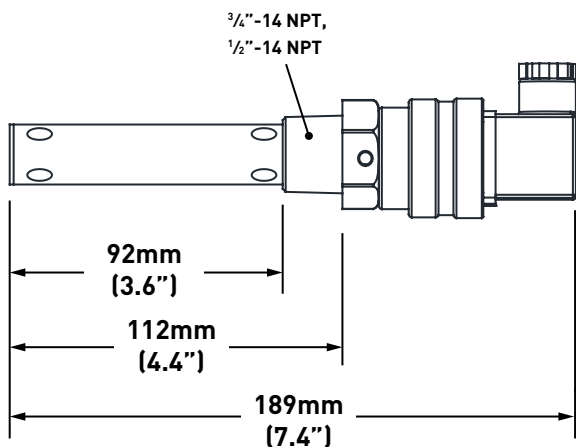

Dimensional Diagram: Oil Level Switch (HBSO1)

Rapid Purger - Model V200

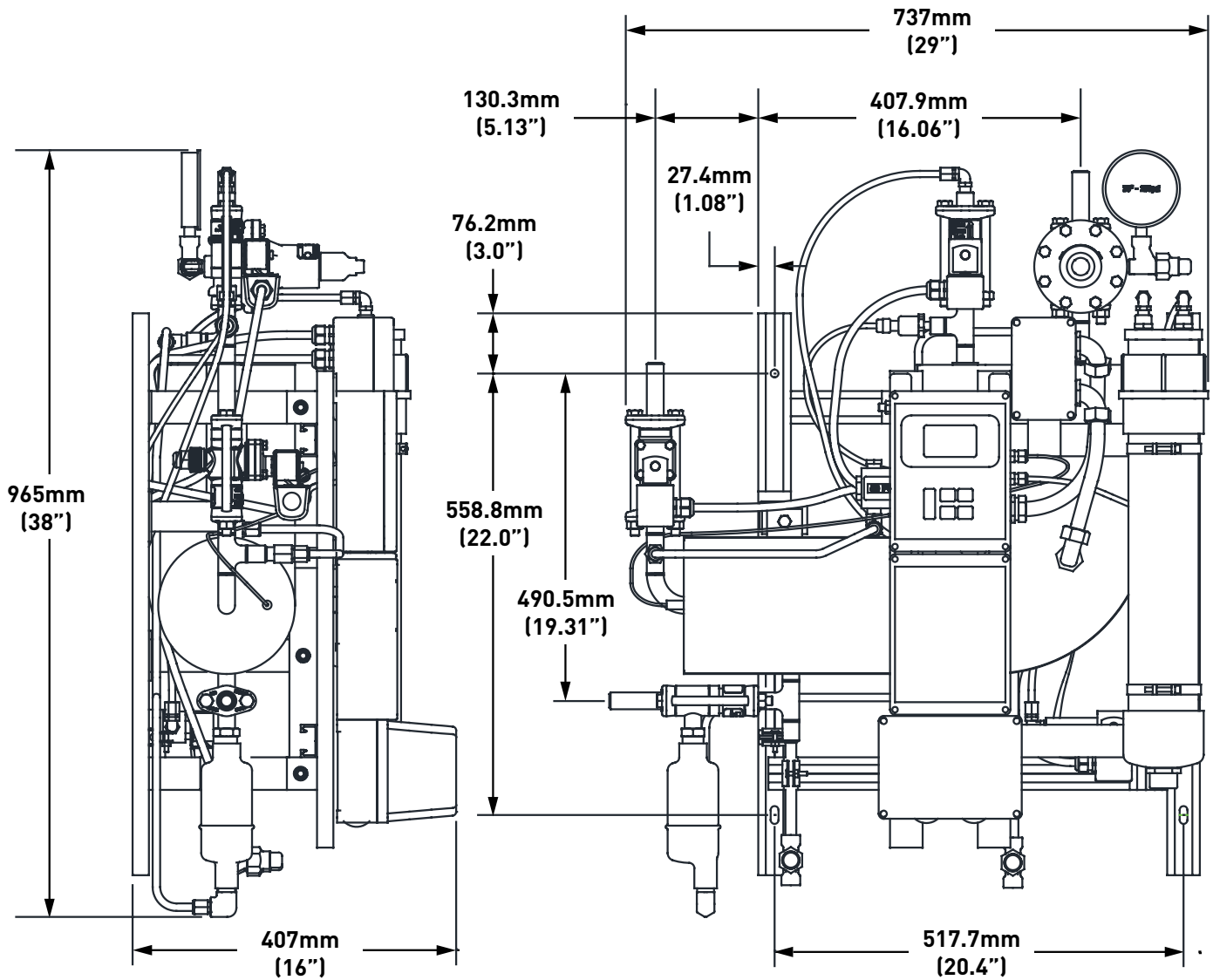

Appendix B

Modulating Refrigerant Valve - MVS

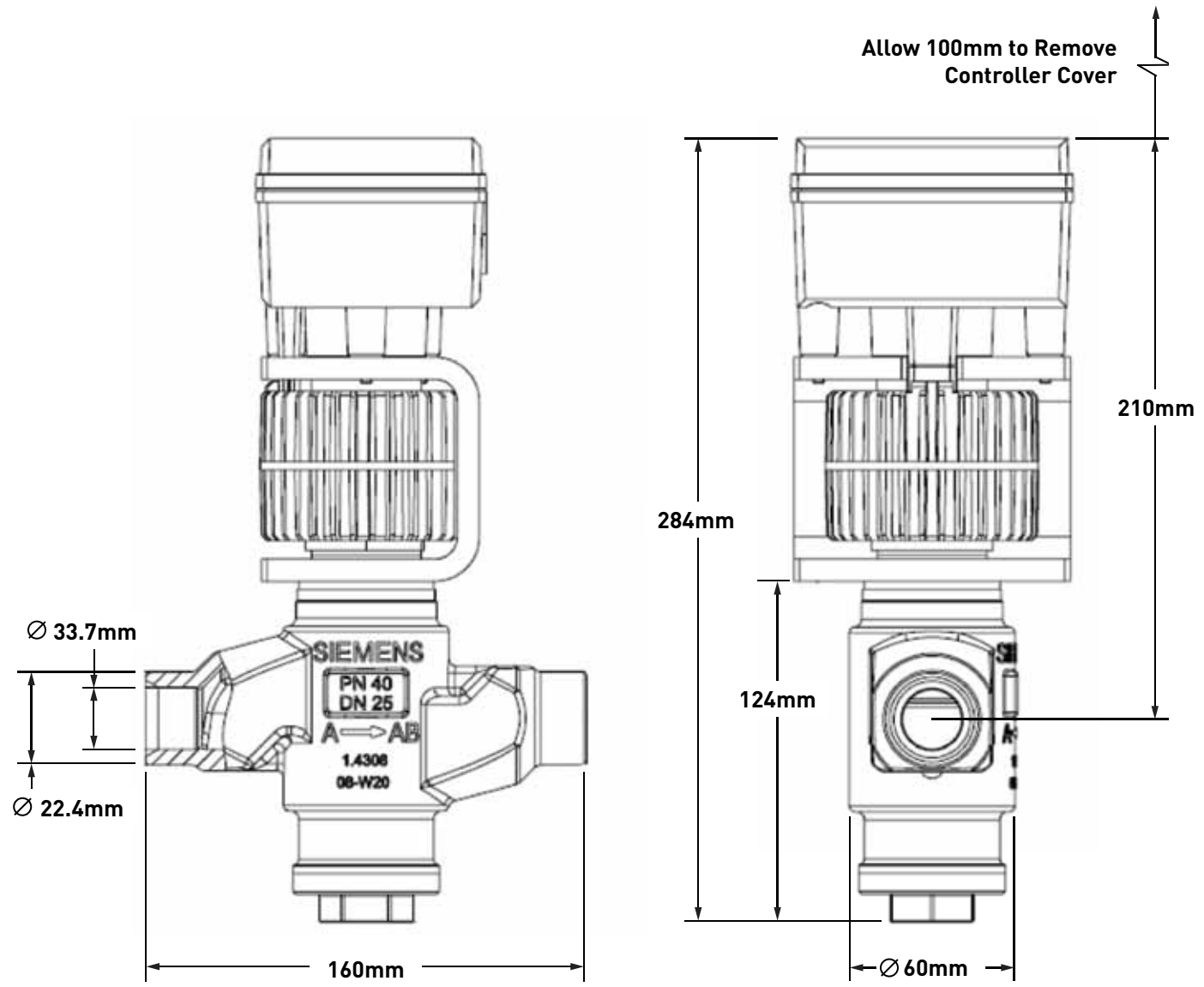

Appendix B

Thermostatic Expansion Valves

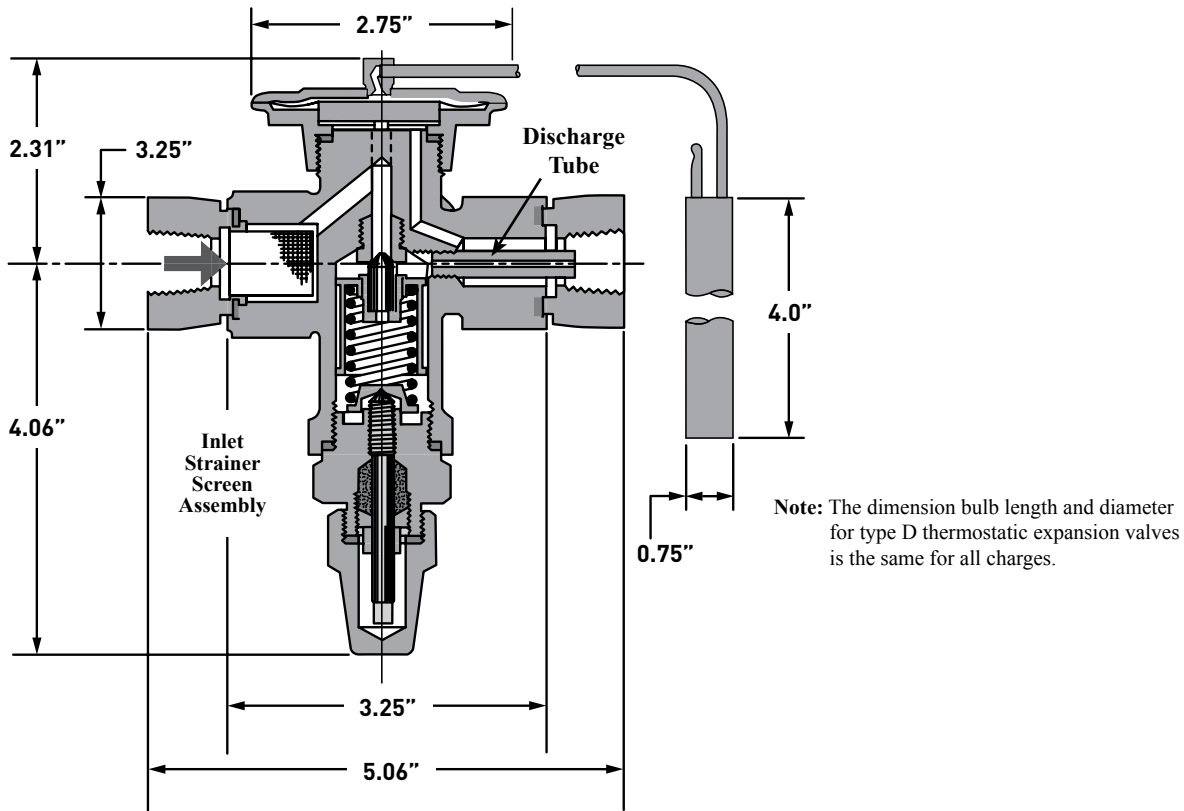

Dimensional Diagram: Type D Thermostatic Expansion Valves

Appendix B

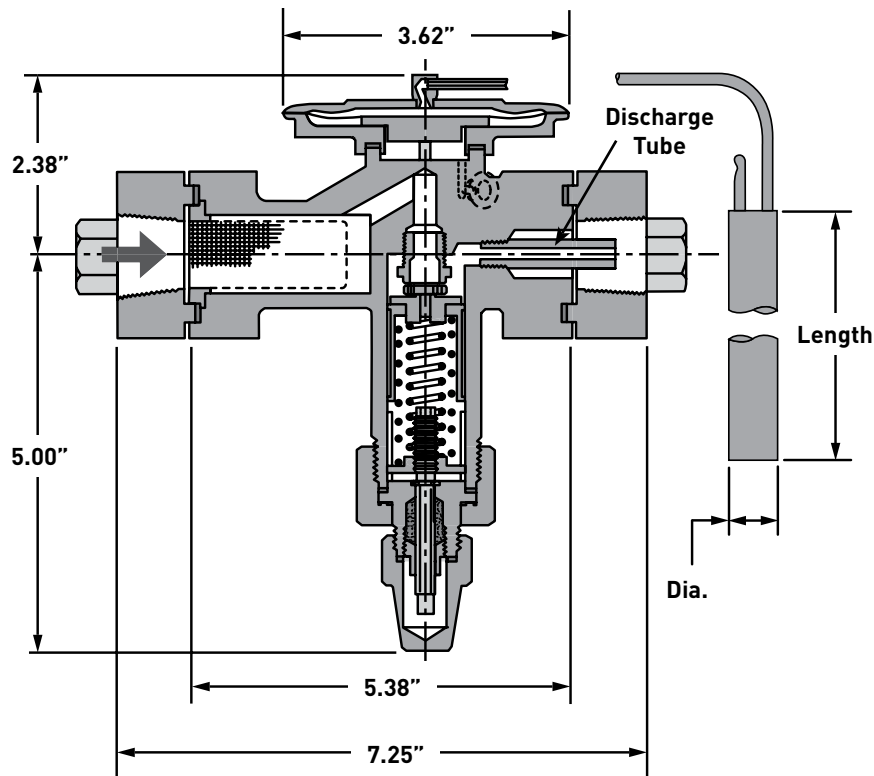

Type A Thermostatic Expansion Valves Bulb Size		
Charge	Length (in)	Diameter (in)
L	6.0	0.875
Y1182	4.0	0.75
Y830	4.0	0.75
Y832	4.0	0.75
Y1199	4.0	0.75

Dimensional Diagram: Type A Thermostatic Expansion Valves

Refrigerant Distributors

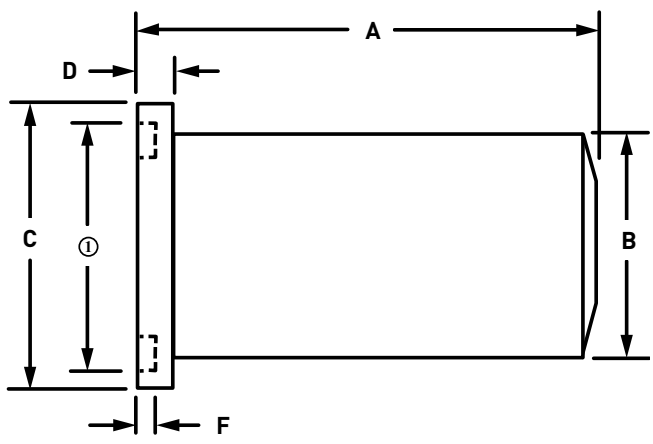

① Male Flange
1.099 OD x .776 ID

Dimensional Diagram: 1132 and 1180 Ammonia Distributors

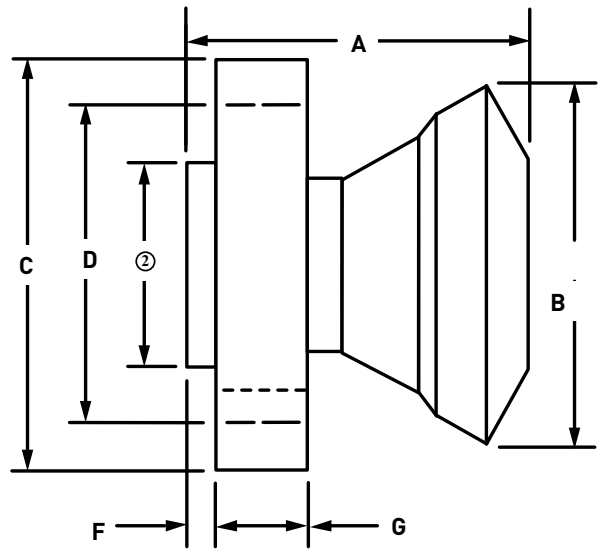

② 1130-1182 Male Flange 1.099 OD x .776 ID
1138-1185 Male Flange 1.718 OD x 1.281 ID

Dimensional Diagram: 1130, 1182, 1138 and 1185 Ammonia Distributors

No. Circuits & Tubing Sizes Available	Approximate Net Weight	Dimensions (Inches)						
		A	B	C	D	E	F	G
Type 1132 Steel	9 Oz.	2.44	1.12	1.37	0.25	①	-	-
Type 1180 Aluminum	4 Oz.							
Type 1130 Steel	1 lb., 10 Oz.	2.50	2.25	2.75	2.00	②	0.25	0.50
Type 1182 Aluminium	10 Oz.					0.12	0.62	
Type 1138 Steel	3 lb., 6 Oz.	2.87	3.19	3.48	2.69	②	0.25	0.75
Type 1185 Aluminum	1 lb., 4 Oz.		3.06	3.50				

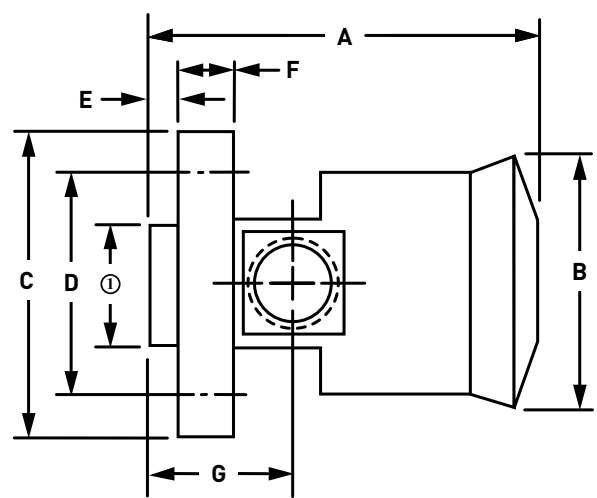

① Male Flange
1.099 OD x 0.77 ID

Dimensional Diagram: 1133 Ammonia Distributor with Auxiliary Side Connection

No. Circuits & Tubing Sizes Available	Approximate Net Weight	Dimensions (Inches)						
		A	B	C	D	E	F	G
Type 1133 Steel	2 lb., 10 oz	3.44	2.25	2.75	2.00	0.25	0.50	1.25

Appendix B

Refrigerant Distributors

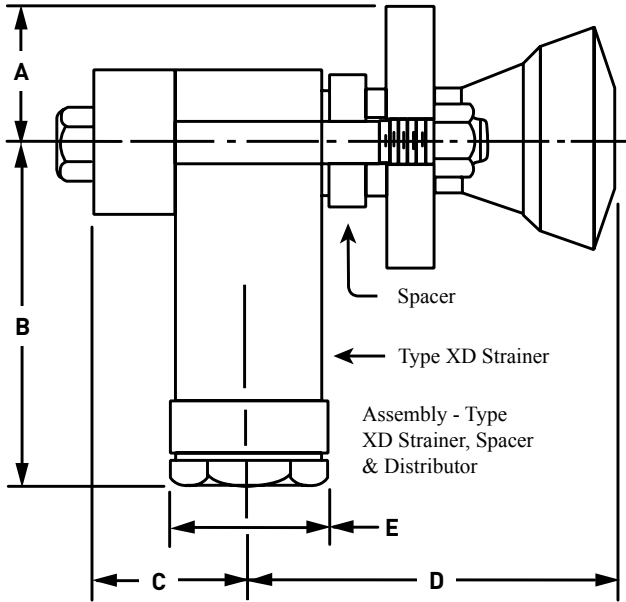

Dimensional Diagram: Aluminum Flange No. 207651 for Type 1180 Distributor

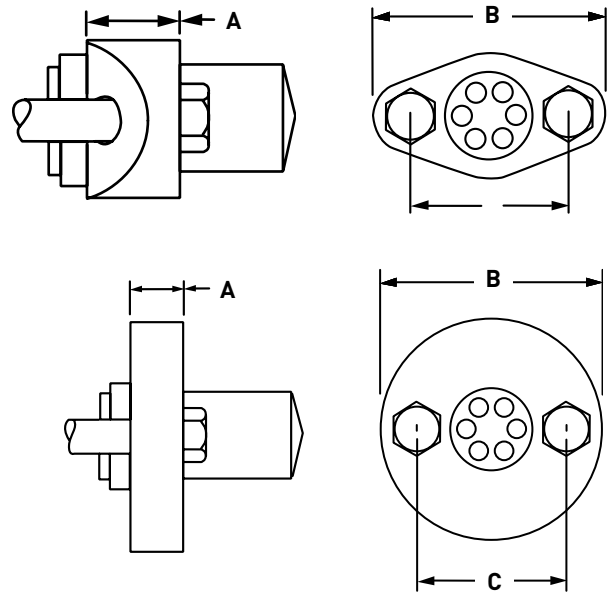

Dimensional Diagram: Steel Flange No. 207560 for Type 1132 and 1180 Distributors

Type	Dimensions - Inches				
	A	B	C	D	E
1132	0.19	3.50	1.19	3.44	1.56
1180					
1130					
1133	4.38				
1182	3.44				
1138	1.75	4.00	4.75	4.12	2.75
1185					

Type	Dimensions - Inches		
	A	B	C
207651	0.62	3.00	2.00
207650	0.94		

Appendix B

HJH and XOP Solenoid Valves

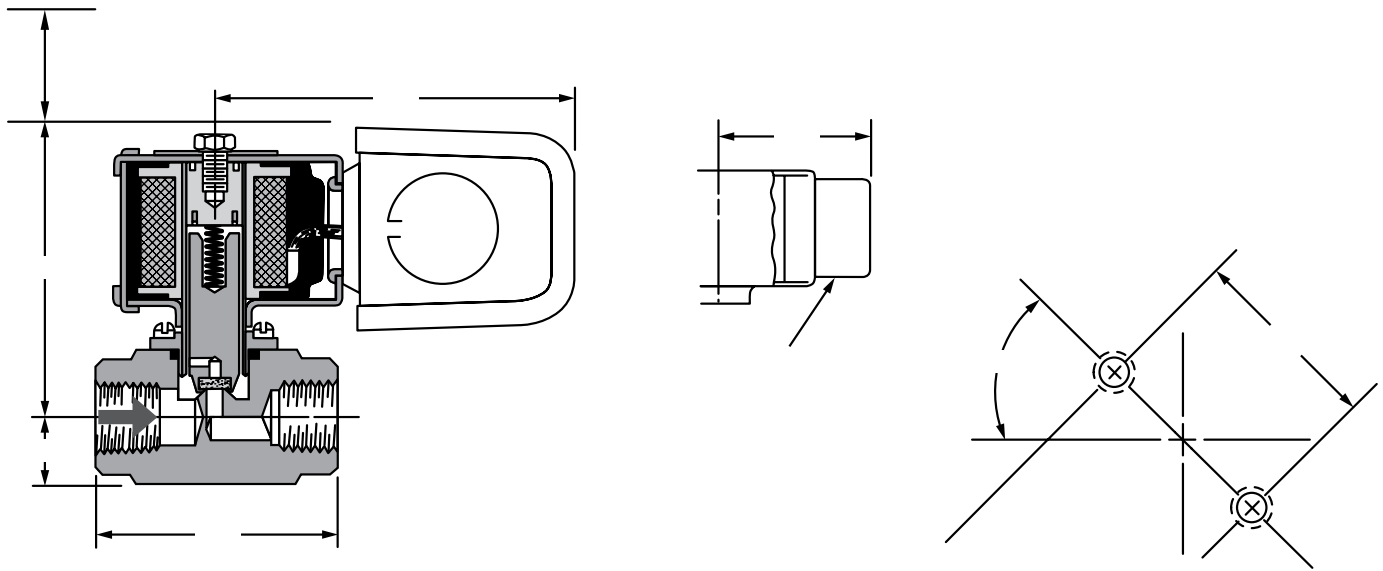

Core Filter Dryer

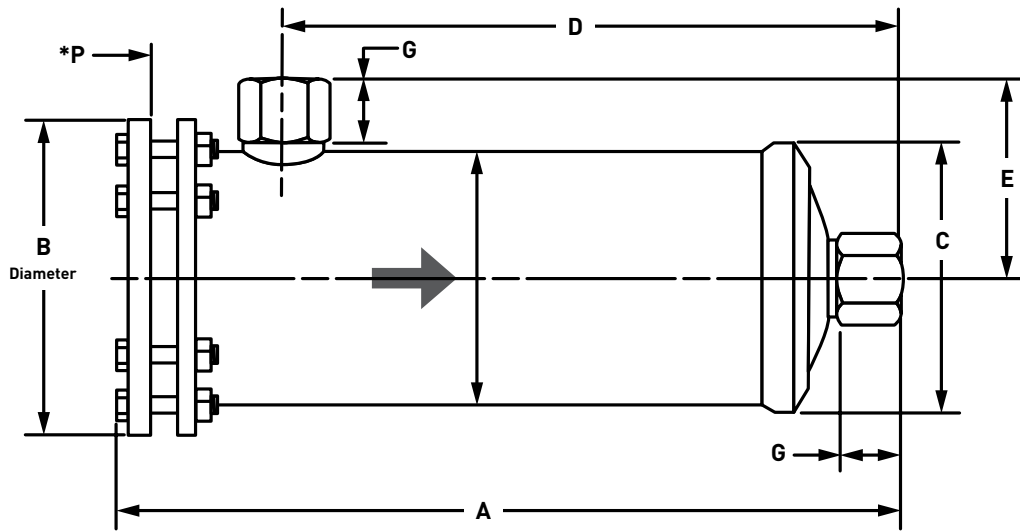

Dimensional Diagram: Core Filter Dryer

Type	Connections (Inches)	Shell Dimensions Inches								Net Weight (lbs)	Shipping Weight (lbs)
		A	B	C	D	E	F	G	*P		
C-484-P	½ FPT	9.08	6.00	5.00	5.85	3.41	4.75	-	7.50	10	12
C-966-P	¾ FPT	14.67			11.44	3.48			13.00	14	16
C-1448-P	1 FPT	20.42			17.19	3.66			18.62	17	20
C-19212-P	1½ FPT	25.85			22.62	3.76			24.25	20	23
C-40016-P	2 FPT	34.44	7.50	6.25	30.38	4.38	6.00	-	32.12	46	51

* "P" Dimension is the pull space required to change core.

Strainers

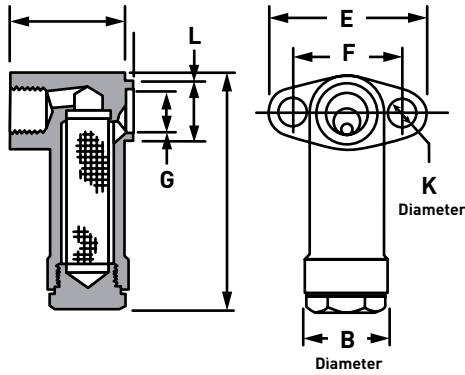

Dimensional Diagram: "XD" Strainer

Type	Weight (lbs)		Dimensions (Inches)								
	Net	Shipping	A	B	C	E	F	G	H	K	L
XD 074	1¾	3	4.19	1.50	2.25	2.88	2.00	0.78	1.09	0.50	0.13

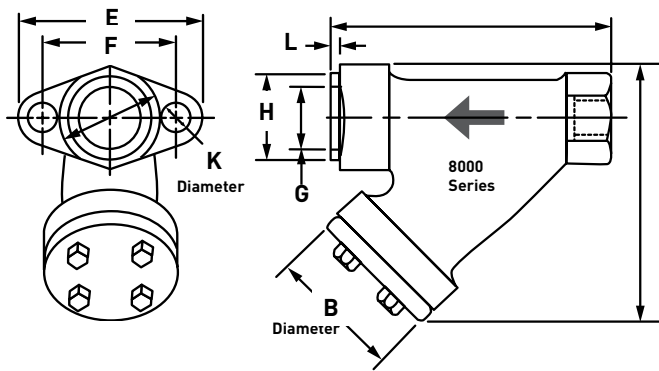

Dimensional Diagram: 8000 Series Strainer

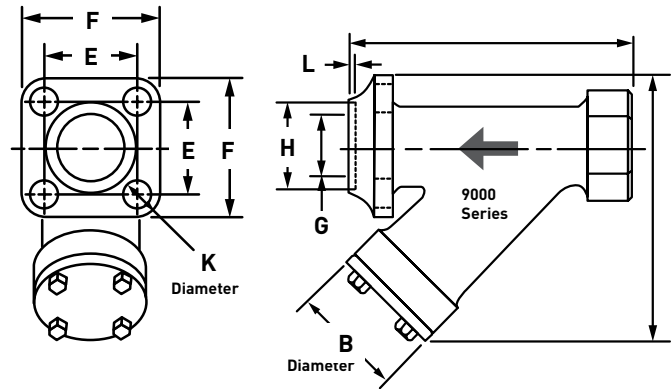

Dimensional Diagram: 9000 Series Strainer

Type	Weight - (lbs)		Dimensions (Inches)									
	Net	Shipping	A	B	C	D	E	F	G	H	K	L
8004	5	7	5.69	2.75	5.6	2.06	3.81	2.69	1.28	1.75	0.56	0.13
8006												
9008	11	13	7.56	31.3	7.50	—	2.44	3.75	1.81	2.31	0.75	
9010	10½											

Sight Glass (SA K87 & SA K90)

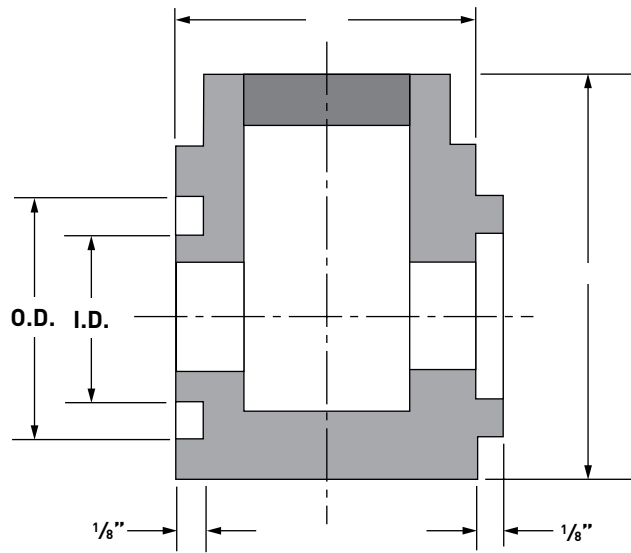

Constant Pressure Expansion Valve (PDA)

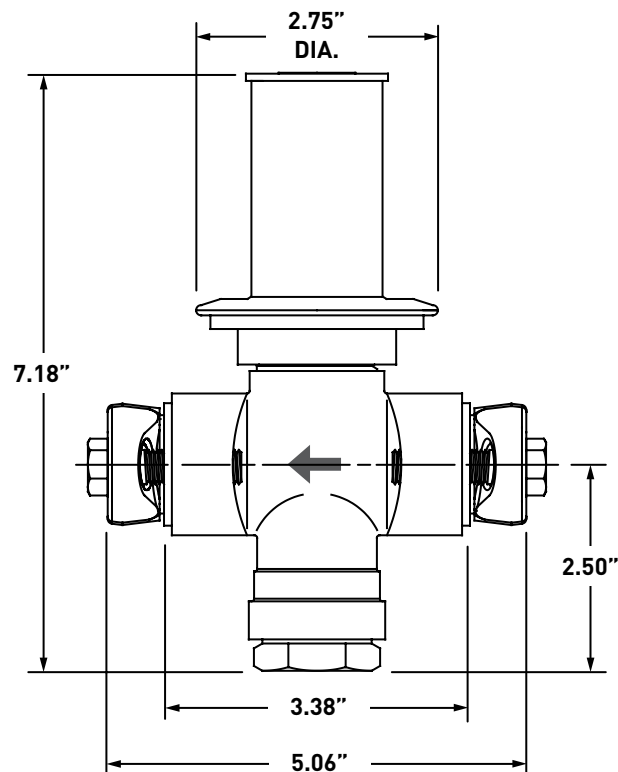

A P P E N D I X

Valve Bolt Torque Specifications

Check Valves	<u>217</u>
Hand Shut-Off and Hand Expansion Vavles	<u>217</u>
Pressure Regulators	<u>217</u>
Solenoid Valves	<u>218</u>
Strainers	<u>218</u>

Valve Bolt Torque Recommendations

Check Valves

CK-1 & CK-2 Check Valves					
Port Size		Bolt Size	Item Description	Torque	
mm	inch			mkg	ft. lb.
20 - 25	¾ - 1	–	Valve Cover	14	100
20 - 25	¾ - 1	–	Piston Disc Retaining Nut	2.1	15
32	1¼	¼" - 20	Piston Set Screws	1.4	10
32 - 65	1¼ - 2½	⅝" - 18	Valve Cover Screws	2.1	15
75 - 125	3 - 5	⅝" - 11	Valve Cover Screws	10	75
150	6	¾" - 10	Valve Cover Bolts	15	105

CK-3 In-Line Check Valves				
Port Size		Item Description	Torque	
mm	inch		mkg	ft. lb.
13 - 25	½ - 1	Valve Seat Assembly	Contact + 1/4 turn	
13 - 25	½ - 1	Valve Body Cap	2.1	15

CK-5 Check Valves					
Port Size		Bolt Size	Item Description	Torque	
mm	inch			mkg	ft. lb.
32 - 150	1¼ - 6	⅝" - 18	Cover Screws	2.1	15
32 - 150	1¼ - 6	⅝" - 11	Adapter Screws	10	75
–	–	¼" - 20	A2D/S6B/S6A Screws	1.1	8.0
125 - 150	5 - 6	¾" - 10	Valve Seat Assembly	10	75

CK-2D & CK-6D Check Valves					
Port Size		Bolt Size	Item Description	Torque	
mm	inch			mkg	ft. lb.
40 - 65	1⅝ - 2½	⅜" - 16	Cover Screws	4.1	30
40 - 65	1⅝ - 2½	⅝" - 18	Bore Plate Screws	2.1	15
75 - 100	3 - 4	⅝" - 11	Cover/Bore Plate Screws	10	75
–	–	¼" - 20	A2D/S6B/S6A Screws	1.1	8.0

S6A Solenoid Tube Assembly				
Type	Item Description	Torque		
		mkg	ft. lb.	
S6A	Tube Assembly with Aluminum Gasket	15	110	
S6A	Tube Assembly with Wolverine Gasket	8.3	60	
S6B	Tube Assembly	2.1	15	

A2D Pilot Regulators			
Bolt Size	Item Description	Torque	
		mkg	ft. lb.
⅝" - 18	Bonnet Screws	2.1	15
–	Pilot Seat and Seal Insert	2.8	20
¼" - 20	A2D Screws	1.1	8.0

Pressure Regulators Valves

A2A, A2B, & A4A Pressure Regulators					
Port Size		Bolt Size	Item Description	Torque	
mm	inch			mkg	ft. lb.
20 - 100	¾ - 4	⅝" - 18	Bonnet Screws	2.1	15
20 - 100	¾ - 4	–	Pilot Seat and Seal Insert	2.8	20
20 - 100	¾ - 4	¼" - 20	A2D/S6A/Moduplate Screws	1.1	8.0
20 - 32	¾ - 1¼	–	Bottom	21	150
40 - 65	1⅝ - 2½	½" - 13	Bottom Cover Screws	6.9	50
75 - 100	3 - 4	⅝" - 11	Bottom Cover Screws	10	75
20 - 65	¾ - 2½	⅝" - 18	Adapter Screws	2.1	15
75 - 100	3 - 4	⅝" - 11	Adapter Screws	10	75

A4W Pressure Regulators					
Port Size		Bolt Size	Item Description	Torque	
mm	inch			mkg	ft. lb.
125 - 150	5 - 8	–	Pilot Seat and Seal Insert	2.8	20
125 - 150	5 - 8	⅝" - 18	Bonnet Screws	2.1	15
125 - 150	5 - 8	¼" - 20	A2D/S6A/Moduplate Screws	1.1	8.0
125 - 150	5 - 8	¾" - 10	Adapter Bolts	15	105
125 - 150	5 - 8	–	Main Valve Seat Ring	14	100
125 - 150	5 - 8	⅝" - 18	Seat Retaining Screw	2.1	15

Flow Regulators				
Type	Bolt Size	Item Description	Torque	
			mkg	ft. lb.
AFR-3	⅝" - 18	Cover Screws	2.1	15
FFR-2	–	Valve Cap	12 - 14	90 - 100

S6A Solenoid Tube Assembly				
Type	Item Description	Torque		
		mkg	ft. lb.	
S6A	Tube Assembly with Aluminum Gasket	15	110	
S6A	Tube Assembly with Wolverine Gasket	8.3	60	

Valve Bolt Torque Recommendations

Solenoid Valves

S4A & S9 Valves					
Port Size		Bolt Size	Item Description	Torque	
mm	inch			mkg	ft. lb.
20 - 100	3/4 - 4	-	Same as S8F Solenoid Tube Assembly (see table below)		
20 - 100	3/4 - 4	-	Seat Assembly	2.8	20
20 - 32	3/4 - 1 1/4	-	Bottom	21	150
40 - 65	1 5/8 - 2 1/2	1/2" - 13	Bottom Cover Screws	6.9	50
75 - 100	3 - 4	5/8" - 11	Bottom Cover Screws	10	75
20 - 65	3/4 - 2 1/2	5/16" - 18	Adapter Screws	2.1	15
75 - 100	3 - 4	5/8" - 11	Adapter Screws	10	75

S4W & S9W Solenoid Valves					
Port Size		Bolt Size	Item Description	Torque	
mm	inch			mkg	ft. lb.
125 - 150	5 - 8	-	Pilot Seat and Seal Insert	2.8	20
125 - 150	5 - 8	-	Same as S8F Solenoid Tube Assembly (see table below)		
125 - 150	5 - 8	5/16" - 18	Bonnet Screws	2.1	15
125 - 150	5 - 8	3/4" - 10	Adapter Bolts	15	105
125 - 150	5 - 8	-	Main Valve Seat Ring	14	100
125 - 150	5 - 8	5/16" - 18	Seat Retaining Screw	2.1	15

S4AD Valves					
Port Size		Bolt Size	Item Description	Torque	
mm	inch			mkg	ft. lb.
20 - 100	3/4 - 4	-	Same as S6A Solenoid Tube Assembly (see table below)		
20 - 32	3/4 - 1 1/4	-	Bottom	21	150
40 - 65	1 5/8 - 2 1/2	3/8" - 16	Cover Screws	4.1	30
40 - 65	1 5/8 - 2 1/2	5/16" - 18	Bore Plate Screws	2.1	15
75 - 100	3 - 4	5/8" - 11	Cover/Bore Plate Screws	10	75
-	-	1/4" - 20	A2D/S6B/S6A Screws	1.1	8.0

Solenoid Tube Assembly				
Type	Item Description	Torque		
		mkg	ft. lb.	
S6N, S6A, S8F	Tube Assembly with Aluminum Gasket	15	110	
S6N, S6A, S8F	Tube Assembly with Wolverine Gasket	8.3	60	
S6N, S6A	Seat Assembly	2.8	20	
S7A	Tube Assembly	21	150	
S5A	Tube Assembly with Aluminum Gasket	15	110	
S5A	Tube Assembly with Wolverine Gasket	8.3	60	

Strainers

RSF Strainers					
Port Size		Bolt Size	Item Description	Torque	
mm	inch			mkg	ft. lb.
13	1/2	-	Strainer Cap	8.3	60
25 - 32	1 - 1 1/4	5/16" - 18	Cover Screws	2.1	15
50 - 100	2 - 4	3/8" - 16	Cover Screws	4.1	30 Max.
25 - 100	1 - 4	3/8" FPT	Drain Connection	Firm	Firm

RSW Strainers					
Port Size		Bolt Size	Item Description	Torque	
mm	inch			mkg	ft. lb.
125 - 200	5 - 8	3/4" - 10	Cover Bolts	15	105
125 - 200	5 - 8	3/8" FPT	Drain Connection	Firm	Firm

Hand Shut-Off and Expansion Valves

Hand Shut-Off and Expansion Valves						
Port Size		Bolt Size	Torque			
mm	inch		Bonnet Screws		Packing Nut	
		mkg	ft. lb.	mkg	ft. lb.	
6 - 13	1/4 - 1/2	5/16" - 18	2.6	19	0.4	2.5
20 - 25	3/4 - 1	5/16" - 18	2.6	19	0.4	2.5
32 - 40	1 1/4 - 1 1/2	3/8" - 16	4.3	31	0.4	2.5
50	2	7/16" - 14	6.2	45	0.4	2.5
65	2 1/2	1/2" - 13	8.3	60	0.4	2.5
75	3	1/2" - 13	10	75	0.4	2.5
100	4	5/8" - 11	19	140	0.9	6.7
125 - 200	5 - 8	5/8" - 11	19	140	0.9	6.7

Suggested Flange Tightening Instructions for Manufacturer's Instructions

Verify that piping into which a valve or flange is to be installed is properly supported and aligned. Be certain that the mating surfaces of the gasketed joints are parallel, aligned and perpendicular to the pipe axis, in good condition and free of debris and corrosion. Use only undamaged gaskets suitable for service in an ammonia refrigerating system. Verify that all the nuts, bolts, cap screws and washers meet Parker's requirements for the application and tighten progressively in a diametrically staggered pattern. Leak test upon completing the installation.

For more information please reference the IAR 2-2008 Section 10.

A P P E N D I X

Valve Classification: Pressure Equipment Directive (PED)

Valve Classification: Pressure Equipment Directive

Valve Classifications According to Pressure Equipment Directive 97/23/EC

PED compliant product can be ordered with standard flanges made from ASTM A105 forged steel.

Products in FLUID GROUP I, Category I, II, IV will carry CE mark and notified body number. Products in FLUID GROUP II, Category I, will carry CE mark.

* Sound Engineering Practice

Fluid Group I (Ammonia)

Valve Type	Port Size	Categories				
		SEP*	I	II	III	IV
Regulators						
A2A	N/A	✓				
A2B	N/A	✓				
A2CK	N/A					✓
A4A Adaptomode	DN 20 - 25	✓				
	DN 32		✓			
	DN 40 - 100			✓		
A4W	DN 125			✓		
Solenoids						
SV2	DN 13 - 25	✓				
S6N	DN 13	✓				
S8F	DN 13	✓				
S7A	DN 20 - 25	✓				
S4A	DN 20 - 25	✓				
	DN 32		✓			
	DN 40 - 100			✓		
S5A	DN 32		✓			
	DN 40 - 75			✓		
S9W	DN 125			✓		
Strainers						
RSF	DN 13 - 25	✓				
	DN 32		✓			
	DN 40 - 100			✓		
RSW	DN 125			✓		
Check Valves						
CK-4A Inline	DN 13	✓				
	DN 20 - 100			✓		
CK-1 Piston-type	DN 32		✓			
	DN 40 - 100			✓		
CK-2 Gas Powered	DN 32		✓			
	DN 40 - 100			✓		
CK-5 Gas Powered	DN 32		✓			
	DN 40 - 100			✓		
CK-3 Inline	DN 13 - 25	✓				
Hand Valve	DN 10 - 25	✓				
Unibody Valves	DN 5 - 10	✓				
Gauges	ALL	✓				
Flow Regulators						
AFR/FFR	DN 20	✓				
V200 Purger						
Low Temp/High Temp	Assembly		✓			
Level Controls						
LLSS	Assembly					✓
Liquid Drain Ball Valves	DN 13 - 25	✓				

A P P E N D I X

Safety Information

Safety Guide	<u>222</u>
Safety Procedures: Control Valves	<u>224</u>
Safety Procedures: Hand Shut-Off Valves	<u>228</u>

Safety Guide

Selecting and Using Parker Products and Related Accessories

⚠ WARNING: FAILURE OR IMPROPER SELECTION OR IMPROPER USE OF REFRIGERATING SPECIALTIES DIVISION PRODUCTS, ASSEMBLIES OR RELATED ITEMS (“PRODUCTS”) CAN CAUSE DEATH, PERSONAL INJURY, AND PROPERTY DAMAGE. POSSIBLE CONSEQUENCES OF FAILURE OR IMPROPER SELECTION OR IMPROPER USE OF THESE PRODUCTS INCLUDE BUT ARE NOT LIMITED TO:

- Injuries or damage resulting from inhalation or exposure to conveyed fluids
- Injuries from lifting or supporting a heavy item
- Electric shock from contact with live electrically energized components
- Explosion

Before selecting or using any of these Products, it is important that you read and follow the instructions below.

1.0 General Instructions

- 1.1. Scope: This safety guide is designed to cover general guidelines on the installation, use, and maintenance of Refrigerating Specialties Division products (R/S Products).
- 1.2. Fail-Safe: R/S Products can and do fail without warning for many reasons. Design all systems and equipment in a fail-safe mode, so that failure of these products and related accessories will not endanger persons or property.
- 1.3. Distribution: Provide a copy of this safety guide to each person that is responsible for selection, installation, or use of R/S Products. Do not select or use R/S Products without thoroughly reading and understanding this safety guide as well as the specific R/S publications for the products considered or selected.
- 1.4. User Responsibility: Due to the wide variety of operating conditions and applications for R/S Products, Parker and its distributors do not represent or warrant that any particular R/S Product is suitable for any specific end use system. This safety guide does not analyze all technical parameters that must be considered in selecting a product. The user, through its own analysis and testing, is solely responsible for:
 - Making the final selection of the appropriate R/S Product.
 - Assuring that all user’s performance, endurance, maintenance, safety, and warning requirements are met and that the application presents no health or safety hazards.
 - Complying with all existing warning labels and / or providing all appropriate health and safety warnings on the equipment on which the R/S Products are used; and,
 - Assuring compliance with all applicable government and industry standards.
- 1.5. Safety Devices: Safety devices should not be removed or defeated.
- 1.6. Warning Labels: Warning labels should not be removed, painted over or otherwise obscured.
- 1.7. Additional Questions and Information: If you have any additional questions or require further information call 1-708-681-6300 or go to www.parker.com/refspec. Safety Bulletins RSBCV and RSBHV can also be obtained there.

2.0 Product Selection Instructions

- 2.1. Pressure rating: Never exceed the maximum rated pressure sometimes referred to as the design pressure of a refrigeration system. Consult product labeling, R/S catalogs or the instruction sheets supplied with R/S Products for maximum rated pressure.
- 2.2. Temperature rating: Never operate outside the rated temperature limits of an R/S Product. Operating the R/S Product outside the rated temperature limits can result in product failure. Consult R/S Product labeling, R/S catalogs, or the instruction sheets supplied with the R/S Products for maximum and minimum fluid temperature limits
- 2.3. Flow Rate: The flow rate requirements are a primary consideration when designing a refrigeration system. System components need to be able to reliably provide minimum and maximum flow requirements for the desired application. Flow ratings are provided in the R/S catalog.
- 2.4. Environment: Many environmental conditions can affect the integrity and suitability of a product for a given application. R/S Products are designed for use in general purpose industrial applications. Typical refrigerants used with these products are explosive, corrosive, caustic, or greenhouse gases. Compliance with government, industry or environmental standards is required.
- 2.5. Fluid Compatibility: Compatibility references can be found in R/S catalogs or calling 1-708-681-6300 or going to www.parker.com/refspec for any additional questions or information.

3.0 Product Assembly and Installation Instructions

- 3.1. Component Inspection: Prior to assembly or installation a careful examination of these R/S Products must be performed. All R/S Products must be checked for correct style, size, and catalog number. DO NOT use any R/S Product that displays any signs of nonconformance.

Safety Guide

Selecting and Using Parker Products and Related Accessories - Continued

- 3.2. Hydrostatic Expansion: Hydrostatic expansion (thermal expansion due to heating of liquids in a confined space) of liquid refrigerant trapped between refrigeration components can create dangerously high pressures and rupture components. See R/S Product bulletins and installation instructions for more detail on precautions to take to avoid damage or injury.
- 3.3. Installation Instructions: R/S published installation instructions must be followed for installation of R/S Products. These instructions are provided with every R/S Product sold, or by calling 1-800-627-4593, or at www.parker.com/refspec.

4.0 Valve and Accessory Maintenance and Replacement Instructions

- 4.1. Maintenance: R/S Product service life may be significantly reduced without a continuing maintenance program. The severity of the application, risk potential from a component failure, and experience with any known failures in the application or in similar applications should determine the frequency of inspections and the servicing or replacement of R/S Products so that they are replaced before any failure occurs. A maintenance program must be established and followed by the user and, at minimum, must include instructions 4.2 through 4.6.
- 4.2. Installation and Service Instructions: Before attempting to service or replace any worn or damaged parts consult the appropriate Service Bulletin for the R/S Product in question. These service and installation instructions are provided with every R/S Product sold, or are available by calling 1-800-627-4593, or at www.parker.com/refspec.
- 4.3. System Isolation Hazards: Care must be taken when isolating system components for service or replacement. As a guide see the appropriate bulletins published by the International Institute of Ammonia Refrigeration available at www.iiar.org. Also see R/S Safety Bulletins RSBCV and RSBHV available at www.parker.com/refspec for guidelines to avoid potentially dangerous conditions.
- 4.4. Visual Inspection: Any of the following conditions requires immediate system shut down, replacement of worn or damaged components, or correction of any system malfunction. These conditions can mask potentially hazardous situations and should be corrected.
 - Leakage to the atmosphere: Look and listen to see if there are any signs of damage to any of the components in the system.
 - Damaged or degraded components: Look to see if there are any visible signs of wear, component degradation or excessive corrosion.
 - Any observed improper system or component function.
 - Excessive dirt and/or ice build-up.
- 4.5. Service or Replacement Intervals: It is the user's responsibility to establish appropriate service and/or replacement intervals. R/S Products do wear and can deteriorate over time. Environmental conditions can significantly accelerate this process. R/S Products need to be serviced or replaced on routine intervals. Service intervals need to be established based on:
 - Previous performance experiences.
 - Government and/or industrial standards.
 - When failures could result in unacceptable down time, equipment damage or personal injury risk.
- 4.6. Servicing or replacing any worn or damaged parts: To avoid unpredictable system behavior that can cause death, personal injury and property damage:
 - Follow all government, state and local safety and servicing practices prior to service including but not limited to all OSHA Lockout Tagout procedures (OSHA Standard – 29 CFR, Part 1910.147, Appendix A, The Control of Hazardous Energy – Lockout / Tagout).
 - Disconnect electrical supply (when necessary) before installation, servicing, or conversion.
 - Components installed in pressurized refrigerant piping must be isolated from the refrigeration system and the refrigerant safely purged from the component. See 4.3 above.
 - Installation, servicing, and / or conversion of these products must be performed by knowledgeable and qualified personnel.
 - After installation or servicing electrical supplies (when necessary) should be connected and the product tested for proper function and leakage. If leakage is present or if the product does not operate properly, do not put the product or system into use.
 - Warnings and specifications on the product should not be covered or painted over. If masking is not possible, contact your local representative for replacement labels.
 - Putting Serviced System Back into Operation: Follow the guidelines above and all relevant installation and maintenance instructions supplied with the R/S Product to insure proper function of the system.

Safety Procedures

Refrigeration Control Valves

Introduction

This bulletin is a summary of safety procedures for the proper selection, installation, use and maintenance of Refrigerating Specialties Division industrial refrigerant control valves. Additional free copies are available and should be distributed to all concerned personnel. This bulletin is intended to help you protect your personnel, product and plant. Because of space limitations, this bulletin must be supplemented by accepted and known industry safety practices and local code requirements.

Refrigerating Specialties Division control valves are designed and built to the highest standards of the refrigeration industry. However, for proper performance the valves must be correctly chosen, properly installed and periodically serviced. Because safe operation is of primary concern, this bulletin emphasizes suggestions for the safe installation and maintenance of Refrigerating Specialties Valves. Read this information carefully before installing a valve or working on one already installed; also, use it to review all previous installations.

All personnel working on valves must be qualified to work on refrigeration systems. Any person intending to service a valve should completely read this bulletin and the product bulletin describing the particular valve and its operation before any work begins. If there are any questions, contact Refrigerating Specialties before proceeding with the work.

Receiving and Unpacking

All control valves are packed for maximum protection. Unpack carefully. Flange bolts are packed in cotton bags and coils are packed loose. Check the carton to make sure all flanges and other items are unpacked and in agreement with the packing slip. Save the enclosed instructions for the installer and eventual user. Do not remove the protective covering from the inlet and outlet of the control valve until the valve is ready to be installed.

Caution: Do not, at any time, make any alteration or modifications to any Refrigerating Specialties Division valves or regulators without the express and written approval of this company. Threaded parts should not be subjected to excessive torque by use of an oversized wrench, wrench extension or by impacting the wrench handle. Where specified in the individual bulletin, observe the torque requirements for bolts, screws and other threaded parts. Contact the factory for torque values not furnished in current literature.

For extensive repairs on valves or regulators, especially those more than three years old, the valves or regulators should be returned to the factory for thorough inspection and rebuilding. Spare parts should be checked for corrosion before installation. In addition, part numbers should be checked against the latest assembly bulletin to be sure current parts are being used.

If a valve or regulator has failed under circumstances which caused, or could have caused, injury to personnel or damage to property, a replacement valve should not be installed until the reason for the previous failure is determined and corrected. Adequate protection should be taken to prevent both liquid shock and suction shock both upstream and downstream of the valve or regulator.

Liquid Expansion

In liquid lines, or lines that might contain substantial amounts of liquid refrigerant, certain precautions must be taken to avoid damage due to liquid expansion when a section of line is isolated by positive shut off valves. This condition may occur whenever the ambient temperature could be higher than the liquid temperature. This could even occur in a refrigerant or oil line other than a "liquid" line.

Temperature increase in a section with trapped liquid can cause extremely high pressures due to the expanding liquid and possibly rupture a gasket, pipe, or valve. When low temperature liquid lines are used, as in a liquid overfeed (recirculation) system, and the lines or control valves may be exposed to warm ambient conditions, particular care must be taken; liquid expansion can occur very rapidly.

Check Valves

Check valves must never be installed at the inlet of either a solenoid valve, a regulator or a regulator with an electric solenoid pilot shut-off feature. Also, the check valve should not be installed at the inlet of an outlet pressure regulator in a system where liquid may be trapped between the two valves. If a check valve is needed, install it on the outlet side of such valves. Most solenoid valves and regulators will permit reverse flow if the outlet pressure is greater than inlet pressure. If at any time, such reverse pressure conditions are possible and reverse flow is unacceptable a check valve should be installed at the control valve outlet.

All hand valves that could trap liquid when closed must be marked with a warning against accidental closing. The liquid refrigerant must be removed before the hand valves are closed on both sides of a control valve or any other component. Also, liquid must be removed before a hand valve is closed at the inlet of a solenoid valve or a regulator with positive electric shut-off, or some outlet pressure regulators, or at the outlet of a check valve, unless these valves are manually open.

Caution: To protect personnel, product and plant, remove all liquid from the section to be isolated before hand valves are closed. Make sure the control valves are open when removing the liquid. See Service and Maintenance Instructions before attempting to take any valve apart.

Relief Devices

Relief devices or relief methods should be used in all parts of a refrigeration system where liquid can be trapped and liquid expansion could take

Safety Procedures

Refrigeration Control Valves - Continued

place. Under no circumstances should R/S Pressure Regulators be used as a relief to the atmosphere, R/S Type H Safety Relief valves should be used instead.

Selection and Application

A control valve must be selected only by a person having adequate knowledge of the system and of the valve to be chosen. Any Refrigerating Specialties Division control valve must be used only as specifically stated in Refrigerating Specialties Division Catalogs or Bulletins for normal refrigeration applications unless otherwise approved in writing by Refrigerating Specialties Division.

The valves are designed to operate with ammonia and/or halocarbon refrigerants. Valves using flanges with copper connections must not be used with ammonia refrigerant. Unless authorized by the factory, Refrigerating Specialties valves should not be used for refrigerants or fluids not mentioned on the nameplate or in the pertinent bulletin.

Installation

Installation must be done according to all applicable Safety Codes and Standards, and by personnel qualified to install refrigeration systems. Refrigerating Specialties Division control valves must be installed according to the manufacturer's instructions, this bulletin, and the generally known safety practices.

Mounting

ASTM A307 Grade A square headed bolts should be used to mount flanged body valves. They assure the maximum bolt surface and flange engagement. For all lug mounted valves, flange bolts should be inserted in a direction pointing toward the valve body. The bolt should pass first through the mounting flange before engaging the valve flange. Allow proper space for installing the valve. Do not use the valve to "stretch" or "align" the pipe. Using flange bolts to close a large gap can distort the valve or at least stress it unduly, and possibly cause it to malfunction, or the bolts may be damaged or stripped. (See table below for proper torque requirements). For proper sealing the gaskets should be lightly oiled and all bolts must be tightened evenly. Make sure the flange tongues are properly aligned with the grooves in the valve body. Where necessary, support the valve by brackets or hangers to avoid overstressing the pipe or valve.

When mounting weld-end valves: welding procedures for all steel pipe and fitting need to conform to all requirements of the ASME IX and other Pressure Pipe welding standards. In all cases where valves are installed without disassembly, they should be manually opened.

Location

Valves must not be installed in locations where they can be damaged by material handling or other equipment. Control valves should be installed such that the inlet pipe is straight for a minimum of 6 pipe diameters. Trapped ice build-up must be avoided at or between valves and other equipment. Provide reasonable access to all control valves for maintenance purposes.

Insulation

When it is necessary to insulate the control valves, the insulation must be applied to allow access for proper operation and maintenance of the valves. The manual opening and adjusting stems should be easily accessible at all times. In the case of solenoid valves the insulation must not extend to the coil housing or coil burnout may occur. Insulation should be constructed so that sections can be easily removed and replaced to allow the valve to be disassembled. Insulation applied to strainers should provide ready access for cleaning the strainer basket.

Since most maintenance problems caused by dirt occur at the start-up of a system, it is advisable to delay insulating the control valves and strainers until the system has operated for several days. During that time the strainers should be checked for dirt and cleaned as necessary. Cotton bags are available for 25mm - 100mm (1" - 4") Type RSF Strainers to improve their ability to remove small particles of dirt during start-up.

Pump Out Means

Individual valves or control stations should be provided with means for pumping out or safely purging the refrigerant.

Pressure Testing

Every segment of a refrigeration system, including control valves, should be field pressure tested before system is insulated and put in use. Make sure that correct high and low side test pressures are used. Use proper refrigerant or gas for pressure testing; that is do not use halocarbons or CO₂ to test an ammonia system, nor use ammonia to test halocarbon system. Never use the compressor in a system to build up pressure for testing.

In pressure testing Range V, VA, A, B or D pressure regulators, test pressure in excess of 21. kg/cm² (300 psig) may cause setting shift and diaphragm may deform enough to require replacement after the test. If the above conditions exist, contact the factory for proper solution.

Electrical

Only properly qualified electricians should handle the electrical portions of control valves and their circuitry. All power supplies

Safety Procedures

Refrigeration Control Valves - Continued

and wiring must be adequate to provide the proper voltage and current to the solenoid coils. The power supply must be capable of providing the proper in-rush current. Never energize the solenoid with the coil housing or plunger assembly removed.

Service and Maintenance

All systems require maintenance and service. The personnel doing the work must be qualified and completely familiar with the system they are to work on or all other precautions will be meaningless.

Pump Out

For the protection of personnel, product, and plant, all refrigerant possible must be removed from a valve or any other component of the system, before any refrigerant retaining part is loosened. Before opening a valve, make sure all refrigerant liquid has been removed. In particular, beware of strainers and other sections of piping which may trap liquid refrigerant which will require a considerable length of time to remove. Pump out as much refrigerant as possible before discharging remaining refrigerant in a properly protected manner. During pump out make sure control valves are opened manually to avoid trapping refrigerant. All type RSF and RSW Strainers are provided with 3/8" FPT connection to assist in pump out.

At times it may be necessary to discharge some small amount of refrigerant from the isolated section. When this becomes necessary, certain precautions must be observed. Make sure control of discharge rate can be easily maintained and that a quick shut-off is available.

Refrigerant should be discharged into and disposed of in a proper container accepted by applicable safety codes and standards. Discharge of refrigerant to atmosphere should be avoided. Never discharge any refrigerant into an area without sufficient ventilation, or into an area where open flame or electrical spark is present. Any oil in the refrigerant may cause a mist that could cause a fire or explosion. Halocarbon refrigerant should not be discharged into areas where open flame is present, since toxic gases may form. Ammonia should not be discharged into occupied areas, or areas containing product affected by ammonia. In the case of ammonia, discharge any vapor left into a container of cold water, making sure that the discharge hose remains submerged at all times. (Be sure that no pressure reversals can occur that may pull water into the system.) Water may have to be refreshed to absorb all the ammonia; about one gallon of fresh water is needed for one pound of ammonia. To prevent pulling excessive air and moisture into a system, avoid opening the system when it is under vacuum.

Caution: Do not attempt to work on any part of a refrigeration system without having help nearby and observing. Use safety glasses or a safety face shield for added safety to protect the eyes. Protective equipment should be readily available and all personnel involved should be thoroughly trained in its use. Personnel should be especially protected against falling because they may be startled by escaping refrigerant. Always make sure that there is a way out and that everyone can leave the area fast. When seal caps cover manual opening or adjusting stems, the caps must be removed with caution because liquid refrigerant could accumulate under such a cap. Avoid contact with any liquid refrigerant.

Electrical

Before working on any valve or other item having electrical components refer to the "ELECTRICAL" paragraph of the "INSTALLATION" section. Be sure the circuits are completely de-energized; just throwing a switch may not be sufficient. Failure to do this may result in personal injury or damage to solenoid coils or other components. Take care to see that the circuits cannot be energized accidentally. Never energize the solenoid with the coil housing or plunger assembly removed.

Disassembly

Be sure that any person working on a valve is familiar with its construction and operation by referring to the proper bulletin. Make sure the pressure in the system to be opened is reduced to, and remains, at atmospheric pressure before valve pressure containment seals are released. A pressure gauge should be connected to the part of the system to be evacuated. Before removing the bonnet of pressure regulators, back out adjusting stem to prevent damage to the diaphragm.

Re-assembly

Be sure all parts are clean and free of moisture before reassembly. Damaged parts and gaskets should be replaced. It is advisable to purge the section of air before opening it to the rest of the system. When opening hand valves, ensure that initial refrigerant flow will be in the normal direction of valve flow; this will avoid backflow and possible damage to the strainer if one is used.

Dirt, Contamination, and Corrosion

Protect the valves from foreign material during storage and installation. The protective plugs on the valve openings should remain in place until the valves are ready to be installed. Once a section of a system is installed, and before it is put into operation, it is advisable to charge it with appropriate refrigerant or suitable inert gas to avoid corrosion. Avoid exposure of R/S valves to halogenated solvents or similar reactive fluids. External corrosion over a long period of time must be controlled by painting and replacement of corroded parts.

Strainer Maintenance

Strainer inspection is of utmost importance, especially the first few hours, days or weeks after the start-up. Foreign material should be removed and the screens should be washed with proper solvent. Strainer inspection and cleaning should be continued until dirt accumulation ceases. Later, any time a valve pressure containment seal is released for service or maintenance, its companion strainer should also be inspected and

Safety Procedures

Refrigeration Control Valves - Continued

cleaned. Filter bags are available for 25mm - 100mm (1" - 4") Type RSF Strainers to improve their ability to remove small particles of dirt during start-up. If a strainer filter bag is used in the strainer basket, the cloth bag must be checked every few days depending upon the amount of system dirt collected. When the cloth bag no longer collects dirt, it must be discarded.

General Specifications

Refrigerating Specialties refrigerant containing valves and strainers are designed for a Maximum Rated Pressure of 21 bar (300 psig) except where shown otherwise on the nameplate. They are suitable for use under most temperature conditions encountered in refrigeration systems. If either fluid or ambient temperature is below a valves rated minimum, consult the factory. In addition, should fluid temperature exceed the rated maximum or should ambient temperatures exceed 125° F., consult the factory.

Safety Procedures

Refrigeration Hand Shut-Off Valves

Introduction

This bulletin is a summary of safety procedures for the proper installation, use and maintenance of Refrigerating Specialties Division industrial refrigerant valves. Additional free copies are available and should be distributed to all concerned personnel. This bulletin is intended to help you protect your personnel, product and plant. Because of space limitations, this bulletin must be supplemented by accepted and known industry safety practices and local code requirements.

Refrigerating Specialties Division hand valves are designed and built to the highest standards of the refrigeration industry. However, for proper performance, the valves must be properly installed and maintained. Because safe operation is of primary concern, this bulletin emphasizes suggestions for the safe installation and maintenance of Refrigerating Specialties Valves. Read this information carefully before installing a valve or working on one already installed. It should also be used to review all previous installations.

All personnel working on valves must be qualified to work on refrigeration systems. Any person intending to service a valve should completely read this bulletin and the product bulletin describing the particular valve and its application and disposition before any work begins. If there are any questions, contact Refrigerating Specialties before proceeding with the work.

Receiving and Unpacking

All valves are packed for maximum protection. Unpack carefully. Check the carton to make sure all items are unpacked and in agreement with the packing slip. Save the enclosed instructions for the installer and eventual user. Do not remove the protective covering from the inlet and outlet of the valve until the valve is ready to be installed.

Caution: Do not, at any time, make any alteration or modifications to any Refrigerating Specialties Division valves without the express and written approval of this company. Threaded parts should not be subjected to excessive torque by use of an oversized wrench, wrench extension, or by impacting the wrench handle. Where specified in the individual bulletin, observe the torque requirements for bolts, screws and other threaded parts. Contact the factory for torque values not furnished in current literature.

Spare parts should be checked for corrosion before installation. In addition, part numbers should be checked against the latest assembly bulletin to be sure current parts are being used.

If a valve has failed under circumstances which caused, or could have caused, injury to personnel or damage to property, a replacement valve should not be installed until the reason for the previous failure is determined and corrected.

Liquid Expansion

In liquid lines or lines that might contain substantial amounts of liquid refrigerant, certain precautions must be taken to avoid damage due to liquid expansion when a section of line is isolated by positive shut off valves. This condition may occur whenever the ambient temperature could be higher than the fluid temperature. This could even occur in a refrigerant or oil line other than a "liquid" line.

Temperature increase in a section with trapped liquid can cause extremely high pressures due to the expanding liquid and possibly rupture a gasket, pipe, or valve. When low temperature liquid lines are used, as in a liquid overfeed (recirculation) system, and the lines may be exposed to warm ambient conditions, particular care must be taken. It should be noted that liquid expansion can occur very rapidly in a line.

Hand Valves

All hand valves that could trap liquid when closed must be marked with a warning against accidental closing. The liquid refrigerant must be removed before the hand valves are closed on both sides of a control valve or any other component. Also, liquid must be removed before a hand valve is closed at the inlet of a solenoid valve or a regulator with positive electric shut-off, or some outlet pressure regulators, or at the outlet of a check valve, unless these valves are manually open.

Caution: To protect personnel, product and plant, remove all liquid from the section to be isolated before hand valves are closed. Make sure the control valves are open when removing the liquid. See Service and Maintenance Instructions before attempting to take any valve apart.

Hand Valve Installation Requirements

Installation must be done according to all applicable Safety Codes and Standards, and by personnel qualified to install refrigeration systems. Refrigeration Specialties Division valves must be installed according to the manufacturer's instructions, this bulletin, and the generally known safety practices in the industry.

Hand Valves should be installed such that seal caps, opening stems or hand wheels are accessible, that stem movement remains unrestricted, and with sufficient surrounding clearances that the incorporation into the pipeline is unchallenged. For the FPT-connected valves, this means full rotation of the valve plus sufficient clearance to permit a wrench to engage the hexagonal portions of the valve body for tightening to the desired orientation.

Welding procedures for all steel pipe and fittings need to conform to all requirements of the ASME (Section B31.5 and IX), API, and other applicable piping codes.

Safety Procedures

Refrigeration Hand Shut-Off Valves - Continued

R/S recommends against the use of compressed air for leak testing. While many successful installations have employed compressed air, the effects of moisture and oxygen, both short and long term, on system interior condition, integrity, and performance are too significant to make it preferable to a dry nitrogen test. It has been established by investigation of failure modes, that certain chemicals will infiltrate the discontinuities in a chilled weld and reside there, setting up corrosion products. Oxygen entrapped in such notch sites, combined with the presence of ammonia, will promote stress corrosion cracking in a relatively short period. R/S recommends that leak testing be applied with dry nitrogen and that the elevated pressure be reduced to near-atmospheric only shortly before the evacuation process is started. The segment should subsequently be evacuated to no more than 750 Micron and the refrigerant then be introduced promptly to a pressure well above atmospheric. Repeated cycles of breaking the vacuum with Dry Nitrogen and re-establishing it, is highly recommended.

R/S's Hand Valve offerings incorporate high-temperature Carbon Extended PTFE as seat disc. This material has a stability temperature over 420 °F. and therefore, under most circumstances, permits the installer to weld a valve into the pipeline without first removing the bonnet. Removing pipe debris and the spatter consequence of the welding becomes more difficult when installing a valve in this way, so the incorporation of backing rings or the employment of socket weld valves is encouraged. Even with that, installation processes and procedures need to address the intent to remove all possible debris from the piping section.

In all cases where valves are installed without disassembly, the Valve disc should be in a mid stroke position while welding. This precludes contact and limits the heat conducted from the body to the seat ring on the disc and avoids any arcs between the beveled seat of the body and the disc assembly. Actual body temperatures achieved during welding cannot be predicted precisely because they vary with welding current and technique, length of adjacent piping, the sequence in which joints are made, the energy input from any adjacent components, the application and flow of any purging gas, and so on. In the absence of a cooling purge gas stream, R/S recommends that the bonnet be removed from a valve should the length of pipe to be connected to the valve be less than 5-times the pipe diameter. All such temperature profiles change considerably should either side of the adjacent piping be insulated or otherwise restrained from freely conducting away the heat from welding.

The potential for interference with material and components yet to be installed such as insulation, electrical equipment, and structural additions for maintenance access or equipment protection, need to be considered. The completed construction overall should be arranged to preclude the potential for contact with moving part machinery, material handling equipment, and similar conditions. Valves on cold lines will often accumulate frost and /or drip moisture. The location and orientation of service valves should consider all these potential conditions.

Stem Seal Design

Along with the temperature tolerant Seal Ring material, R/S's Hand Valves are furnished with Dual O-Ring Stem Seals. This arrangement minimizes frictional force on the stem, and rotational torque is very low. Combined with the wiping and forming action of the conical seat bead, the overall result is a very low hand wheel or actuator force required for complete sealing. This also reduces the effect of creep or shrink. In most cases, this precludes any need to retighten the valve.

A packing on the wetted side of the O-Ring Gland wipes the stem free of dirt or debris from the system side. It also provides a final safety margin such that should the O-Rings be contaminated in any fashion, the packing nut can be tightened down to engage this packing and renew the stem seal. This results in a valve that requires considerably different user inputs to actuate particularly as compared to other valves remaining entirely intact, and should not be considered an acceptable long-term condition. Repair and renewal should be affected as soon as possible.

Whether specified with the Hand Wheel or Seal Cap arrangement, the torque required to seat the valve is minimal and should never be applied in excess of the maximum values listed in the attached table. Back seating torque is also minimized by employing a knife edge against a beveled portion of the stem; the diameter of the seat is just greater than that of the stem threads, which prevents extraction of the stem even in the case of mechanical failure.

Mounting

Allow proper space for installing the valve. Where necessary, support the valves by brackets or hangers to avoid overstressing the pipe or valve.

Location

Valves must not be installed in locations where they can be damaged by material handling or other equipment. Trapped ice build-up must be avoided at or between valves and other equipment. Provide reasonable access to all control valves for maintenance purposes.

Insulation

When it is necessary to insulate the valves, the insulation must be applied to allow proper operation and maintenance of the valves. The actuator stems should be easily accessible at all times. Insulation should be constructed so that sections can be easily removed and replaced to allow the valve to be disassembled. Since most maintenance problems caused by dirt occur at the start-up of a system, it is advisable to delay insulating the valves until the system has operated for several days.

Pump Out Means

Individual valves or control stations should be provided with means for pumping out or safely purging the refrigerant.

Safety Procedures

Refrigeration Hand Shut-Off Valves - Continued

Dirt and Corrosion

Protect the valves from foreign material during storage and installation. The protective plugs on the valve openings should remain in place until the valves are ready to be installed. Once a section of a system is installed, and before it is put into operation, it is advisable to charge it with proper refrigerant or suitable inert gas to avoid corrosion. External corrosion over a long period of time must be controlled by painting and replacement of corroded parts.

Pressure Testing

Every segment of a refrigeration system should be field pressure tested before the system is insulated and put in use. Make sure that correct high and low side test pressures are used. Use proper refrigerant or gas for pressure testing; that is do not use halocarbons or CO₂ to test an ammonia system, nor use ammonia to test halocarbon system. Never use the compressor in a system to build up pressure for testing.

Service and Maintenance

All systems require maintenance and service. The personnel doing the work must be qualified and completely familiar with the system they are working on or all other precautions will be meaningless.

Caution: Do not attempt to work on any part of a refrigeration system without having help nearby and observing. Use safety glasses or a safety face shield to protect the eyes. Protective equipment should be readily available and all personnel involved should be thoroughly trained in its use. Personnel should be especially protected against falling because they may be startled by escaping refrigerant. Always make sure that there is a way out and that everyone can leave the area fast. When seal caps cover manual opening or adjusting stems, the caps must be removed with caution because liquid refrigerant could accumulate under such a cap. Avoid contact with any liquid refrigerant.

Pump Out

For the protection of personnel, product, and plant, all refrigerant possible must be removed from a valve or any other component of the system, before any refrigerant retaining part is loosened. Before opening a valve, make sure all refrigerant liquid has been removed. In particular, beware of strainers and other sections of piping which may trap liquid refrigerant which will require a considerable length of time to remove. Pump out as much refrigerant as possible before discharging remaining refrigerant in a properly protected manner. During pump out, make sure control valves are opened manually to avoid trapping refrigerant. All type RSF and RSW Strainers are provided with 3/8" FPT connection to assist in pump out.

At times, it may be necessary to discharge some small amount of refrigerant from the isolated section. When this becomes necessary, certain precautions must be observed. Make sure control of discharge rate can be easily maintained and that a quick shut-off is available.

Refrigerant should be discharged into and disposed of in a proper container accepted by applicable safety codes and standards. Discharge of refrigerant to atmosphere should be avoided. Never discharge any refrigerant into an area without sufficient ventilation, or into an area where open flame or electrical spark is present. Any oil in the refrigerant may cause a mist that could cause a fire or explosion.

Halocarbon refrigerant should not be discharged into areas where open flame is present, since toxic gases may form. Ammonia should not be discharged into occupied areas, or areas containing product affected by ammonia. In the case of ammonia, discharge any vapor left into a container of cold water, making sure that the discharge hose remains submerged at all times. (Be sure that no pressure reversals can occur that may pull water into the system.) Water may have to be changed to absorb all the ammonia; about one gallon of fresh water is needed for one pound of ammonia.

To prevent ingress of excessive air and moisture into a system, avoid opening the system when it is under vacuum.

Disassembly

Be sure that any person working on a valve is familiar with its construction and operation by referring to the proper bulletin. Make sure the pressure in the system to be opened is reduced to, and remains, at atmospheric pressure before opening the valve. A pressure gauge should be connected to the section of the system to be evacuated.

Re-Assembly

Be sure all parts are clean and free of moisture before re-assembly. Damaged parts and gaskets should be replaced. It is advisable to purge the section of air before opening it to the rest of the system. When opening hand valves, always open the valve to the inlet of the control valve first; this will avoid back flow and possible damage to the strainer if one is used.

General Specifications

Refrigerating Specialties refrigerant containing valves and strainers are designed for a Maximum Rated Pressure of 27.6 bar (400 psig) except where shown otherwise on the nameplate. They are suitable for use under most temperature conditions encountered in refrigeration systems. Maximum and minimum fluid temperatures for each valve are published in R/S Condensed Catalog CC I I c. If either fluid or ambient temperature is below a valve's rated minimum, consult the factory. In addition, should fluid temperature exceed the rated maximum or ambient temperatures exceed 125° F., please consult factory.

The valves are designed to operate with ammonia and/or halocarbon refrigerants. Unless authorized by the factory, Refrigerating Specialties valves should not be used for refrigerants or fluids not mentioned on the nameplate or in the pertinent bulletin.

Notes

Notes

Notes

Notes

Temperature • Pressure Chart

Temp. °C	Pressure (barg)								R407C	
	R717	R404A	R507	R134A	R22	R410A	CO ₂			
								Liquid	Vapor	
-52	-0.65	-0.25	-0.23	-0.75	-0.43	-0.03	5.27	-0.30	-0.52	
-48	-0.55	-0.08	-0.06	-0.68	-0.30	0.19	6.38	-0.14	-0.39	
-44	-0.44	0.11	0.14	-0.60	-0.14	0.45	7.63	0.05	-0.24	
-40	-0.30	0.34	0.37	-0.50	0.04	0.74	9.03	0.27	-0.07	
-36	-0.13	0.60	0.64	-0.38	0.25	1.08	10.59	0.53	0.14	
-32	0.07	0.90	0.95	-0.25	0.49	1.47	12.33	0.82	0.37	
-28	0.30	1.24	1.30	-0.09	0.77	1.92	14.25	1.15	0.65	
-24	0.57	1.62	1.69	0.10	1.08	2.42	16.36	1.53	0.97	
-20	0.89	2.06	2.13	0.31	1.44	2.99	18.68	1.96	1.33	
-16	1.25	2.54	2.63	0.56	1.84	3.63	21.22	2.44	1.74	
-12	1.66	3.08	3.18	0.84	2.29	4.35	24.00	2.98	2.21	
-8	2.14	3.69	3.80	1.16	2.79	5.14	27.01	3.59	2.73	
-4	2.67	4.35	4.48	1.51	3.35	6.02	30.29	4.25	3.32	
0	3.28	5.09	5.23	1.91	3.97	6.99	33.84	4.99	3.97	
2	3.61	5.48	5.63	2.13	4.30	7.52	35.72	5.39	4.32	
4	3.96	5.90	6.06	2.36	4.65	8.07	37.68	5.81	4.70	
6	4.33	6.33	6.50	2.61	5.01	8.64	39.71	6.25	5.09	
8	4.72	6.78	6.96	2.86	5.40	9.24	41.82	6.70	5.50	
10	5.14	7.26	7.45	3.13	5.80	9.87	44.01	7.18	5.94	
14	6.03	8.27	8.48	3.72	6.65	11.22	48.64	8.21	6.87	
16	6.52	8.81	9.03	4.03	7.11	11.93	51.09	8.75	7.37	
18	7.03	9.37	9.61	4.36	7.59	12.68	53.64	9.32	7.89	
20	7.56	9.96	10.21	4.70	8.09	13.46	56.28	9.92	8.44	
22	8.12	10.57	10.83	5.07	8.61	14.28	59.02	10.54	9.01	
24	8.71	11.21	11.48	5.44	9.15	15.12	61.86	11.18	9.61	
26	9.33	11.87	12.15	5.84	9.71	16.01	64.82	11.86	10.24	
28	9.98	12.55	12.86	6.26	10.30	16.93	67.90	12.56	10.89	
30	10.66	13.27	13.59	6.69	10.91	17.88	71.12	13.28	11.57	
34	12.11	14.79	15.13	7.61	12.20	19.90	—	14.82	13.02	
36	12.89	15.59	15.95	8.11	12.88	20.98	—	15.64	13.80	
38	13.70	16.42	16.80	8.62	13.59	22.09	—	16.48	14.60	
40	14.54	17.28	17.68	9.15	14.32	23.24	—	17.36	15.44	
42	15.42	18.18	18.60	9.71	15.08	24.44	—	18.26	16.31	
44	16.34	19.10	19.54	10.29	15.87	25.68	—	19.20	17.21	
46	17.30	20.06	20.53	10.89	16.69	26.97	—	20.18	18.16	
48	18.29	21.06	21.54	11.52	17.54	28.31	—	21.19	19.13	
50	19.33	22.09	22.60	12.17	18.41	29.69	—	22.23	20.15	
52	20.40	23.16	23.69	12.84	19.32	31.13	—	23.31	21.21	
54	21.52	24.27	24.82	13.54	20.26	32.61	—	24.43	22.31	
56	22.68	25.42	26.00	14.27	21.23	34.15	—	25.58	23.45	
58	23.89	26.60	27.21	15.02	22.23	35.75	—	26.77	24.63	
60	25.14	27.84	28.47	15.80	23.26	37.41	—	28.00	25.86	
64	27.79	30.43	31.14	17.45	25.43	40.90	—	30.59	28.46	
66	29.18	31.80	32.55	18.32	26.57	42.74	—	31.94	29.84	
68	30.63	33.23	34.01	19.22	27.75	44.65	—	33.34	31.28	

Temp. °F	Pressure (psig)								R407C	
	R717	R404A	R507	R134A	R22	R410A	CO ₂			
								Liquid	Vapor	
-60	18.6	6.4	5.8	21.8	11.9	0.2	79.9	7.9	14.5	
-55	16.6	2.9	2.2	20.3	9.2	2.5	91.1	4.5	11.9	
-50	14.3	0.5	0.9	18.7	6.1	5.0	103.4	0.8	9.0	
-45	11.7	2.6	3.0	16.9	2.7	7.7	116.6	1.7	5.7	
-40	8.8	4.9	5.4	14.8	0.6	10.8	131.0	3.9	2.0	
-35	5.4	7.5	8.1	12.5	2.6	14.1	146.5	6.4	1.0	
-30	1.6	10.3	11.0	9.8	4.9	17.8	163.1	9.2	3.3	
-25	1.3	13.4	14.1	6.9	7.4	21.9	181.0	12.2	5.8	
-20	3.6	16.8	17.6	3.7	10.2	26.3	200.2	15.6	8.5	
-15	6.2	20.5	21.4	0.0	13.2	31.2	220.8	19.2	11.5	
-10	9.0	24.6	25.5	1.9	16.5	36.5	242.7	23.2	14.9	
-5	12.2	28.9	30.0	4.1	20.1	42.2	266.1	27.5	18.5	
0	15.7	33.7	34.8	6.5	24.0	48.4	291.0	32.2	22.5	
5	19.6	38.8	40.1	9.1	28.3	55.2	317.6	37.3	26.9	
10	23.8	44.3	45.7	11.9	32.8	62.4	345.7	42.8	31.6	
15	28.4	50.2	51.8	15.0	37.8	70.3	375.6	48.7	36.7	
20	33.5	56.6	58.3	18.4	43.1	78.7	407.2	55.1	42.3	
25	39.0	63.4	65.3	22.1	48.8	87.7	440.7	62.0	48.3	
30	45.0	70.7	72.7	26.1	55.0	97.4	476.1	69.3	54.8	
35	51.6	78.6	80.7	30.4	61.5	107.7	513.4	77.2	61.8	
40	58.6	86.9	89.2	35.0	68.6	118.8	552.9	85.6	69.4	
45	66.3	95.8	98.3	40.1	76.1	130.6	594.5	94.6	77.4	
50	74.5	105.3	108.0	45.4	84.1	143.2	638.3	104.2	86.1	
55	83.4	115.3	118.3	51.2	92.6	156.5	684.4	114.4	95.3	
60	92.9	126.0	129.2	57.4	101.6	170.7	733.1	125.2	105.2	
65	103.2	137.3	140.7	64.0	111.2	185.8	784.2	136.7	115.7	
70	114.2	149.3	153.0	71.1	121.4	201.8	838.1	148.8	127.0	
75	125.9	162.0	165.9	78.7	132.2	218.7	894.9	161.7	138.9	
80	138.4	175.4	179.6	86.7	143.6	236.5	954.9	175.3	151.6	
85	151.8	189.5	194.1	95.2	155.7	255.4	1018.4	189.7	165.1	
90	166.1	204.5	209.3	104.3	168.4	275.4	—	204.8	179.3	
95	181.2	220.2	225.4	113.9	181.8	296.4	—	220.8	194.4	
100	197.3	236.8	242.3	124.2	195.9	318.5	—	237.6	210.4	
105	214.4	254.2	260.1	135.0	210.8	341.9	—	255.3	227.4	
110	232.5	272.5	278.8	146.4	226.4	366.4	—	273.9	245.2	
115	251.6	291.8	298.5	158.4	242.8	392.3	—	293.5	264.1	
120	271.9	312.1	319.2	171.2	260.0	419.4	—	314.0	284.0	
125	293.3	333.3	340.9	184.6	278.0	447.9	—	335.4	305.0	
130	315.8	355.6	363.8	198.7	296.9	477.9	—	357.9	327.1	
135	339.6	379.1	387.8	213.6	316.7	509.4	—	381.5	350.5	
140	364.7	403.7	413.0	229.2	337.4	542.5	—	406.2	375.1	
145	391.0	429.6	439.5	245.7	359.0	577.3	—	431.9	401.0	
150	418.7	456.8	467.4	262.9	381.7	613.9	—	458.9	428.3	
155	447.8	485.5	497.0	281.0	405.3	652.4	—	487.0	457.2	
160	478.3	515.8	—	300.0	430.1	692.8	—	516.4	487.7	

Numbers in red are in inches of mercury (Hg)

Conversion:

1°C = 1.8 + 32 = °F	1 kPa = 0.295 inches Hg	kcal/hr = 3.31•10 ⁻⁴ ton	1 mm ² = 0.0016 in ²	1 m ² /s = 10.753 ft ² /s	1 ton _{refrigeration} = 200 Btu/min	1 ATM = 0.98 bar
Δ(°/s)°C = Δ1°F	1 bar = 29.41 inches Hg	1 bar = 14,503 psi	1 m = 39.37 in	Kv = 0.865 Cv	1 ton _{refrigeration} = 12000 Btu/hr	1 m ³ = 264.17 gal
1 W = 3.412 Btu/hr	1 kW = 1.341 hp	1 kPa = 0.145 psi	1 m = 3.281 ft		psia = psig +14.504	1 m ³ /hr = 4.403 GPM
1 kJ = 0.9478 Btu	1 kW = 0.284 ton	1 mm = 0.03937 in	1 kg = 2.205 lbs		1 inches Hg = 2.04 psig	

Regulator, Solenoids, & Check Valves			
Valve Type	Port Size	Min. PSI Drop to Open	Manual Open Position
A4A	3/4" - 4"	Varies	OUT
A4W	5" - 8"	Varies	IN
A2B	1/4" - 3/4"	Varies	N/A
A2A	1/4" - 3/4"	Varies	N/A
AFR-3	1/2" - 3/4"	Varies	N/A
FFR-2	1/2" - 3/4"	Varies	N/A
S6N	3/16"	0	IN
S8F	1/2"	1	IN
S4A	3/4" - 1 1/4"	4	OUT
S4A	1 5/8" - 4"	2	OUT
S4W	5" - 8"	0	IN
S7A	3/4" - 1"	1	IN
S5A	1 1/4" - 3"	3.5	IN
SV2	1/2" - 1 1/4"	2	IN
S9A	2" - 4"	10	OUT
S9W	5" - 8"	10	IN
CK2	1 1/4" - 6"	0	IN
CK-1	3/4" - 6"	0.5	IN
CK-3	1/2" - 1"	5.0	N/A
CK4A	1/2" - 4"	0.75	N/A
CK4A	5" - 8"	0.6	N/A
Press. Reg.: Stem In - Increases Setpoint Flow Reg.: Stem Out - Increases Flow			

Product specifications subject to change without notice. Visit www.parker.com/refspec for current product information, including the latest version of this catalog.

Parker Hannifin Corporation
Refrigerating Specialties Division
 2445 South 25th Avenue
 Broadview, Illinois 60155-3858 USA
 phone 708 681 6300 • fax 708 681 6306
www.parker.com/refspec

Parker Hannifin Corporation
HERL Refrigerating Specialties Division
 Wankelstrasse 40
 Cologne, Germany D-50996
 phone +49 2236 39 00-0 • fax +49 2236 39 00-39

