

PXV

PXVW

INTRODUCTION

The Hansen PXV and PXVW are pulse modulating liquid refrigerant expansion valves. The PXV uses a specially designed, high-cycle, long life, solenoid operator. A sophisticated 4-20 mA input signal is used to monitor the liquid flow to the system. Unlike traditional TXVs, the pulse design eliminates the need to maintain minimum pressure differential. Low and varying liquid feed pressures (head pressure) are compensated by the basic variable valve operation. It is suitable for use with ammonia and most common refrigerants.

The unique PXVW60 body has an integral 100 mesh (150 micron) strainer screen and features direct weld assembly, eliminating flange gasket leak potential. In addition, the PXVW valve has an adjustable, integral hand-expansion plug to regulate the flow from 15 to 60 nominal tons of ammonia. Consult the factory for PXVW halocarbon capacities.

APPLICATIONS

The PXV modulates the flow of liquid feed to an evaporator or chiller. It is recommended for use wherever a thermal expansion valve (TXV) would be used. It is also ideal for liquid make-up to small surge vessels above flooded heat exchangers to minimize fluctuations in liquid level and evaporator pressures, and for liquid injection for compressor oil cooling.

KEY FEATURES

- PXV5, PXV15 drop-in replacement valve for Sporlan DA series thermostatic expansion valve
- PXV does not require minimum pressure drop to operate; low head pressure tolerant
- PXVW60 with adjustable capacity settings from 15 to 60 nominal tons of ammonia
- Simple, compact controller programmed for liquid level control, liquid injection oil cooling, or DX superheat control
- Operates with 115V, 220V, or 24V AC coil

Specifications, Applications, Service Instructions & Parts

PULSE WIDTH CONTROL EXPANSION VALVE (PXV & PXVW)

Pulse Width Modulated Liquid Level Control, DX Evaporator and Liquid Injection for Refrigerants

CRN
Canadian Registration

PXV

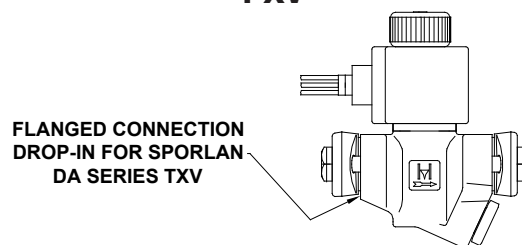

PXVW

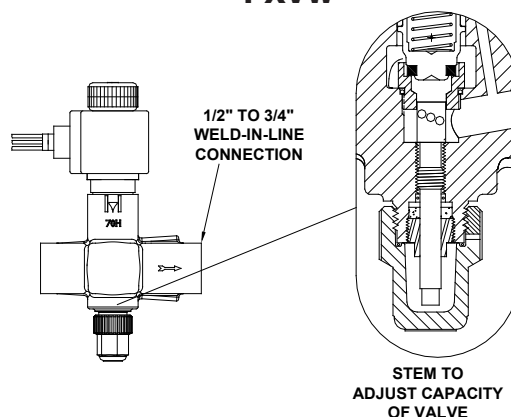

SPECIFICATIONS

Body:

PXV: Ductile iron, ASTM A536 (Flanged Valve)

PXVW: Cast Steel, ASTM A352, grade LCB

Seat Disc: Teflon

Valve Seat: 303 Stainless Steel

Safe Working Pressure:

400 psig (28 bar)

600 psig (40 bar) available upon request

MOPD: 285 psi (19.7 bar)

Refrigerant Temperature: -60°F to +240°F (-50° to 115°C)

Refrigerants: ammonia, R22, R404, R507, R134a, CO₂, and other Hansen approved refrigerants

CAPACITY

The PXV models are available for ammonia capacities up to 60 nominal tons with adjustable capacity settings. The PXV models available for ammonia are 5 and 15 tons (nominal) and the PXVW has an adjustable hand-expansion plug from 15 to 60 tons (nominal).

LIQUID LINE SIZING

Liquid lines should be adequately sized for the capacity of the valve. Listed below are the recommended capacities for liquid lines.

LINE SIZE	MAXIMUM CAPACITY AMMONIA		MAXIMUM CAPACITY R-507	
1/2"	32 Tons	112kW	4 Tons	14kW
3/4"	58 Tons	208kW	8 Tons	28kW
1"	97 Tons	340kW	13 Tons	46kW

NH3 capacities are based on IIAR Refrigeration Piping Handbook tables.

R-507 capacities are based on 3 ft/s liquid velocity. For R-134a, use 160% of R-507 capacity; R-404 140%.

INSTALLATION

Match the arrow on body with system flow direction. The PXV and PXVW may be installed in both horizontal and vertical lines. For DX evaporator, install as close as possible to the distributor in vertical down-flow line (recommended). When installing PXV valve to distributor, remove the expansion orifice plug. Allow 2.2" (57 mm) above the valve for coil removal, 1" (25 mm) below for seal cap removal, and 3" (76 mm) below strainer for screen removal. For proper flange gasket sealing, care must be taken when threading or welding to assure flanges are parallel to each other and perpendicular to the pipe. Also, gaskets should be lightly oiled and all bolts must be tightened evenly.

The PXVW is a weld-in-line valve available in butt weld and socket weld connections. If welding is prolonged enough to overheat the valve body, a wet rag should be wrapped around the valve bonnet and upper body while welding. Socket weld fitting and valve codes require that the pipe be inserted until bottomed against the stop, then backed out approximately 1/16" (1.5 mm) before welding.

Welds should be annealed as necessary in accordance with good practice. Painting valves and welds is recommended for corrosion protection. Pipe covering, where applied, should have a proper moisture barrier. Before putting valves into service, all pipe weld connections, bonnet seals, and stem seals should be tested for leaks at pressure levels called for in appropriate codes.

EVAPORATOR TONNAGE (kW)

CAT NO	CONNECTION		CAPACITY IN TONS (kW)				
	SIZE	STYLE	AMMONIA	R-404/R-507	R-134a	R-22	CO2
PXV5	1/2"	FPT, SW	5 (18)	7 (25)	1 (4)	2 (7)	2 (7)
PXV15	1/2"	FPT, SW	15 (53)	4 (14)	4 (14)	5 (18)	8 (28)
PXVW60	1/2", 3/4"	SW	15 to 60 (53 to 212) ADJUSTABLE	5 to 15 (18 to 53) ADJUSTABLE	5 to 20 (18 to 70) ADJUSTABLE	6 to 27 (21 to 95) ADJUSTABLE	9 to 45 (32 to 158) ADJUSTABLE
	1/2", 3/4", 1"	BW					
	5/8", 7/8", 1-1/8"	ODS					

R-404, R-507, R-134a, and R-22 capacities are based on a pressure drop of 80 psid (6 bar) or higher.

PXV, PXVW AMMONIA EXPANSION CAPACITIES (TONS)

CAT NO	PRESS. DROP (PSI)		20	40	60	80	100	120	140	160
	COND. TEMP (°F)		22°	38°	59°	61°	70°	79°	86°	93°
PXV5	–	0.044 CV	3	3	4	5	5	5	6	6
PXV15	–	0.187 CV	11	14	17	19	21	22	24	25
PXVW60 (ADJUSTABLE ORIFICE)	TURN IN	CV								
	0–1	1.00	57	77	92	103	112	119	126	132
	1½	0.96	55	74	88	99	107	115	121	127
	2	0.87	50	67	80	89	97	104	110	115
	2½	0.65	37	50	60	67	73	78	82	86
	3	0.55	31	43	51	57	62	66	69	72
	3½	0.35	20	27	32	36	39	42	44	46
	4	0.21	12	16	19	22	24	25	26	28
	4½	0.13	7	10	12	13	15	16	16	17
	5–7	0.09	5	7	8	9	10	11	11	12
FULLY IN		MANUALLY OPEN								

Capacities are based on 0°F evaporator and pressure drop. For other evaporator temperatures and corresponding pressure drop the capacities are within 10%.

PXVW60 adjustable for Cv=.10 to 1.0

TYPICAL APPLICATION: DIRECT EXPANSION EVAPORATOR, PXV/PXVW

FIGURE 1

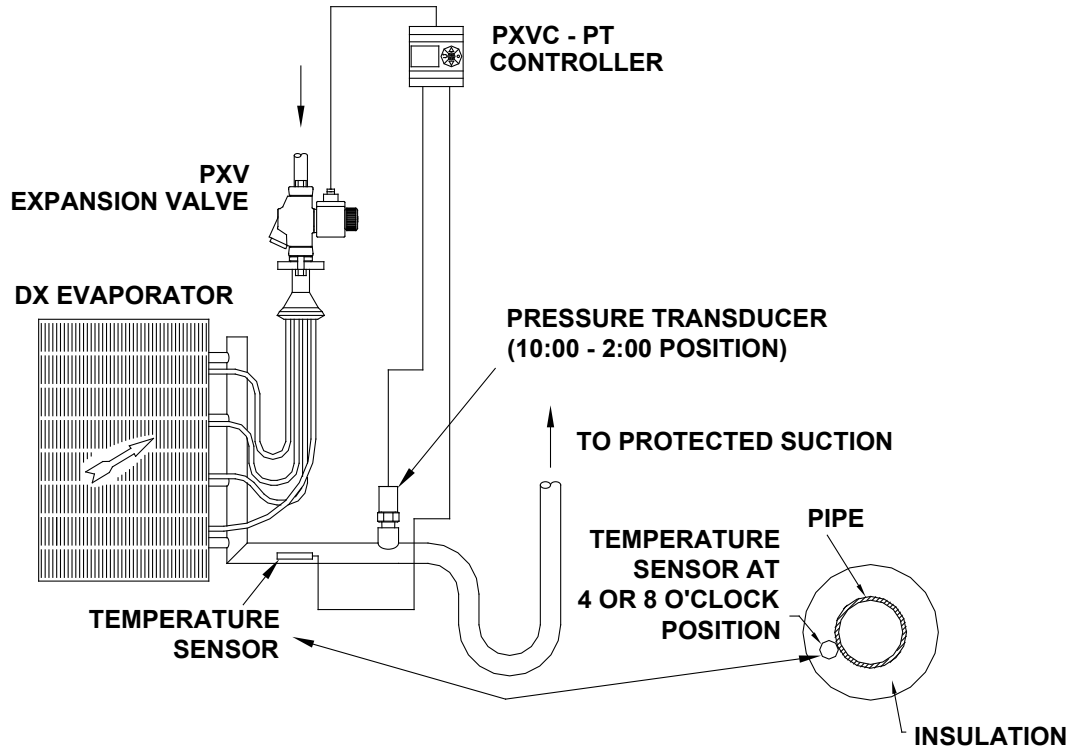
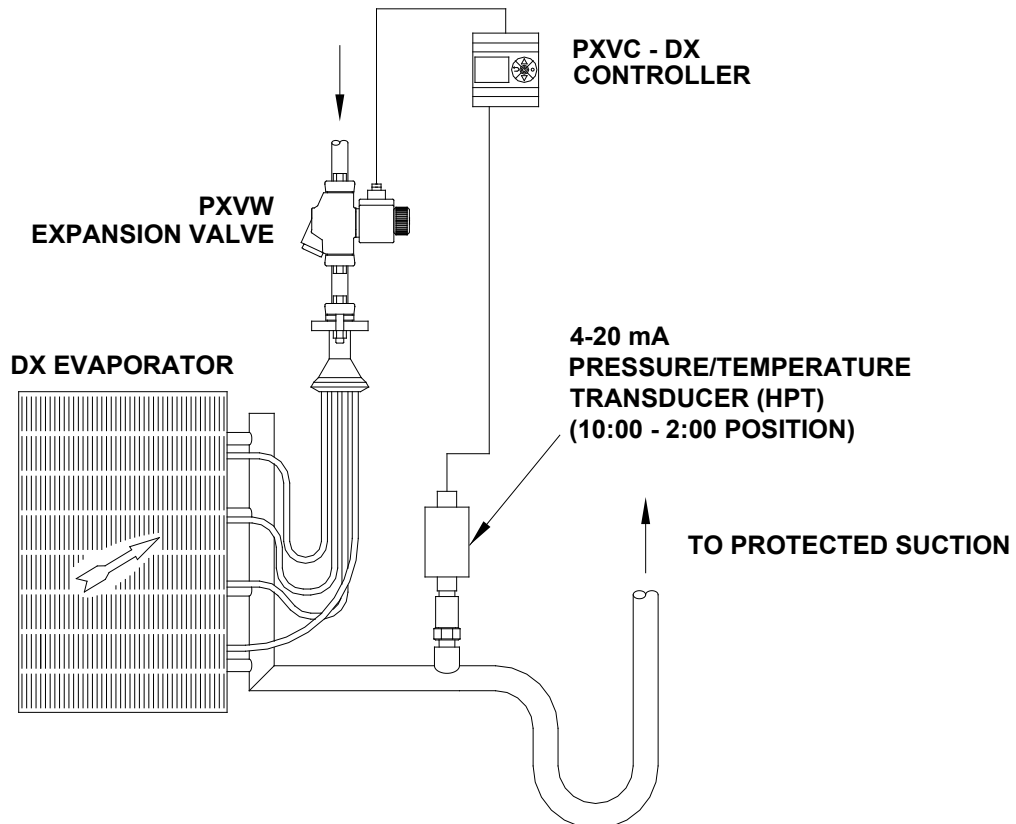

FIGURE 2



OPERATION – LEVEL CONTROL (Figure 3)

The Hansen PXVC-L controller is factory programmed to provide precise control of liquid level in flooded evaporators, small liquid recirculators, and other refrigerant level vessels. A 4-20mA input signal from the Hansen VLT level probe, Hansen Vari-Level with MOD420 Output Module, or other liquid level device to the Hansen PXVC-L controller pulses the PXV valve open and closed at a rate equal to the refrigerant flow necessary to maintain a set-for liquid level in the vessel. For a wiring diagram, refer to Figure 8 on page 9.

OPERATION – LIQUID INJECTION (Figure 4)

The Hansen PXVC-T controller is factory programmed to provide precise control of temperature in applications such as liquid injection to screw compressors. An NTC temperature sensor available from Hansen provides an input signal to the Hansen PXVC-T temperature controller. This controller pulses the PXV valve open and closed at a rate equal to the refrigerant flow necessary to maintain a set-for discharge gas temperature. If valve is controlled with a compressor controller or PLC, the fastest cycle time recommended is once every six seconds for prolonged life. For a wiring diagram, refer to Figure 7 on page 8.

TYPICAL APPLICATIONS – PXV AND PXVW

TYPICAL FLOODED CHILLER APPLICATION

FIGURE 3

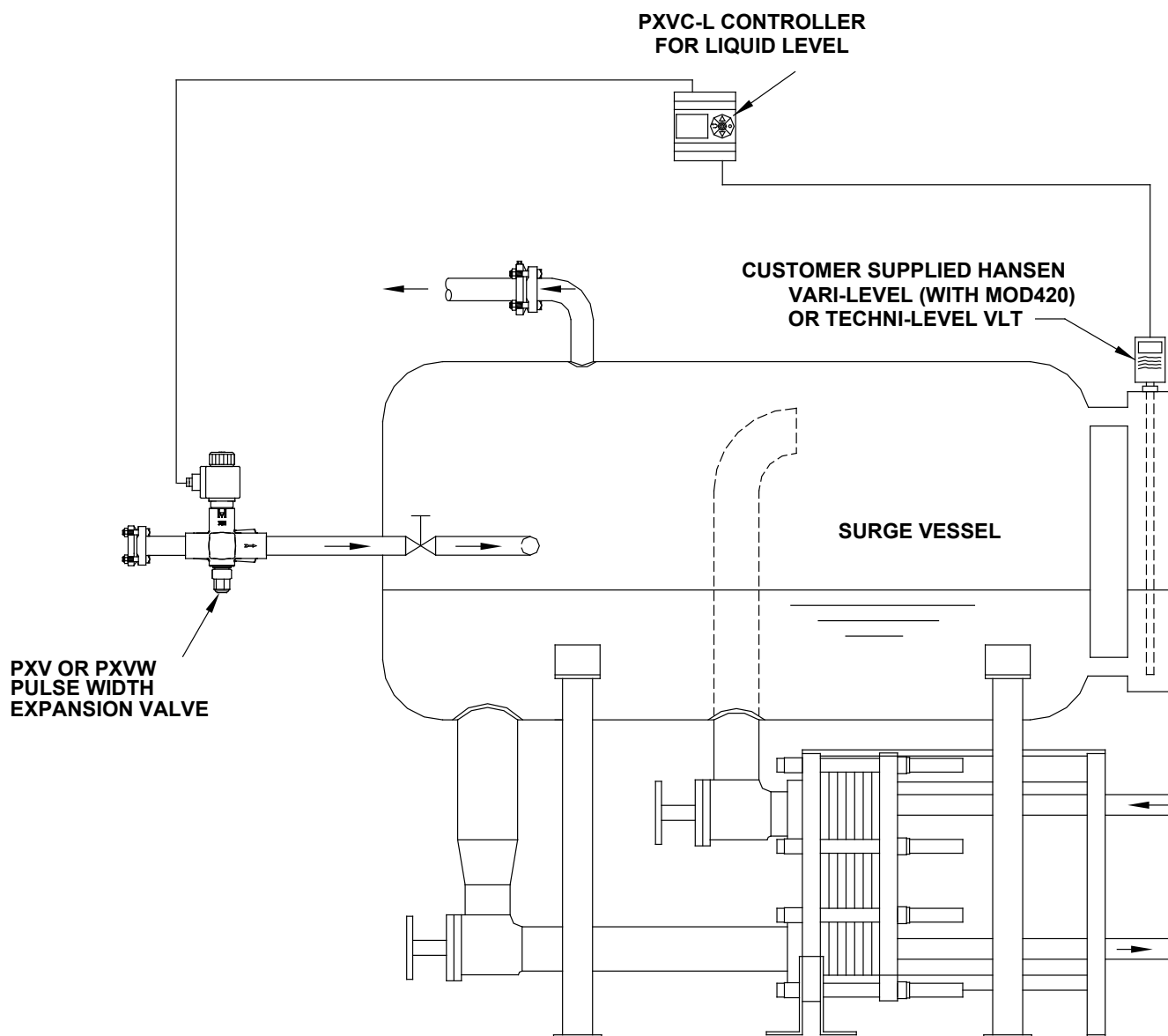

OPERATION – DX EVAPORATOR (Figures 1 & 2)

Through the use of pulse width modulation, the valve is cycled on and off to achieve a desired flow. The recommended fastest cycle time is once every 6 seconds for prolonged life. During a cycle, the valve can be open anywhere from 0 to 6 seconds. The more “on” time required, the greater the flow through the valve. The correct amount of “on” time can be determined by monitoring superheat (see HPT Pressure/Temperature Transducer Bulletin PT100). If actual superheat is greater than desired, the pulse width signal is increased to provide more valve “on” time. If actual superheat is less than desired, the pulse width signal is decreased to reduce valve “on” time. See Figures 5 and 6 on page 6 and 7 for wiring diagrams.

For systems using the PXVW valve, the integral hand-expansion stem capacity must be adjusted to match the capacity of the evaporator. See the chart on page 2 for the approximate settings. During operation, the stem can be adjusted in if it is off too long (capacity setting too high), or out if it is nearly always on (capacity setting is too low).

When using ammonia as the refrigerant, installation should be in the vertical down position directly connected to the distributor. (See Figures 1 & 2). Vertical down installation close to the distributor helps ensure homogenous mixing of gas and liquid entering the evaporator. This is particularly important for applications using multi-circuit, air cooling evaporators. **Note:** Suction lines from DX evaporators should go to a suction trap to protect compressors from liquid carryover that may result from system upsets.

TYPICAL APPLICATIONS – PXV AND PXVW TYPICAL LIQUID INJECTION COOLING FOR SCREW COMPRESSOR APPLICATION

FIGURE 4

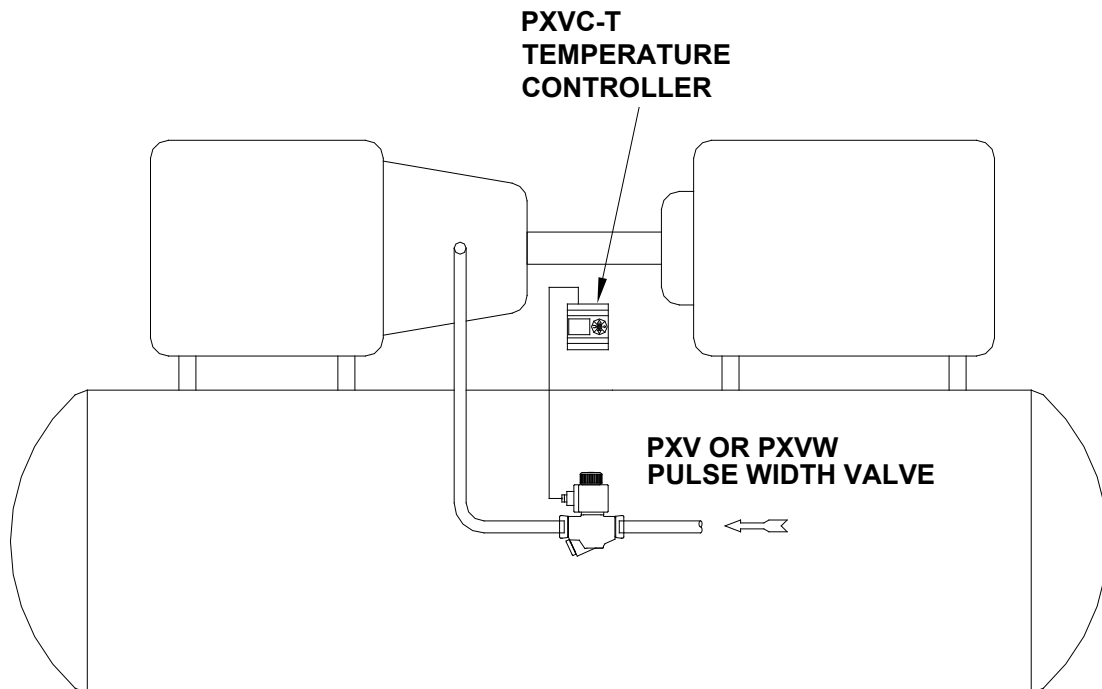

TYPICAL WIRING DIAGRAMS
DX EVAPORATOR CONTROL (PXVC-PT)
 (Using Separate Pressure Transducer and Temperature Sensor)
FIGURE 5

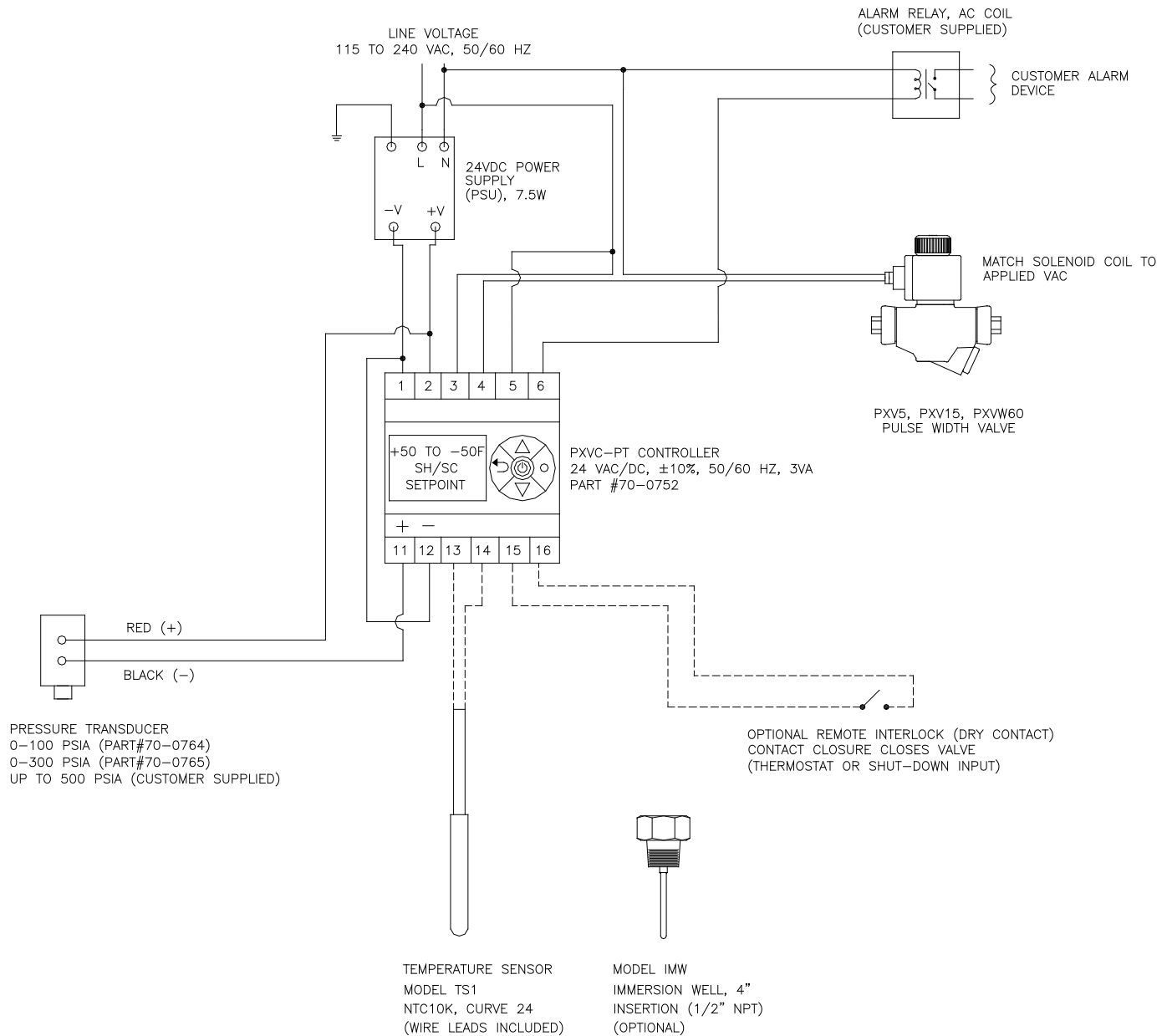

TYPICAL WIRING DIAGRAMS **DX EVAPORATOR CONTROL (PXVC-DX)**

(Using Hansen HPT 4-20 mA or Customer Supplied 4-20 mA Superheat Input)

FIGURE 6

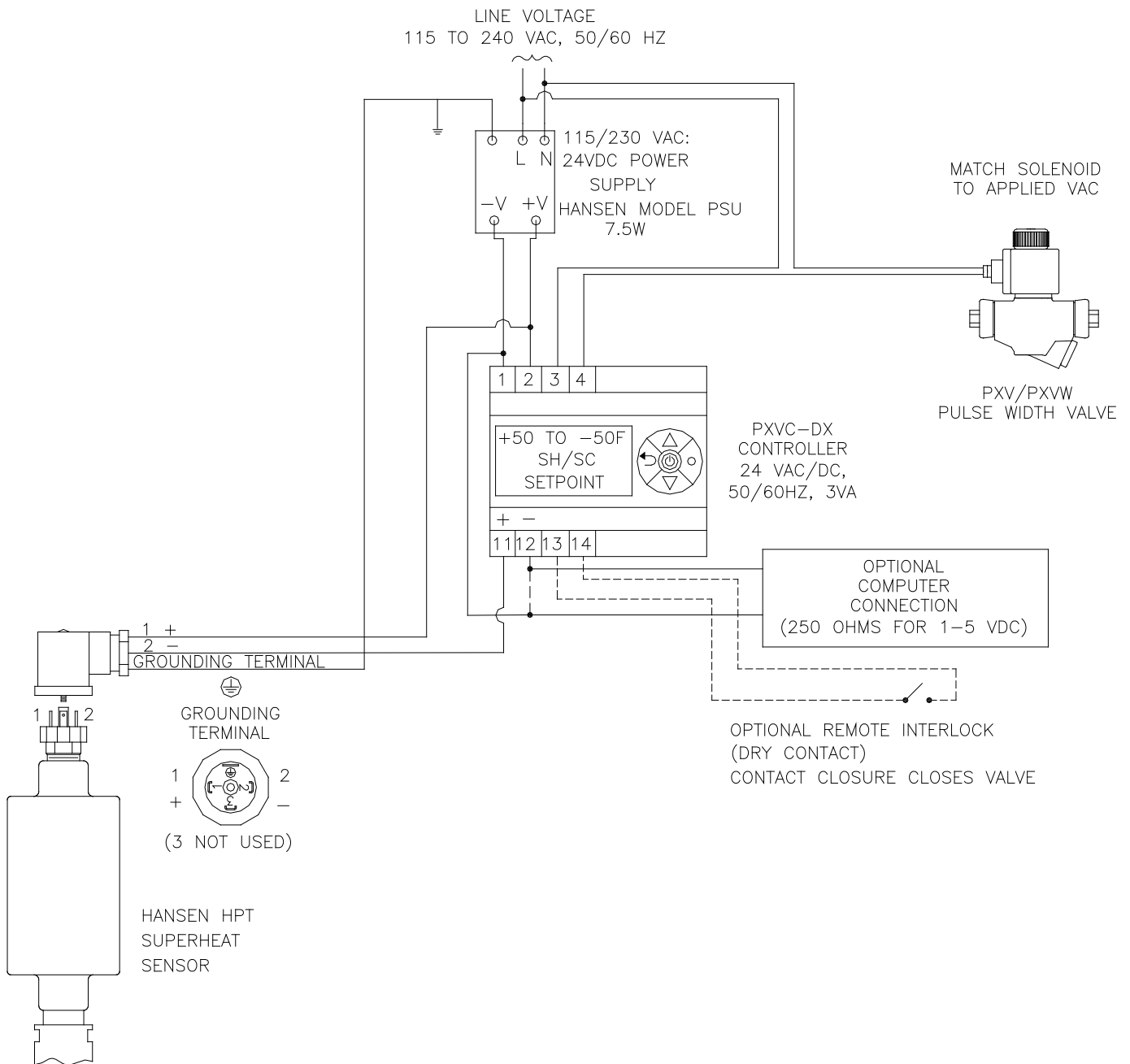

TYPICAL WIRING DIAGRAMS **TEMPERATURE CONTROL** **FIGURE 7**

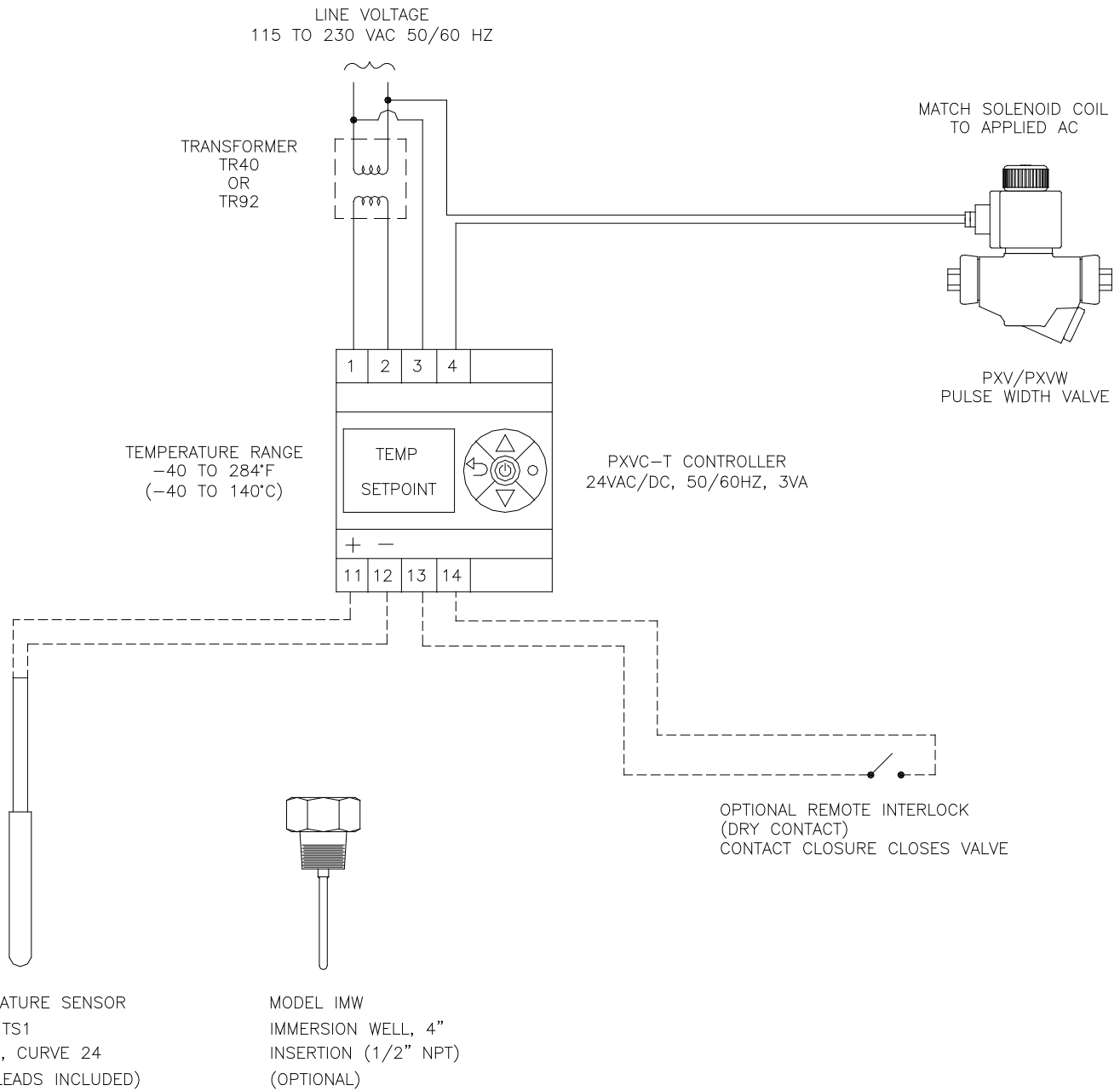

TYPICAL WIRING DIAGRAMS

LIQUID LEVEL CONTROL

FIGURE 8

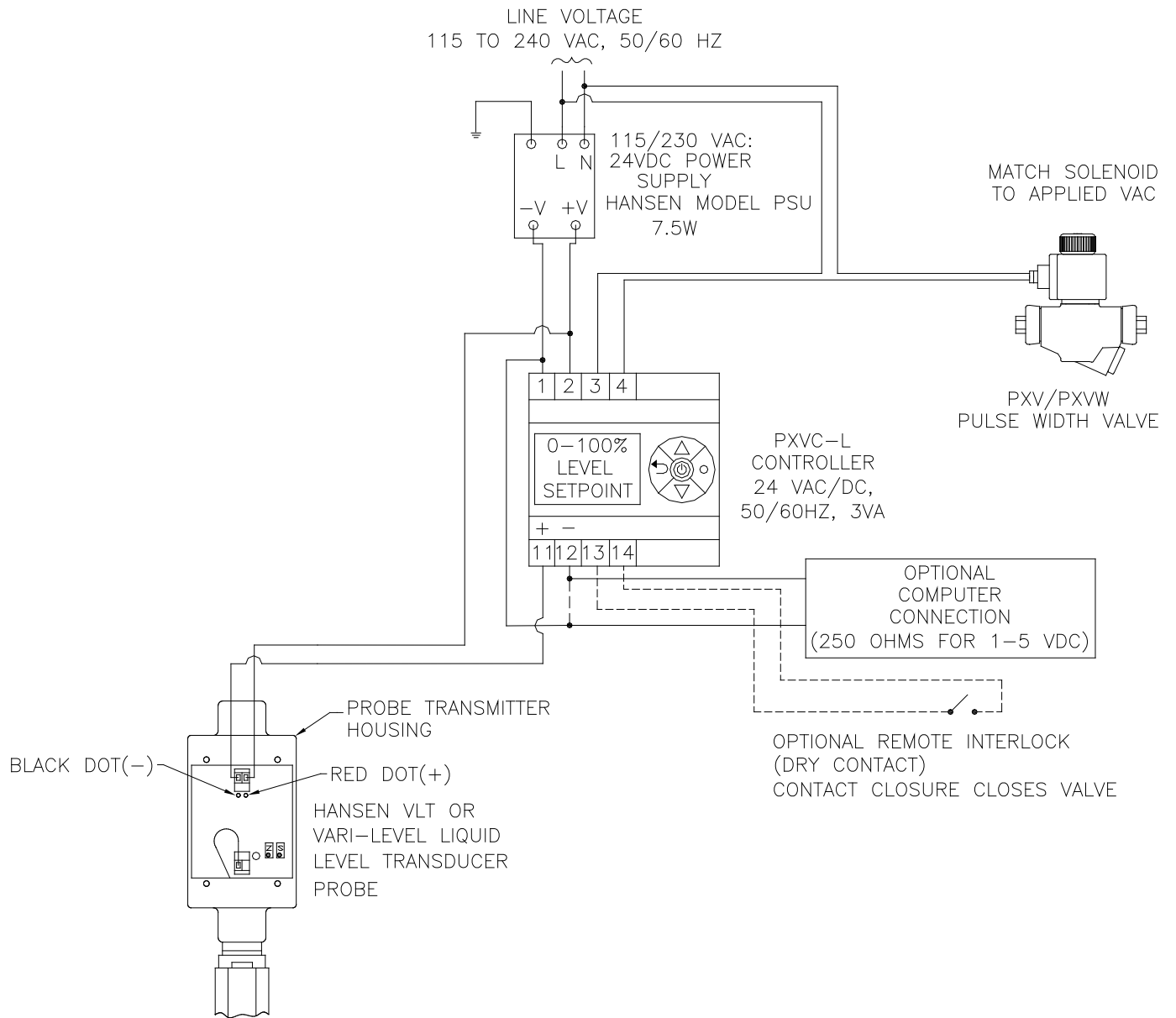

PXV INSTALLATION DIMENSIONS INCHES (MILLIMETERS)

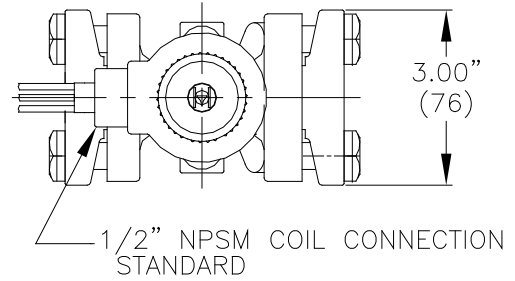
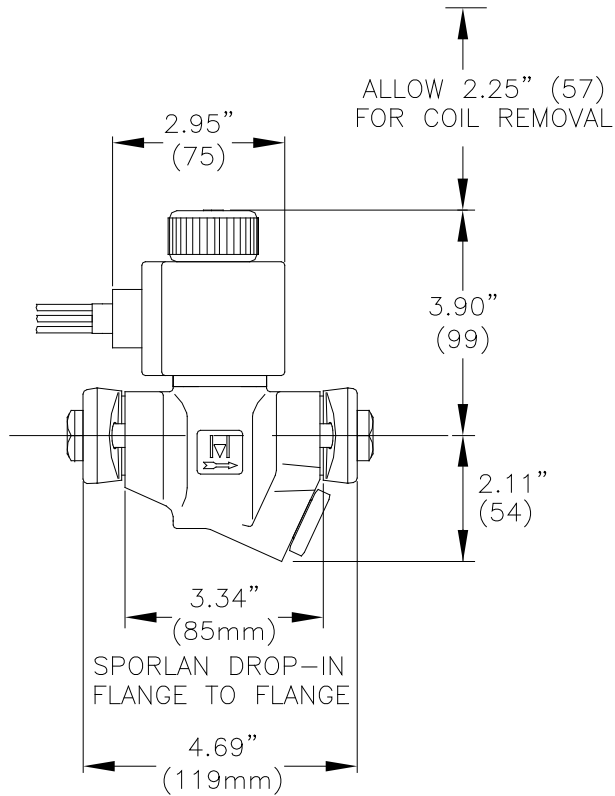

*NOTE: REMOVE EXPANSION ORIFICE PLUG WHEN VALVE IS USED WITH DISTRIBUTOR.

PXV PARTS LIST

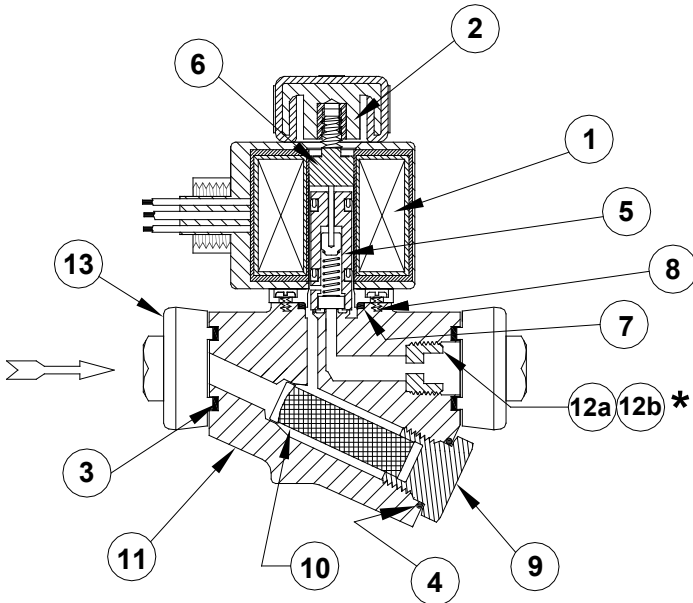

ITEM	DESCRIPTION	QTY	PART NO.
	Coil Kit(115V) 1/2" Fit w/ Leads	1	70-1085
	Coil Kit(208/230V) 1/2" Fit w/ Lds	1	70-1086
	Coil Kit (24V) 1/2" Fit w/ Leads	1	70-1087
	Coil Kit (Other Voltages)	1	FACTORY
	Above kits consist of:		
1a	Bare Coil, 115V 50/60HZ w/ Leads	1	70-0580
1b	Bare Coil, 208/230V 50/60HZ w/ Lds	1	70-0581
1c	Bare Coil, 24V 50/60HZ w/ Leads	1	70-0582
1d	Other Voltage Coils	1	FACTORY
2	Coil Knob	1	70-0579
	PXV Solenoid Tube/Plunger Kit	1	70-1072
	Above kit consists of:		
5	Long life Plunger	1	70-0467
6	Solenoid Tube	1	70-0298
7	Solenoid Tube O-Ring	1	72-0066
8	Tube Screws	4	70-0297
2	Coil Knob	1	70-0579
	PXV Gasket Kit	1	70-1134
	Above kit consists of:		
7	Solenoid Tube O-Ring	1	72-0066
4	Strainer Cap O-Ring	1	72-0066
3	Flange Gasket	2	20-2390
	Strainer Screen Kit	1	78-1010
	Above kit consists of:		
10	Screen Assembly, 100 mesh	1	78-0072
4	Strainer Cap O-Ring	1	72-0066
9	Strainer Cap	1	72-0065
11	PXV Body	1	FACTORY
12a	Expansion Orifice Plug, 5 Ton(3/64")	1	70-0745
12b	Expansion Orifice Plug, 15 Ton (5/64")	1	70-0746
13a	1/2" FPT Flange	2	20-1520
13b	1/2" SW Flange	2	30-0164

PXVW INSTALLATION DIMENSIONS INCHES (MILLIMETERS)

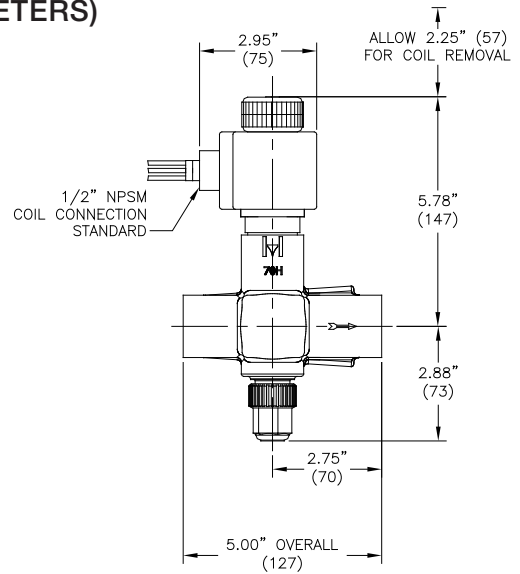
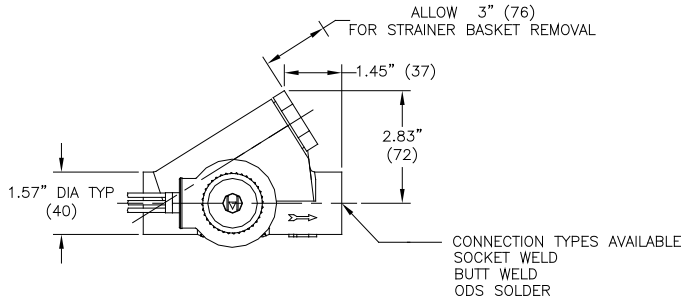

PXVW PARTS LIST

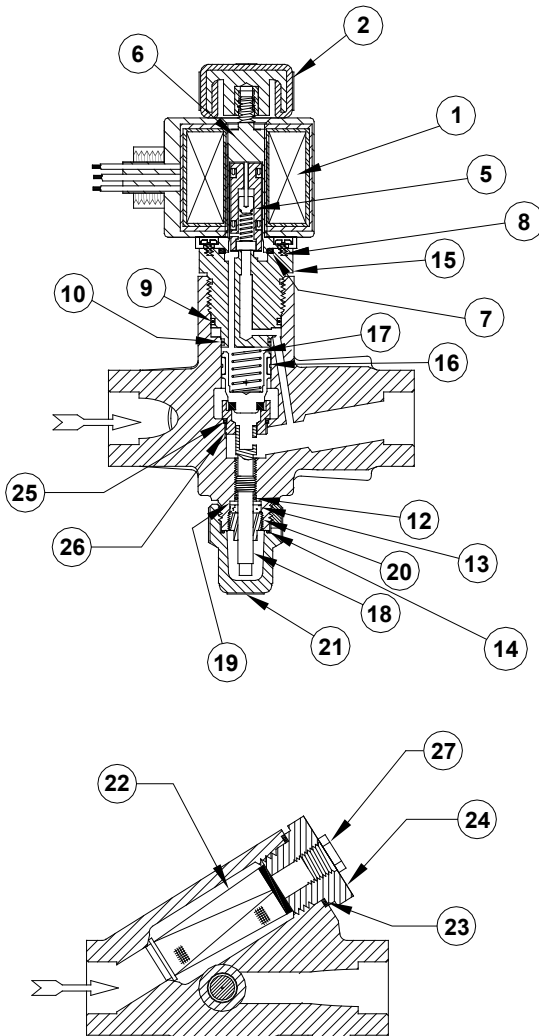

ITEM	DESCRIPTION	QTY	PART NO.
	Coil Kit(115V) 1/2" Fit w/ Leads	1	70-1085
	Coil Kit(208/230V) 1/2"Fit w/ Lds	1	70-1086
	Coil Kit (24V) 1/2" Fit w/ Leads	1	70-1087
	Coil Kit (Other Voltages)	1	FACTORY
	Above kits consist of:		
1a	Bare Coil, 115V 50/60HZ w/ Leads	1	70-0580
1b	Bare Coil, 208/230V 50/60HZ w/ Lds	1	70-0581
1c	Bare Coil, 24V 50/60HZ w/ Leads	1	70-0582
1d	Other Voltage Coils	1	FACTORY
2	Coil Knob	1	70-0579
	PXVW Solenoid Tube/Plunger Kit	1	70-1072
	Above kit consists of:		
5	Long-life Plunger	1	70-0467
6	Solenoid Tube	1	70-0298
7	Solenoid Tube O-Ring	1	72-0066
8	Tube Screws	4	70-0297
2	Coil Knob	1	70-0579
	PXVW Gasket Kit		70-1125
	Above kit consists of:		
7	Solenoid Tube O-Ring	1	72-0066
9	Upper Body O-Ring	1	70-0009
10	Lower Body O-Ring	1	70-0011
12	Stem O-Ring	1	70-0010
13	Packing	1	70-0025
14	Seal Cap O-Ring	1	70-0011
19	Packing Washer	1	70-0026
20	Packing Nut	1	70-0499
25	Seat O-Ring	1	70-0675
	PXVW Stem Kit	1	70-1128
	Above kit consists of:		
18	Capacity Adjustment Stem	1	70-0735
	Gasket Kit	1	70-1125
	Bonnet Cartridge Kit	1	70-1133
	Above kit consists of:		
15	Cartridge Assembly, PXVW	1	70-0703
	Piston/Seat Kit	1	70-1129
	Above kit consists of:		
16	Piston Assembly	1	70-0748
17	Closing Spring	1	70-0494
	Gasket Kit	1	70-1125
26	Beaded Seat	1	70-0739
15	Cartridge Assembly	1	70-0703
	Seat Removal Tool	1	70-0721
	Seal Cap Kit		70-1075
	Above kit consists of:		
21	Seal Cap	1	75-0798
14	Seal Cap O-Ring	1	70-0011
	Strainer Screen Kit	1	78-1001
	Above kit consists of:		
22	Screen Assembly, 100 mesh	1	78-0005
23	Strainer Cap Gasket	1	78-0016
	Strainer Cap Kit	1	78-1022
	Above kit consists of:		
24	Strainer Cap	1	78-0168
23	Strainer Cap Gasket	1	78-0016
27	Plug	1	75-0189

CAUTION

Hansen valves are only for refrigeration systems. These instructions must be completely read and understood before selecting, using or servicing Hansen valves. Only knowledgeable, trained refrigeration mechanics should install, operate, or service these valves. Stated temperature and pressure limits should not be exceeded. Bonnets, solenoid tubes, etc. should not be removed from valves unless system has been evacuated to zero pressure. You must also see Safety Precautions in the current List Price Bulletin and Safety Precautions Sheet supplied with the product. Escaping refrigerant might cause personal injury, particularly to the eyes and lungs.

WARRANTY

All Hansen products, except electronics, are guaranteed against defective materials or workmanship for one year F.O.B. factory. Electronics are guaranteed against defective materials or workmanship for 90 days F.O.B. factory. No consequential damages or field labor is included.

PXVW VALVE SEAT

Before opening the valve for service, be sure it is isolated from the system and all refrigerant is removed. Carefully read and understand the safety precautions.

If you have additional questions or concerns please feel free to contact us.

1. Disconnect electrical power from the coil.
2. Always be careful when loosening the bonnet assembly to be sure no residual pressure exists.
3. Remove the bonnet slowly by unscrewing counterclockwise.
4. Once bonnet has been removed, proceed and remove the spring and then piston.
5. Next use the Seat Removal Tool to extract the seat. (Included with Piston/Seat kit # 70-1129)
6. Using an extension bar size ¼" x 6" long with a drive ratchet, attach the seat removal tool with the two lugs on the end.
7. Remove seat by turning counterclockwise.
8. Once the seat is loose, withdraw the tool.
9. Reverse the seat removal tool and use the o-ring end.
10. Press the tool with the o-ring end into the seat to pull out the seat.

Inspect Parts

1. Look for dirt and debris
2. Look for cuts or cracks on seat o-ring
3. Inspect capacity stem for erosion
4. Clean, repair, and replace parts (if necessary)

Reassembly Instructions

1. Reinstall or replace parts as necessary
2. Gasket kit # 70-1125
3. Bonnet Cartridge kit #70-0703
4. Piston/Seat kit #70-1129
5. Lightly lubricate new O-rings
6. Tighten seat ring using 8ft-lbs torque and reassemble bonnet cartridge using 75ft-lbs torque

ORDERING INFORMATION

CAT NO	CONNECTION STYLE & SIZES			
	FPT, SW, WN		ODS	
	STD	ALSO	STD	ALSO
PXV5	½" FPT	½" SW	–	–
PXV15	½" FPT	½" SW	–	–
PXVW60	½" SW	¾" SW, ½", ¾", 1" BW	1-1/8" ODS	5/8", 7/8" ODS

OPTIONAL BEACON PILOT LIGHTS

CATALOG NUMBER	DESCRIPTION
70-1100	Red Pilot Light Kit
70-1101	Amber Pilot Light Kit
70-1103	Green Pilot Light Kit

TO ORDER: Specify type, connection style and size: ½" SW standard, FPT or WN available. Unless otherwise specified standard coil with ½" fitting for conduit will be supplied with pilot valve. Voltages available include 24V, 120V, and 240VAC. Also available, DIN plug coil for grounded cord connection.



CONTROLLERS

CATALOG NUMBER	APPLICATION
PXVC-DX	DX Control – 4-20 mA Input
PXVC-PT	DX Control – Temp/Pressure Input
PXVC-L	Level Control – 4-20 mA Input
PXVC-T	Temp. Control – NTC 10k Input

Contact factory for Controller details.

H HANSEN

Hansen Technologies Corporation
400 Quadrangle Drive, Suite F
Bolingbrook, Illinois 60440 USA
Tel: 630.325.1565 Fax: 630.325.1572 Toll: 866.4HANSEN
Email: sales@hantech.com Web: www.hantech.com
USA • Asia • Europe • India • Latin America • Middle East