



GS200H Socket Weld Shut-Off Valve

Specifications, Applications, Service Instructions & Parts

SOCKET WELD SHUT-OFF VALVES

**1/2" through 2-1/2"
(13 mm through 65 mm)
Globe & Angle
for Refrigerants**



INTRODUCTION

These low pressure drop refrigerant shut-off valves are designed to be socket-welded directly to steel piping, thereby eliminating potential leaky flanges or threaded joints and simplifying installation. Forged and cast steel bodies are lightweight, yet have substantial wall thickness to help overcome corrosion loss. The cast steel body is rigid, reducing the potential for seat leakage due to flexing of the valve body under abnormal conditions. The “heart” of Hansen shut-off valves is the patented non-leak seal plus packing design. This seal design is used exclusively on Hansen shut-off valves and virtually eliminates stem seal leakage.

APPLICATIONS

Typical uses include:

Ammonia refrigeration system suction, liquid, discharge, recirculating liquid, hot gas, thermosyphon, and oil lines, using handwheel or seal cap models.

Steel pipe portions of halocarbon, commercial, industrial, and air conditioning systems, using seal cap models.

Valves are also available for other fluids such as propane, propylene, and glycol with compatible seals. Contact factory with specific fluid and application details for written approval.

The low friction, non-leak stem seal design permits the use of chain actuation for crossover applications without the need to retighten the packing.

KEY FEATURES

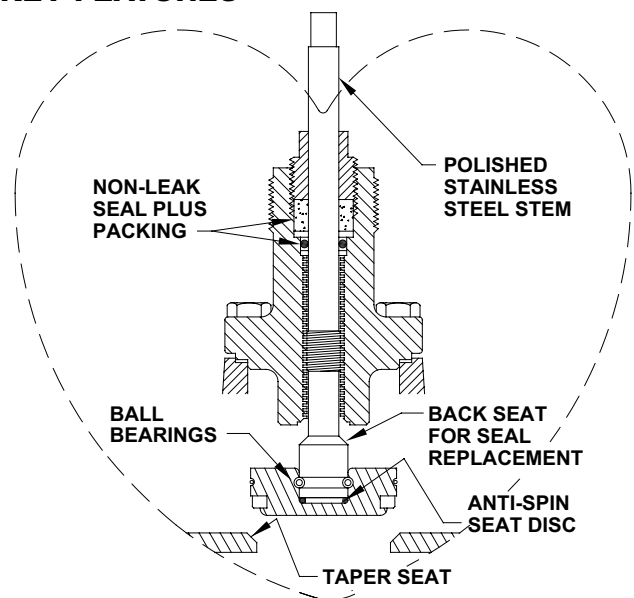

ADDITIONAL FEATURES

Globe and angle valves available.

Low pressure drop design.

Interchangeable handwheel or seal cap.

Teflon seat disc.

Also available as Hand Expansion Valve (see Bulletin G510).

Chain actuators available 1½"-2½" (40mm-65mm).

Suitable for R717 (ammonia), R22, R134a, R507, R404a, R744 (CO₂) and other Hansen approved refrigerants.

Valves for 600 psig (41 bar g) SWP available.

Extended neck available for additional insulation clearance.

MATERIAL SPECIFICATIONS

Body: ½" to 1¼" (13mm to 32mm), forged steel, ASTM A105; 1½" to 2½" (40mm to 65mm), cast steel, ASTM A-352, Grade LCB

Bonnet: Ductile iron, ½" to 2½" (13mm to 65mm), ASTM A-536

Stem: Polished stainless steel

Disc Holder: Plated steel

Seat Disc: Retained PTFE Teflon

Ball Bearings: Stainless steel

Packing Nut: Zinc plated steel

Stem Packing: Graphite composite plus neoprene O-ring in series

Handwheel: ½" to 1¼" (13mm to 32mm), Zinc plated alloy; 1½" to 2½" (40mm to 65mm), Zinc plated iron alloy

Seal Cap: ½" to 1¼" (13mm to 32mm), Glass-filled polymer, safety vented; 1½" to 2½" (40mm to 65mm), Zinc plated steel

Operating Temperature:

Standard, -60°F to 240°F (-51°C to 115°C), temperatures below -60°F (-51°C) to -76°F (-60°C) at coincident pressures

Optional, -20°F to 300°F (-29°C to 149°C) contact factory

Safe Working Pressure: 400 psig (28 bar g) standard, 600 psig (41 bar g) upon request

Connection Dimensions: ½" to 1½" Match Schedule 80 pipe, 2" to 2½" Match Schedule 40 pipe

ADVANTAGES

Compared to conventional stem seal designs, Hansen's patented non-leak seal plus stem packing virtually eliminates stem seal leakage. In addition, the stem is polished to avoid packing wear. The precision stem threads avoid stem wobble and the packing nut is close fitting to remove dirt particles and frost from the stem. This results in infrequent maintenance or tightening and almost no refrigerant loss.

Hansen valves are designed with anti-spin seat discs. High velocity gas can sometimes cause ordinary seat discs to fail over time. Hansen adds a snubber to prevent the seat disc from freely rotating when valve is in the open position.

Compared to threaded valves, Hansen welding valves eliminate the chance of future leaks at pipe threads. In addition, a socket weld pipe-to-valve body joint eliminates the inherent weakness and corrosion vulnerability of the threaded portion of pipe immediately adjacent to a screwed valve body or flange.

Compared to ball valves, Hansen welding valves have no threaded or flanged-gasket pipe joints. Hansen valves also will not open or close so rapidly as to cause severe pipe shock due to sudden change in liquid velocity. In addition, ball valve stem packing typically cannot be replaced while the valve is in a pressurized line. The stem packing on these Hansen valves can be replaced while the valve is in a pressurized line. Also, dirt or damage to ball valve Teflon seats cannot be overcome by greater stem closing forces, an advantage of Hansen valves.

INSTALLATION

All Hansen weld valves can be installed in horizontal or vertical pipe lines. Stems are normally installed horizontally, but, depending on the application, stems may be installed vertically. Inlet pressure or direction of flow for all valve sizes should normally be under valve seat disc. However, to avoid installing an angle valve with the stem down, it is better to install the valve with the normal flow opposite the direction of the arrow.

Care must be taken when handling and installing large valves. Proper lifting devices and safety precautions must be observed.

A valve may have its bonnet assembly removed before welding. The valve stem should be several turns open when removing and replacing the bonnet assembly. The Teflon seat disc should be protected when outside of the valve. Do not allow the Teflon seat to bump the valve body when removing it or stand the bonnet on the seat disc. Where it is necessary or standard practice to weld a valve into the line without bonnet removal, the stem should be opened several turns to prevent heat damage to the seat disc.

Welds should be annealed as necessary in accordance with good practice. Painting of valves and welds is recommended for corrosion protection. Pipe covering, where applied, should have a proper moisture barrier.

Before putting valves into service, all pipe weld connections, valve seats, bonnet seals, and stem seals should be tested for leaks at pressure levels called for in appropriate codes.

Shut-off valves leading to the atmosphere must not be left unsupervised and must be plugged or capped to prevent corrosion inside the valve as well as leakage due to seat expansion, vibration, pressure shock, or improper opening. Where hand wheel valves are subject to excessive vibration or liquid shock loads, the packing nut should be tightened to prevent handwheel vibration from potentially rotating valve stem. The valve seat should be cracked open to prevent hydrostatic expansion between the valve and the cap. A bleed valve and gauge should be installed to provide a means of monitoring and pump-out. Valves should never directly feed a water tank because of potential internal corrosion or seat opening caused by vibration.

INSULATION

Conventional valve-shaped block insulation can occasionally be used for both angle and globe valves. However, fabricated insulation shapes are recommended. If not available locally, Hansen can recommend a source of high quality, economical valve insulation. For exterior valve insulation dimensions, refer to Sales Drawing 5002-28.

EXTENDED NECK VALVES

Hansen bonnets with extended necks, ½" thru 2½" (13mm–65mm), meet or exceed the recommended low temperature insulation thickness dimensions of the IAR Piping Handbook. In addition, the stem and packing nut trim are upgraded to 316 for stainless steel materials. Stainless steel trim is recommended for environments where severe corrosive conditions exist. (Add an "E" suffix to the model number, for example ASE200C or GSE150H.)

SIZING GUIDE

These flow capacity recommendations are not affected by the length of the pipe line. These are approximate optimum sizes based on power costs versus the investment costs of piping and its total installed cost. Piping sized to this capacity will have a 1°F (0.6°C) pressure drop for the following equivalent lengths:

suction lines 700 diameters

discharge lines 1400 diameters

liquid lines 2400 diameters

Example: Hansen valves have about 145 diameters of equivalent flow resistance, or 145/700 = 0.2°F (0.12°C) of equivalent pressure drop at the suction line capacities shown for a valve in a suction line.

The rationale for the vapor line sizing was developed by William V. Richards in two papers: "Refrigerant Vapor Line Sizing Not Dependent of Length," 16th International Congress of Refrigeration, IIR, Paris, 1983; and "Practical Pipe Sizing for Refrigerant Vapor Lines," Sixth Annual Meetings, IAR, San Francisco, 1984.

FLOW COEFFICIENTS

NOMINAL SIZE		ANGLE				GLOBE			
INCH	MM	FLOW COEFFICIENT		EQUIVALENT LENGTH		FLOW COEFFICIENT		EQUIVALENT LENGTH	
		Cv	Kv	FEET	METERS	Cv	Kv	FEET	METERS
1/2"	13	6.0	5.2	3.7	1.1	4.0	3.5	8.4	2.6
3/4"	20	9.0	7.8	8.4	2.6	8.0	6.9	11	3.2
1"	25	19	16	7.2	2.2	15	13	12	3.5
1¼"	32	21	18	27	8.2	16	14	46	14
1½"	40	53	46	10	3.0	41	35	16	5.0
2"	50	80	69	23	7.0	67	58	33	10
2½"	65	173	150	13	3.8	163	141	14	4.3

FLOW CAPACITIES PIPING AND VALVE SIZING GUIDE FOR AMMONIA

SERVICE	CONDITIONS		CAPACITIES (MM)							
	TEMPERATURE °F (°C)	PRESSURE PSIG (BAR)	1/2" (13) TONS (kW)	3/4" (20) TONS (kW)	1" (25) TONS (kW)	1¼" (32) TONS (kW)	1½" (40) TONS (kW)	2" (50) TONS (kW)	2½" (65) TONS (kW)	
Suction Lines Single Stage Compressor	+20 (-6.7)	33.5 (2.3)	- -	- -	8.6 (30)	15.8 (56)	21.3 (75.0)	35.7 (126)	51.1 (180)	
	0 (-17.8)	15.7 (1.1)	- -	- -	5.7 (20)	10.4 (37)	13.9 (49.0)	22.7 (80.0)	34.0 (120)	
Suction Lines Booster	-20 (-28.9)	3.6 (0.25)	- -	- -	4.2 (15)	7.4 (26)	10.3 (36.0)	16.8 (59.0)	24.8 (87.0)	
	-40 (-40)	8.7" (0.7)	- -	- -	- -	4.4 (15)	6.3 (22.0)	9.9 (35.0)	14.4 (51.0)	
Liquid Overfeed Return Lines (4X)	+20 (-6.7)	33.5 (2.3)	- -	- -	5.0 (18)	9.1 (32)	12.3 (43.0)	20.6 (72.4)	29.4 (103)	
	0 (-17.8)	15.7 (1.1)	- -	- -	3.4 (12)	6.3 (22)	8.5 (30.0)	13.6 (48.0)	20.5 (72.0)	
	-20 (-28.9)	3.6 (0.25)	- -	- -	2.2 (8.0)	4.0 (14)	5.5 (19.0)	8.9 (31.3)	13.1 (46.0)	
	-40 (-40)	8.7" (0.7)	- -	- -	- -	2.4 (8.0)	3.4 (12.0)	5.4 (19.0)	7.90 (28.0)	
Hot Gas Feed Hot Gas Main	+70 (+21.1)	114 (7.9)	2.2 (8)	4.3 (15)	7.3 (26)	14.1 (50)	19.6 (69.0)	36.5 (128)	53.0 (186)	
	+70 (+21.1)	114 (7.9)	4.4 (15)	8.6 (30)	14.7 (52)	28.1 (99)	39.2 (138)	73.0 (257)	106 (373)	
Compressor Discharge	+86 (+30)	155 (10.7)	- -	- -	12.6 (44)	24.1 (85)	33.6 (118)	62.6 (220)	90.3 (318)	
Condenser Drains	+86 (+30)	- -	6.0 (21)	14.5 (51)	24.0 (84)	50.0 (176)	77.0 (271)	140 (492)	220 (774)	
Liquid Mains	+86 (+30)	- -	28.3 (100)	53.1 (187)	90.8 (320)	143 (503)	202 (711)	454 (1597)	657 (2311)	
Liquid Feed Branch	+86 (+30)	- -	54.9 (193)	103 (363)	176 (620)	277 (975)	392 (1380)	881 (3098)	1273 (4477)	
Liquid Overfeed Supply (4X)	+10 (-12.2)	- -	9.0 (32)	17.0 (60)	29.0 (102)	46.0 (162)	65.0 (229)	144 (506)	208 (732)	

INSTALLATION DIMENSIONS

1/2" THROUGH 2 1/2" (13MM THROUGH 65MM)

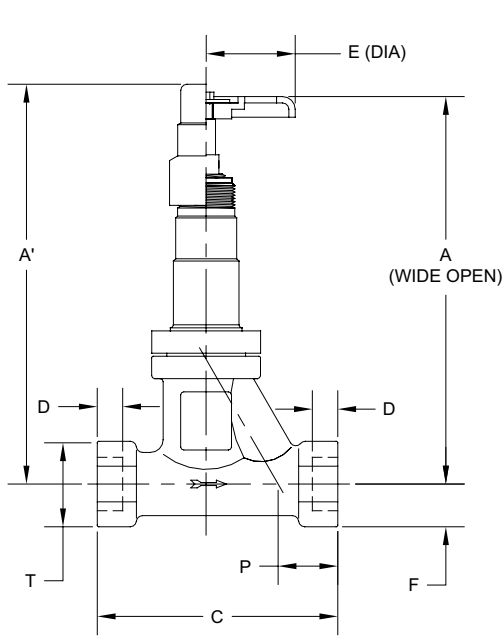

GLOBE

1/2" THROUGH 1 1/4" (13MM - 32MM)

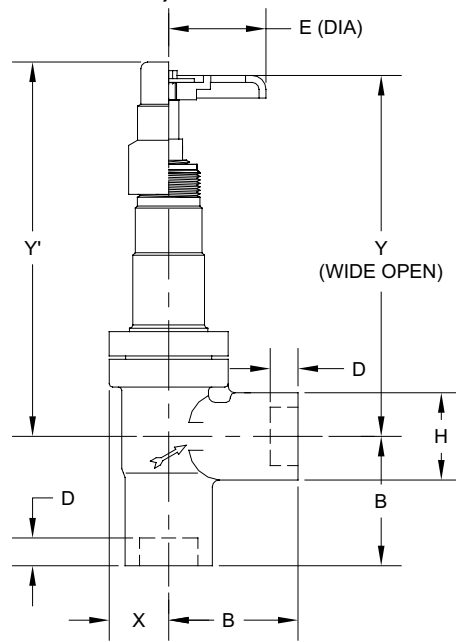

ANGLE

1/2" THROUGH 1 1/4" (13MM - 32MM)

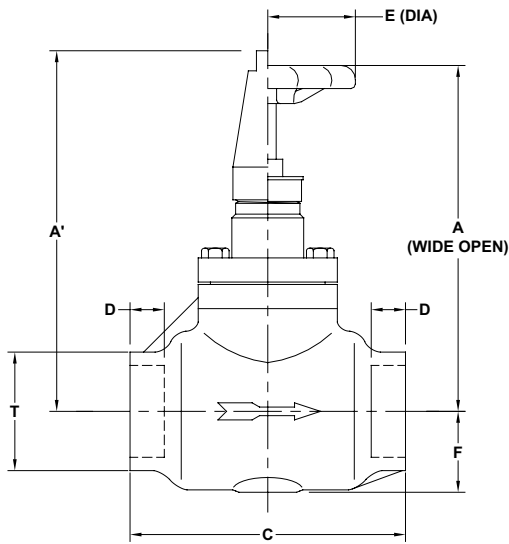

GLOBE

1 1/2" THROUGH 2 1/2" (40MM - 65MM)

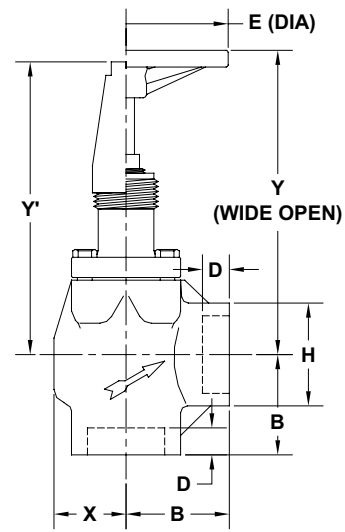

ANGLE

1 1/2" THROUGH 2 1/2" (40MM - 65MM)

SIZE (mm)	GLOBE					ANGLE					D	E	ADD TO A, A', Y, Y' EXT NECK
	A	A'	C	T	F	Y	Y'	B	H	X			
1/2" (13)	7.62" (194)	7.86" (200)	4.73" (120)	1.68" (43)	0.84" (21)	6.46" (164)	6.70" (170)	2.33" (59)	1.57" (40)	1.07" (27)	0.50" (13)	3.50" (89)	1.8" (45)
3/4" (20)	7.62" (194)	7.86" (200)	4.73" (120)	1.68" (43)	0.84" (21)	6.46" (164)	6.70" (170)	2.33" (59)	1.57" (40)	1.07" (27)	0.50" (13)	3.50" (89)	1.8" (45)
1" (25)	7.88" (200)	8.09" (206)	5.93" (150)	2.31" (58)	1.15" (29)	6.24" (158)	6.52" (166)	2.75" (75)	2.31" (59)	1.22" (31)	0.50" (13)	3.50" (89)	1.8" (45)
1 1/4" (32)	7.88" (200)	8.09" (206)	5.93" (150)	2.31" (58)	1.15" (29)	6.24" (158)	6.52" (166)	2.75" (75)	2.31" (59)	1.22" (31)	0.62" (16)	3.50" (89)	1.8" (45)
1 1/2" (40)	8.88" (225)	9.13" (232)	7.25" (184)	3.00" (76)	2.12" (54)	7.75" (197)	8.00" (203)	3.50" (89)	3.00" (76)	1.88" (48)	0.62" (16)	4.25" (108)	2.85" (72)
2" (50)	8.88" (225)	9.13" (232)	7.25" (184)	3.00" (76)	2.12" (54)	7.75" (197)	8.00" (203)	3.50" (89)	3.00" (76)	1.88" (48)	0.88" (22)	4.25" (108)	2.85" (72)
2 1/2" (65)	12.13" (308)	11.75" (298)	9.25" (235)	3.75" (95)	2.75" (70)	11.00" (280)	10.63" (270)	3.50" (89)	3.00" (76)	2.38" (60)	1.00" (25)	7.63" (194)	2.88" (73)

REPLACEMENT PARTS – SOCKET WELD SHUT-OFF VALVES

1/2" THROUGH 1 1/4" (13MM THROUGH 32MM)

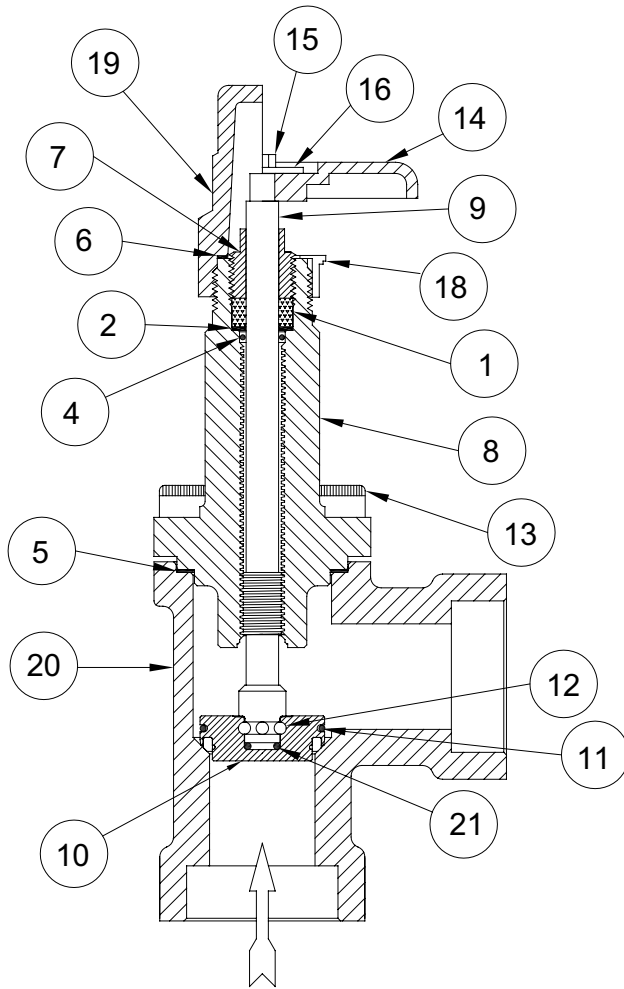

NOTE: Angle valve shown; kits are the same for globe valves.

ITEM	DESCRIPTION	QTY	PART NO
	Gasket Kit 1/2", 3/4", 1", 1-1/4" (13mm, 20mm, 25mm, 32mm)		50-1040
	Gasket Kit, Extended Neck 1/2", 3/4", 1", 1-1/4" (13mm, 20mm, 25mm, 32mm)		50-1171
	<i>Above kits consist of:</i>		
1	Stem Packing	1	50-0045
2	Stem Washer	1	50-0046
4	Stem O-Ring	1	50-0179
5a	Bonnet Gasket 1/2", 3/4" (13mm, 20mm)	1	50-0805
5b	Bonnet Gasket 1", 1-1/4" (25mm, 32mm)	1	50-0806
6	Seal Cap O-Ring	1	50-0432
7a	Packing Nut	1	50-0933
7b	Packing Nut, Extended Neck	1	50-2483
21	O-Ring, Anti-Spin	1	50-2697
* 1	Bonnet Assembly Kit 1/2", 3/4" (13mm, 20mm)		50-1094
	Bonnet Assembly Ext Neck Kit 1/2", 3/4" (13mm, 20mm)		50-1172
* 1	Bonnet Assembly Kit 1", 1-1/4" (25mm, 32mm)		50-1095
	Bonnet Assembly Ext Neck Kit 1", 1-1/4" (25mm, 32mm)		50-1174
	<i>Above kits consist of:</i>		
8a	Bonnet 1/2", 3/4" (13mm, 20mm)	1	50-0743
8b	Bonnet 1", 1-1/4" (25mm, 32mm)	1	50-0774
8c	Bonnet, Ext Neck 1/2", 3/4" (13mm, 20mm)	1	50-2636
8d	Bonnet, Ext Neck 1", 1-1/4" (25mm, 32mm)	1	50-2637
9a	Stem	1	50-0765
9b	Stem, Extended Neck	1	50-2478
10a	Disc Assembly 1/2", 3/4" (13mm, 20mm)	1	50-0803
10b	Disc Assembly 1", 1-1/4" (25mm, 32mm)	1	50-0804
11a	Ball Retainer 1/2", 3/4" (13mm, 20mm)	1	50-0439
11b	Ball Retainer 1", 1-1/4" (25mm, 32mm)	1	50-0026
12	Balls	10	50-0016
13	Bonnet Cap Screws	4	50-0813
	Gasket Kit 1/2" to 1-1/4" (13mm to 32mm)	1	50-1040
	Gasket Kit, Ext Neck 1/2" to 1-1/4"	1	50-1171
	(13mm to 32mm)		
	Disc Assembly Kit 1/2", 3/4" (13mm, 20mm)		50-1042
	Disc Assembly Kit 1", 1-1/4" (25mm, 32mm)		50-1004
	<i>Above kits consist of:</i>		
5a	Bonnet Gasket 1/2", 3/4" (13mm, 20mm)	1	50-0805
5b	Bonnet Gasket 1", 1-1/4" (25mm, 32mm)	1	50-0806
10a	Disc Assembly 1/2", 3/4" (13mm, 20mm)	1	50-0803
10b	Disc Assembly 1", 1-1/4" (25mm, 32mm)	1	50-0804
11a	Ball Retainer 1/2", 3/4" (13mm, 20mm)	1	50-0439
11b	Ball Retainer 1", 1-1/4" (25mm, 32mm)	1	50-0026
12	Balls	10	50-0016
21	O-Ring, Anti-Spin	1	50-2697
	Handwheel Kit		50-1005
	<i>Above kits consist of:</i>		
14	Handwheel	1	50-2691
15	Screw	1	50-0479
16	Nameplate	1	50-0094
18	Bonnet Thread Cap	1	50-0434
	Seal Cap Kit		50-1036
	<i>Above kits consist of:</i>		
6	Seal Cap O-Ring	1	50-0432
19	Seal Cap	1	50-0423
20a	Body, Globe 1/2" SW (13mm)	1	50-2338
20b	Body, Globe 3/4" SW (20mm)	1	50-2341
20c	Body, Globe 1" SW (25mm)	1	50-2343
20d	Body, Globe 1-1/4" SW (32mm)	1	50-2345
20e	Body, Angle 1/2" SW (13mm)	1	50-0767
20f	Body, Angle 3/4" SW (20mm)	1	50-0770
20g	Body, Angle 1" SW (25mm)	1	50-0778
20h	Body, Angle 1-1/4" SW (32mm)	1	50-0781

Note: A plate steel cap is available. To order specify part number 50-1064.

REPLACEMENT PARTS – SOCKET WELD SHUT-OFF VALVES

1½" THROUGH 2½" (40MM THROUGH 65MM)

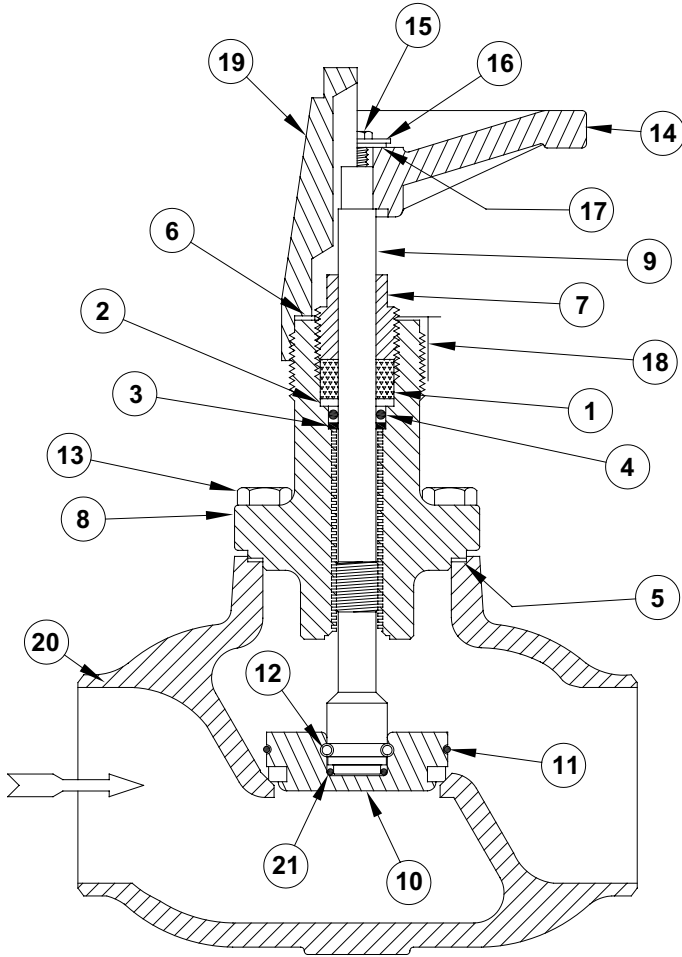

NOTE: Globe valve shown; kits are the same for angle valves.

ITEM	DESCRIPTION	QTY	PART NO
Gasket Kit 1-1/2", 2" consists of:			
1	Stem Packing	1	50-0248
2	Stem Washer	1	50-0247
3	Back-Up Washer	1	50-0351
4	Stem O-Ring	1	50-0253
5	Bonnet Gasket	1	50-0259
6	Seal Cap Gasket	1	50-0270
7	Packing Nut	1	50-0251
21	O-Ring, Anti-Spin	1	50-0637
Bonnet Assembly Kit 1-1/2", 2"			
<i>Above kits consist of:</i>			
8	Bonnet	1	50-0239
9	Stem	1	50-0242
10	Disc Assembly	1	50-0363
11	Ball Retainer	1	50-0257
12	Balls	16	50-0016
13	Bonnet Cap Screw	4	50-0473
	Gasket Kit	1	50-1023
Disc Assembly Kit 1-1/2", 2" consists of:			
10	Disc Assembly	1	50-0363
11	Ball Retainer	1	50-0257
12	Balls	16	50-0016
5	Bonnet Gasket	1	50-0259
Handwheel Kit 1-1/2", 2" consists of:			
14	Handwheel	1	50-0321
16	Name Plate	1	50-0094
15	Screw	1	50-0254
17	Bonnet Thread Cap	1	50-0263
Seal Cap Kit 1-1/2", 2" consists of:			
19	Seal Cap	1	50-0260
6	Seal Cap Gasket	1	50-0270
20a	Body, Globe 1-1/2" S.W.	1	50-0232
20b	Body, Globe 2" S.W.	1	50-0233
20c	Body, Angle 1-1/2" S.W.	1	50-0268
20d	Body, Angle 2" S.W.	1	50-0269

ITEM	DESCRIPTION	QTY	PART NO
Gasket Kit 2-1/2" consists of:			
1	Stem Packing	1	50-0290
2	Stem Washer	1	50-0299
3	Back-Up Washer	1	50-0324
4	Stem O-Ring	1	50-0293
5	Bonnet Gasket	1	50-0310
6	Seal Cap Gasket	1	50-0315
7	Packing Nut	1	50-0292
21	O-Ring, Anti-Spin	1	50-2700
Bonnet Assembly Kit 2-1/2"			
<i>Above kits consist of:</i>			
8	Bonnet	1	50-0286
9	Stem	1	50-0287
10	Disc Assembly	1	50-0374
11	Ball Retainer	1	50-0297
12	Balls	16	50-0305
13	Bonnet Cap Screw	4	50-0294
	Gasket Kit	1	50-1043
Disc Assembly Kit 2-1/2" consists of:			
10	Disc Assembly	1	50-0374
11	Ball Retainer	1	50-0297
12	Balls	16	50-0305
5	Bonnet Gasket	1	50-0310
Handwheel Kit 2-1/2" consists of:			
14	Handwheel	1	50-0319
16	Name Plate	1	50-0318
15	Screw	1	50-0295
17	Support Washer	1	50-0480
Seal Cap Kit 2-1/2" consists of:			
19	Seal Cap	1	50-0304
6	Seal Cap Gasket	1	50-0315
20a	Body, Globe 2-1/2" S.W.	1	50-0456
20b	Body, Angle 2-1/2" S.W.	1	50-0457

SERVICE AND MAINTENANCE

Hansen steel socket welding shut-off valves require practically no service or maintenance due to the combination of polished stainless steel stems and reliable O-ring stem seals plus graphite composite packing. This almost entirely eliminates stem leakage, the common ailment of shut-off valves.

To help ensure safety, verify the tightness of the packing nut whenever the position (open or closed) is changed on isolation shut-off valves before opening the system. Ensuring that the packing nut is tight helps reduce the possibility that any line or system vibration may cause a slight unseating of a closed valve.

STEM PACKING

When verifying the tightness of the packing nut, use an adjustable wrench. Extrusion of some black graphite packing material along the stem is normal. If the O-ring or the adjustable packing ever needs replacement as evidenced by refrigerant or oil leakage at the stem, open the valve stem firmly to the back-seat position. This separates the O-ring and packing from the system refrigerant. Remove the packing nut carefully and then use a wire hook or a small blade screwdriver to remove the packing and O-ring. Take care not to scratch the stem or bonnet sealing surfaces. Carefully install a backup washer, new lubricated stem O-ring, stem washer, and stem packing. Tighten the packing nut only enough to give the handwheel slight turning friction.

VALVE SEAT

To inspect or replace the valve seat disc, isolate the valve from the system and safely pump out all refrigerant to zero pressure with the stem open at least one turn. Evenly loosen all bolts one to two turns. Using a screwdriver, break the seal between the bonnet and valve body, proceeding cautiously to avoid any refrigerant which may still remain inside the valve body. Remove the bonnet bolts and bonnet assembly, being careful not to damage the Teflon seat disc surface. If the seat surface in the body is marred, it may be possible to repair the seat by polishing with emery paper.

If the Teflon seat disc is damaged, replace the entire disc assembly $\frac{1}{2}$ " (13mm) thru $2\frac{1}{2}$ " (65mm) by first removing the ball retainer spring, ball bearings and anti-spin O-ring. Install a new disc assembly including anti-spin O-ring. Alternately, use a lathe to take a $\frac{1}{64}$ " (0.4 mm) by 45° surface cut on the Teflon seat.

Replace body gasket or O-ring and reassemble bonnet into body using care not to damage Teflon seat surface. Be careful not to pinch the O-ring. If necessary, retain O-ring in O-ring groove by using a suitable O-ring grease. Ensure the stem is opened at least several turns.

Hansen assembles valves with bonnet cap screws factory tightened as follows: $\frac{1}{2}$ " to $1\frac{1}{4}$ " (13mm to 32mm)–30 ft-lb (41 Nm); $1\frac{1}{2}$ " (40mm) and 2" (50mm)–40 ft-lb (54 Nm); and $2\frac{1}{2}$ " (65mm)–60 ft-lb (81 Nm). Test the valve for leaks before returning it to service.

TROUBLESHOOTING VALVE LEAKS

On the rare occasion when a small valve leak is discovered, the following procedures may help:

Stem seal leaks – The possibility of this occurrence is based on many factors, such as frequency of use, exercising, debris or rust on stem, etc. First, simply tighten the packing nut to see if this eliminates the leak. If not, back seat the valve or isolate it entirely from the refrigeration system. See Stem Packing section of this bulletin.

Bonnet gasket leaks – If a gasket leak is discovered at the bonnet-to-body interface, first bring the pressure in the valve to zero pressure and check the bonnet bolt tightness. If the leak persists, isolate the valve from the refrigeration system and disassemble the valve. Check the gasket sealing surfaces on the bonnet and valve body for scratches or gouges. These scratches can sometimes be polished smooth. Install a new gasket and reassemble the valve. Evenly tighten all bolts to properly seat the bonnet. Repeat the pressure test.

ORDERING INFORMATION, SOCKET WELD SHUT-OFF VALVES

SIZE	DESCRIPTION	CAT NO
1/2" (13 mm)	Globe, Handwheel	GSB051H
	Angle, Handwheel	ASB050H
	Globe, Seal Cap	GSB051C
	Angle, Seal Cap	ASB050C
3/4" (20 mm)	Globe, Handwheel	GSB076H
	Angle, Handwheel	ASB075H
	Globe, Seal Cap	GSB076C
	Angle, Seal Cap	ASB075C
1" (25 mm)	Globe, Handwheel	GSB101H
	Angle, Handwheel	ASB100H
	Globe, Seal Cap	GSB101C
	Angle, Seal Cap	ASB100C
1 1/4" (32 mm)	Globe, Handwheel	GSB126H
	Angle, Handwheel	ASB125H
	Globe, Seal Cap	GSB126C
	Angle, Seal Cap	ASB125C
1 1/2" (40 mm)	Globe, Handwheel	GS150H
	Angle Handwheel	AS150H
	Globe, Seal Cap	GS150C
	Angle, Seal Cap	AS150C
2" (50 mm)	Globe, Handwheel	GS200H
	Angle, Handwheel	AS200H
	Globe, Seal Cap	GS200C
	Angle, Seal Cap	AS200C
2 1/2" (65 mm)	Globe, Handwheel	GS251H
	Angle, Handwheel	AS251H
	Globe, Seal Cap	GS251C
	Angle, Seal Cap	AS251C

TO ORDER

Specify catalog number. To order valves with extended neck, add the letter "E" to the catalog number (Example: GSE051H or ASE125C). To order valves for 600 psig (41 bar g) SWP, add the letter "C" prefix to catalog number (Example: CGSB076H or CASB100H). CE marked valves are available, add the letter "E" suffix to catalog number for sizes 1 1/4" (32mm) and larger (Example: AS150HE).

CAUTION

Hansen valves are for refrigeration systems only. These instructions must be completely read and understood before selecting, using, or servicing Hansen valves and electronics. Only knowledgeable, trained refrigeration mechanics should install, operate, or service. Stated temperature and pressure limits should not be exceeded. Bonnets should not be removed from valves unless the system has been evacuated to zero pressure. See also Safety Precautions in the current List Price Schedule and the Safety Precautions Sheet supplied with the product.

WARRANTY

All Hansen products, except electronics, are guaranteed against defective materials or workmanship for one year F.O.B. factory. Electronics are guaranteed against defective materials or workmanship for 90 days F.O.B. factory. No consequential damages or field labor is included.

TYPICAL SPECIFICATIONS

"Weldable refrigerant shut-off valves shall have stainless steel stems with dual seals, forged or cast steel bodies, back-seating design for packing replacement, bonnet threads for installation of stem seal caps, socket weld ends machined dimensionally correct for schedule 80 pipe (sizes 1/2" to 1 1/2") and schedule 40 pipe (sizes 2" to 2 1/2"), and suitable for a safe working pressure of 400 psig (28 bar g) or 600 psig (41 bar g), as manufactured by Hansen Technologies Corporation, or approved equal."

H HANSEN

Hansen Technologies Corporation
400 Quadrangle Drive, Suite F
Bolingbrook, Illinois 60440 USA
Tel: 630.325.1565 Fax: 630.325.1572 Toll: 866.4HANSEN
Email: sales@hantech.com Web: www.hantech.com
USA · Asia · Europe · India · Latin America · Middle East
© 2013 Hansen Technologies Corporation